

2 YEAR
WARRANTY



 **User's Guide**



Shop online at

omega.com
/USA/EN/

omega.com

e-mail: info@omega.com

For latest product manuals:

omegausa.com/info



Made in China

CN4000 Series
Models CN4300/CN4400
Temperature Controller
Programmable Temperature Controller



OMEGAnet® Online Service
www.omega.com

Internet e-mail
info@omega.com

Servicing North America:

USA:
ISO 9001 Certified

One Omega Drive, P.O. Box 4047
Stamford CT 06907-0047
TEL: (203) 359-1660 FAX: (203) 359-7700
e-mail: info@omega.com

Canada:

976 Bergar
Laval (Quebec) H7L 5A1, Canada
TEL: (514) 856-6928 FAX: (514) 856-6886
e-mail: info@omega.ca

For immediate technical or application assistance:

USA and Canada: Sales Service: 1-800-826-6342 / 1-800-TC-OMEGA®
Customer Service: 1-800-622-2378 / 1-800-622-BEST®
Engineering Service: 1-800-872-9436 / 1-800-USA-WHEN®
TELEX: 996404 EASYLINK: 62968934 CABLE: OMEGA

Mexico:

En Español: (001) 203-359-7803 e-mail: espanol@omega.com
FAX: (001) 203-359-7807 info@omega.com.mx

Servicing Europe:

Benelux: Postbus 8034, 1180 LA Amstelveen, The Netherlands
TEL: +31 (0)20 3472121 FAX: +31 (0)20 6434643
Toll Free in Benelux: 0800 0993344
e-mail: sales@omegaeng.nl

Czech Republic: Frystatska 184, 733 01 Karviná, Czech Republic
TEL: +420 (0)59 6311899 FAX: +420 (0)59 6311114
Toll Free: 0800-1-66342 e-mail: info@omegashop.cz

France: 11, rue Jacques Cartier, 78280 Guyancourt, France
TEL: +33 (0)1 61 37 2900 FAX: +33 (0)1 30 57 5427
Toll Free in France: 0800 466 342
e-mail: sales@omega.fr

Germany/Austria: Daimlerstrasse 26, D-75392 Deckenpfronn, Germany
TEL: +49 (0)7056 9398-0 FAX: +49 (0)7056 9398-29
Toll Free in Germany: 0800 639 7678
e-mail: info@omega.de

United Kingdom: One Omega Drive, River Bend Technology Centre
ISO 9002 Certified Northbank, Irlam, Manchester
M44 5BD United Kingdom
TEL: +44 (0)161 777 6611 FAX: +44 (0)161 777 6622
Toll Free in United Kingdom: 0800-488-488
e-mail: sales@omega.co.uk

It is the policy of OMEGA to comply with all worldwide safety and EMC/EMI regulations that apply. OMEGA is constantly pursuing certification of its products to the European New Approach Directives. OMEGA will add the CE mark to every appropriate device upon certification.

The information contained in this document is believed to be correct, but OMEGA Engineering, Inc. accepts no liability for any errors it contains, and reserves the right to alter specifications without notice.
WARNING: These products are not designed for use in, and should not be used for, human applications.

CONTENTS

MODEL CONFIGURATION.....	3
SPECIFICATIONS.....	7
PARAMETER AND SETTING.....	11
FIELD PARAMETER TABLE	13
SYSTEM PARAMETER TABLE.....	15
SYMBOL DESCRIPTIONS.....	33
INSTRUMENT INSTALLATION AND WIRING.....	34
DISPLAYS AND OPERATIONS.....	36
OPERATION DESCRIPTION.....	38
PARAMETER SETTING FLOW CHART.....	46
PROGRAMMING AND OPERATION.....	47

MODEL CONFIGURATION

Model	Description
CN4316(*)-(**)-(***)	1/16 DIN controller, Support 0~5/1~5V Voltage Input
CN434(*)-(**)-(***)	1/4 DIN controller, Support 0~5/1~5V Voltage Input
CN438V(*)-(**)-(***)	1/8 DIN Vertical controller, Support 0~5/1~5V Voltage Input
CN438H(*)-(**)-(***)	1/8 DIN Horizontal controller, Support 0~5/1~5V Voltage Input

Programmable Controller

CN4416(*)-(**)-(***)	1/16 DIN controller, 30 Segment, Support 0~5/1~5V Voltage Input
CN444(*)-(**)-(***)	1/4 DIN controller, 30 Segment, Support 0~5/1~5V Voltage Input
CN448V(*)-(**)-(***)	1/8 DIN Vertical controller, 30 Segment, Support 0~5/1~5V Voltage Input
CN448H(*)-(**)-(***)	1/8 DIN Horizontal controller, 30 Segment, Support 0~5/1~5V Voltage Input

* *Specify controlling output code from Output Options table below*

** *Specify alarm output code from Alarm Options table below*

*** *Low voltage power supply option (-LV)*

Control output options

Option Type	Controlling output code
Relay	-R1
DC SSR driver	-DC1
4~20 mA Linear Current	-F1

Alarm output options

Option Type	Alarm output code
Relay	-R2
DC SSR driver	-DC2

Low voltage power supply option

-LV 24V AC/DC, 50/60 Hz

SPECIFICATIONS

Input Type	Thermocouple							
	K	S	R	E	J	T	B	N
Range	-50 to 1300 °C	-50 to 1700 °C	-50 to 1700 °C	0 to 800 °C	0 to 1000 °C	-200 to 350 °C	200 to 1800 °C	0 to 1300 °C
°C/ °F	-58 to 2372 °F	-58 to 3092 °F	-58 to 3092 °F	32 to 1472 °F	32 to 1832 °F	-328 to 662 °F	392 to 3272 °F	32 to 2372 °F

Input Type	RTD	
	Cu50	PT100
Range °C/ °F	-50 to 150 °C	-200 to 800 °C
	-58 to 302 °F	-328 to 1472 °F

Input Type	Linear Voltage	Linear Current (external resistor needed)
	0 to 5V, 1 to 5V, 0 to 1V, 0 to 20mV, 0 to 100mV	0 to 10mA, 0 to 20mA, 4 to 20mA

Accuracy	0.3%FS \pm 0.1°C/ 0.18 °F
-----------------	-----------------------------

Display Resolution	0.1°C/0.1°F
---------------------------	-------------

Control Method	ON / OFF Control
	AI PID Control with Auto Tuning (AT)
	Standard PID with Auto Tuning (AT)

Output Type	Relay Output (1A/250VAC)
	Voltage Output for SSR (15V/30mA)
	Linear Current (4 to 20 mA)

Alarm	Limit High / Limit Low
	High deviation / Low deviation

Supply Voltage	100~240VAC (-15%, +10%), or 24VDC
	50~60Hz

Power Consumption	$\leq 3W$
--------------------------	-----------

Operating Environments	Temperature: -10~+60°C / 14~140°F
	Humidity: 0~90RH%

Electromagnetic compatibility	IEC61000-4-4: $\pm 4KV/5KHz$, IEC61000-4-5: 4KV
--------------------------------------	--

PARAMETER AND SETTING

Parameter is protected by LOC (Parameter LOCK) to prevent setting error. The function was shown as below:

√ : allow to modify data or execute

X : not allow to modify data or execute

Run, Stop, Hold. and Program Time & Temp. function just for CN 44 only

Loc	SV	AT	Primary Parameter	Secondary Parameter	Status changing to Run, Stop or Hold	Program Step Time & Temp.
0	√	√	√	X	√	√
1	√	X	√	X	X	√
2	X	X	√	X	√	X
3	X	X	√	X	X	X

4~255	X	X	X	X	X	X
808	√	√	√	√	√	√

Loc 808 is the master password, can be changed by parameter PASd.

Please set PASd cautiously, if the password lost, you can't access the parameter table again.

1 to 8 field parameters can be defined by parameters EP1 to EP8. If the number of the field parameters is less than 8, the first idle EP parameter should be set to “nonE”. The initial values of EPs and Loc are EP1=HIAL, EP2=LoAL, EP3=HdAL, EP4=LdAL, EP5=nonE, EP6=nonE, EP7=nonE, EP8=nonE and Loc=0.

You can redefine field parameters and Loc to change operation style. For example, you can execute auto tuning from field parameter instead of by pressing  in basic display status, and only take HIAL and HdAL as field parameter.

The EP paramters and Loc should be set as below:

EP1=HIAL, EP2=HdAL, EP3=At, EP4=nonE, Loc=1

Field parameter table (Primary parameters)

Code	Description	Remarks	Setting Range
HIAL	High limit alarm	Alarm on when $PV > HIAL$ Alarm off when $PV < HIAL - AHYS$, When the value set to Max. will disable this function	-9990~30000
LoAL	Low limit alarm	Alarm on when $PV < LoAL$; Alarm off when $PV > LoAL + AHYS$, When the value set to Min. will disable this function	
HdAL	Deviation high alarm	Alarm on when $PV - SV > HdAL$; Alarm off when $PV - SV < HdAL - AHYS$, When the value set to Max. will disable this function	

LdAL	Deviation low alarm	Alarm on when $PV-SV < LdAL$; Alarm off when $PV-SV > LdAL + AHYS$, When the value set to Min. will disable this function	
-------------	---------------------	---	--

System parameter table (Secondary parameters)

Set the parameter 'Loc'=808 to enter:

*******: Those Parameters just for CN 44 (Programmable Controller) Only

AHYS	Alarm hysteresis	Avoid frequent alarm on-off action because of the fluctuation of PV	0~2000
AdIS	Alarm display	oFF : Will not display alarm message in the lower display window when alarming; on : Alternately display alarm message in the lower display window when alarming.	oFF / on

AOP	Alarm output assignment	<table border="1" style="width: 100%; border-collapse: collapse;"> <tr> <th style="text-align: center;">Alarm Output to</th> <th style="text-align: center;">LdAL (x 1000)</th> <th style="text-align: center;">HdAL (x100)</th> <th style="text-align: center;">LoAL (x10)</th> <th style="text-align: center;">HIAL (x1)</th> </tr> <tr> <td style="text-align: center;">None</td> <td style="text-align: center;">0</td> <td style="text-align: center;">0</td> <td style="text-align: center;">0</td> <td style="text-align: center;">0</td> </tr> <tr> <td style="text-align: center;">AL1</td> <td style="text-align: center;">1</td> <td style="text-align: center;">1</td> <td style="text-align: center;">1</td> <td style="text-align: center;">1</td> </tr> <tr> <td style="text-align: center;">AU1</td> <td style="text-align: center;">3</td> <td style="text-align: center;">3</td> <td style="text-align: center;">3</td> <td style="text-align: center;">3</td> </tr> </table>	Alarm Output to	LdAL (x 1000)	HdAL (x100)	LoAL (x10)	HIAL (x1)	None	0	0	0	0	AL1	1	1	1	1	AU1	3	3	3	3	0~4444
		Alarm Output to	LdAL (x 1000)	HdAL (x100)	LoAL (x10)	HIAL (x1)																	
		None	0	0	0	0																	
		AL1	1	1	1	1																	
		AU1	3	3	3	3																	
<p>eg: AOP=1101 means LdAL, HdAL and HIAL have alarm action from AL1; LoAL, no alarm action.</p> <p>For 1/4 DIN and 1/8 DIN controller, the alarm contact will trigger form AL1. (Terminal No.5 and No.7)</p> <p>For 1/16 DIN controller, the alarm contact will trigger form AU1. (Terminal No.3 and No.5, need set parameter bAud=0)</p>																							

<p>Ctrl</p>	<p>Control mode</p>	<p>onoF : On-off control APId : AI PID control, high precision (Recommend) nPid: Standard PID algorithm with Anti-integral-saturation function (no integral when PV-SV > proportional band); PoP: Transmit PV. The instrument works as a temperature retransmitter. SoP: No function</p>	<p>OnoF / APId, nPID / PoP, SoP</p>
<p>Srun</p>	<p>Running status</p>	<p>run: Control was running, “RUN” led light on StoP: Control was stopped. Lower display keep flashing “StoP” and “RUN” led light off. HoLd: Keeping Temperature. If the parameter Pno=0(Non timing limitation mode), controller keep running and cannot change the running status from</p>	<p>run / StoP / HoLd</p>

		panel, if Pno>0 (in program mode), and Srun was shown HoLd, means the timer stops and the temperature remains; user can resume the time by pressing the “ Hold ” from panel.	
Act	Acting method	<p>rE: Reverse acting. Increase in measured variable causes decrease in the output, such as heating control.</p> <p>dr: Direct acting. Increase in measured variable causes an increase in the output, Such as refrigerating control.</p> <p>rEbA: Reverse acting with low limit alarm and deviation low alarm blocking when the beginning of power on.</p> <p>drbA: Direct acting with high limit alarm and deviation high alarm blocking when the beginning of power on.</p>	rE /dr/ rEbA/dr bA
At	Auto tuning	<p>oFF: Auto tuning function was off.</p> <p>on: Active auto turning function to calculate the values</p>	oFF / On / FoFF

		FoFF : Auto tuning function was off, cannot activate again by pressing key from panel .	
P	Proportion band	Proportion band in PID with unit °C or °F	1~32000
I	Time of Integral	No integral effect when I=0, with unit 1 Sec.	1~9999 Sec
d	Time of derivative	No derivative effect when d=0, with unit 0.1 Sec.	0~3200 Sec
Ctl	Control period	<p>Small value can improve control accuracy. For SSR output, generally 0.5 to 3 seconds.</p> <p>Large value can increase using life of relay. For Relay output, generally 15 to 40 seconds.</p> <p>When parameter Opt =rELY, Ctl will limited more than 3 seconds. Auto tuning will automatically set Ctl to suitable value considering both control precision and mechanical switch longevity.</p>	0.2~300.0 Sec

		When the parameter CtrL = onoF, Ctl will used as timer to make delay time to avoid the power restart in short period. It suit for compressor protection.	
P2	N/A	No any function on this model.	1~32000
I2	N/A	No any function on this model.	1~9999
d2	N/A	No any function on this model.	0~3200
Ctl2	N/A	No any function on this model.	0.2~300.0
CHYS	Control hysteresis	CHYS is used for ON-OFF Control. To avoid too frequent action on relay. In reverse acting (heating) $PV > SV$, output turns off, when $PV < SV - CHYS$, output turns on. In direct acting (cooling), $PV < SV$, output off, when $PV > SV + CHYS$, output on.	0~2000

InP	Input specification		InP	Input spec.	InP	Input spec.	0~37
			0	K	1	S	
			2	R	3	T	
			4	E	5	J	
			6	B	7	N	
			8-16	Spare	17	K (0~300°C)	
			18	J(0~300°C)	20	Cu50	
			21	Pt100	22	Pt100 (-80~300°C)	
			25	0~75mV	26	0~80ohms	
			27	0~400ohms	28	0~20mV	

			29	0~100mV	30	0~60mV			
			31	0~500mV	32	100~500mV			
			33	1~5V	34	0~5V			
			35	0~10V	36	2~10V			
			37	0~20V					
dPt	Display resolution	<p>Four display resolution can selected by setting: 0 / 0.0 / 0.00 / 0.000. For linear voltage input, recommend set to =0.000</p>							

SCL	Signal scale low limit	Define scale low limit of input. It is also the low limit of retransmission output (Ctrl=POP)	-9990~ 32000
SCH	Signal scale high limit	Define scale high limit of input. It is also the high limit of retransmission output.(Ctrl=POP)	
Scb	Input shift	Parameter Scb is used to make input shift to compensate the error produced by sensor or input signal itself. PV-after-compensation= PV-before-compensation + Scb.	-1999~ +4000 Default value=0

FILt	PV input filter	<p>The value of FILt will determine the ability of filtering noise.</p> <p>When a large value is set, the measurement input was stabilized but the response speed will decreased.</p> <p>Generally, if great interference exists, then you can increase parameter “FILt” gradually to make momentary fluctuation of measured value less than 2 to 5.</p> <p>When the meter of the instrument is being examined at laboratory, “FILt” should be set to 0 or 1 to short the response time. Unit of FILT= 0.5Sec.</p>	0~40
-------------	-----------------	--	------

Fru	Selection of power frequency and temperature scale	<p>50C: 50Hz,display °C. , 50F: 50Hz, display °F</p> <p>60C: 60Hz,display °C. , 60F: 60Hz, display °F.</p> <p>Input has max. anti-interference ability to 50Hz or 60Hz frequency when parameter set;</p>	50C, 50F 60C, 60F
Opt	Main output type	<p>SSr: Output SSr drive voltage. The output power can be adjusted by the on-off time proportion. The period (Ctl) is generally 0.5~4 seconds.</p> <p>rELy: For relay contact output or for execution system with mechanical contact switch.</p> <p>To protect the mechanical switch, the output period (Ctl) is limited to 3~120 seconds, generally is 1/5 to 1/10 of derivative time.</p> <p>0-20: 0~20mA linear current output.</p> <p>4-20: 4~20mA linear current output.</p>	SSr rELy 0-20 4-20 PHA

		PHA : No Function.	
Aut	NA	No any function on this model.	SSr / rELy 0-20 / 4-20
OPL	Output low limit	0~100%: OPL is for set minimum output of OUPP in single directional control system.	0~100%
OPH	Output upper limit	OPH limits the maximum of OUPP (main output) when PV<OEF. OPH should be greater than OPL.	0~110%
OEF	Work range of OPH	When PV<OEF, the upper limit of OUPP is OPH; When PV>OEF, the upper limit of OUPP is 100%. This function is for avoid the temperature raises too fast. For example: the heater only can working 30% power when the temperature under 150 degree. We can set : OEF =150.0 (°C), OPH=30(%)	-1999 ~ 3000.0

Addr	N/A	No any function on this model.	0~100
bAud	N/A	No any function on this model.	0
Et	N/A	No any function on this model.	none/ ruSt /SP1.2/ PId2
AF	Advanced function	AF is used to select advanced function. The value of AF is calculated as below: AF=Ax1 + Bx2 + Cx4 + Dx8 + Ex16 + Fx32 + Gx64 A=0 B=0, alarm and control hysteresis work as unilateral hysteresis; B=1, as bilateral hysteresis C=0, D=0, when set Loc=808 can access the whole	0~255

		<p>parameter table;</p> <p>D=1, when set Loc=PASd can access the parameter table.</p> <p>E=0</p> <p>F=0, Fine control mode, internal control resolution was demonstration's 10 times. When on linear input mode, biggest display value is 3200 units</p> <p>F=1, Wide range display mode, when the value is bigger than 3200 ,chooses this option</p> <p>G=0, When the thermocouple or RTD input is burnt out, PV value will increase and trigger the high limit alarm.</p> <p>G=1, When the thermocouple or RTD input is burnt out, PV value will increase and NOT trigger the high limit alarm. After it was sets, High Limit alarm will have 30</p>	
--	--	---	--

		sec. delay for trigger in normal usage. Note: AF=0 is recommended.	
PASd	Custom password	When PASd=0~255 or AF.D=0, set Loc=808 can enter the whole parameter table. When PASd=256~9999 and AF.D=1, only setting Loc=PASd can access the whole parameter table. Please set PASd cautiously, if the password is lost, you can't access the parameter table again.	0~9999
SPL	Low limit of SV	Minimum value that SV is allowed to be	-9990~ 30000
SPH	Upper limit of SV	Maximum value that SV is allowed to be	
SP1	Set point 1	When Pno=0 or 1, SV=SP1	SPL~SPH
SP2	N/A	No any function on this model.	

<p>SPr ***</p>	<p>Ramp slope limit</p>	<p>Once SPr was set, if PV<SV when program start, the first step of ramp slope will limited by SPr value, under this limitation, the RUN lamp will keep flashing. For Ramp mode. SPr had effect on first step only. For Soak mode, SPr had effect on each step.</p>	<p>0~3200°C /Min</p>
<p>Pno ***</p>	<p>No. of program step</p>	<p>To define the number of program in use. Pno= 0, disable the program running mode, can set the parameter “SPr” to limit the ramp time. Pno=1~30, CN44 working as normal programmable controller</p>	<p>0~30</p>

<p>PonP ***</p>	<p>Program run mode after power restart</p>	<p>Cont : Continue to run the program from the original break point. If STOP STATUS was activated before power cut, then it (the program) will keep stop status after power restart.</p> <p>StoP : Stop the program after power restart</p> <p>run1 : Start to run the program from step 1 unless the instrument was in “stop” state before power cut.</p> <p>dASt : If these have deviation alarm after power resume, then stop the program, otherwise, continue run the program from the original break point.</p> <p>HoLd : Go into HOLD state after power on. If it is in StoP state before power cut, then keep in StoP State after power on.</p>	<p>Cont / StoP / run1 / dASt / HoLd</p>
----------------------------	---	---	---

<p>PAF ***</p>	<p>Program Running mode</p>	<p>PAF = Ax1 + Bx2 + Cx4 + Dx8 When A=0, Enable ready (rdy) function A=1, Disenable ready (rdy) function B=0, Ramp mode. B=1, Soak mode C=0, Time unit in Minute, the range is 0.1~3200. C=1, Time unit in Hour, the range is 0.1~3200 D=0, Disable PV start up function. D=1, Enable PV start up function.</p>	
<p>EP1~ EP8</p>	<p>Field parameter definition</p>	<p>Define 0~8 of the parameters as field parameters.</p>	

SYMBOL DESCRIPTIONS

Symbol	Description
orAL	Input specification setting is incorrect Or Input wiring is disconnected/ thermocouple problem Or Short circuited
HIAL	High limit alarm
LoAL	Low limit alarm
HdAL	Deviation high alarm
LdAL	Deviation low alarm
EErr	IC Software error
8888	IC Software error

INSTRUMENT INSTALLATION AND WIRING

Wiring graph for instruments with dimension 1/4 DIN; 1/8 DIN Vertical and Horizontal

Note 1: The compensation wires for different kinds of thermocouple are different, and should be directly connect to the terminals. Connecting the common wire between the compensation wire and the terminals will cause measurement error.

Note 2: For linear voltage input, if the range is below 500mV, connect to terminals 19 and 18. 0~5V or 1~5V signal can be inputted from terminals 17 and 18.

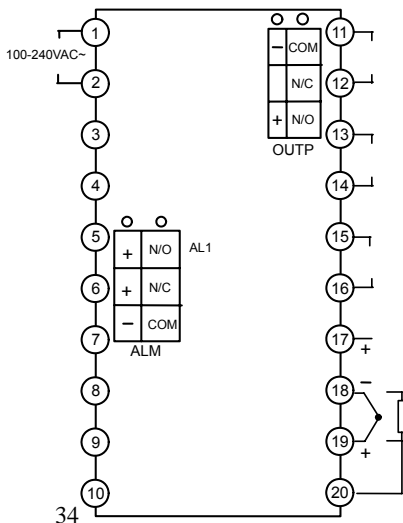

Note: The graph suits for upright instruments with 1/4DIN or 1/16DIN Vertical

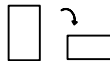

For instruments with horizontal, just clockwise rotate the graph 90 degree.

Wiring graph for 1/16 DIN dimension instruments :

Note 1: 1/16 DIN dimension instruments don't support 0~5V or 1~5V linear voltage input. However, 0~5V or 1~5V signal can be converted to 0~500mV or 100~500mV by connecting external precise resistors, 4~20mA can be converted to 100~500mV by connecting a 25ohm resistor, then be inputted from terminals 8 and 9

Note 2: When AUX need work as alarming function, parameter "bAud" should set to = 0, it will be used for AU1 for alarm output.

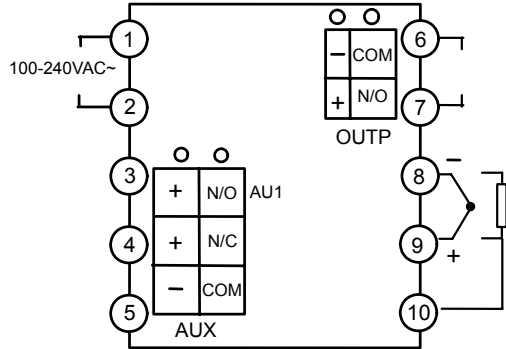

DISPLAYS AND OPERATIONS

- ① Upper display window, displays PV, parameter code, etc.
- ② Lower display window, displays SV, parameter value, or alarm message
- ③ Setup key, for accessing parameter table and conforming parameter modification.
- ④ Data shift key, and auto tuning
- ⑤ Data decrease key, and also run/pause switch
- ⑥ Data increase key, and also stop key
- ⑦ LED indicator. MAN, MIO, AI2, AU2 and COMM indicators is non-applicable.

OP1, AL1 and AU1 LED indicate I/O operation of the corresponding module. RUN LED, which only works for CN44, means that the program control is running.

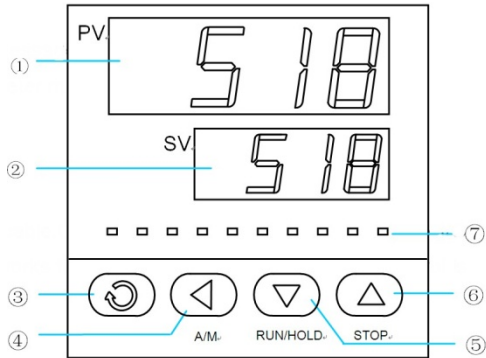

Basic display status:

When power on, the upper display window of the instrument shows the process value (PV), and the lower window shows the set-point (SV). This status is called basic display status.

When the input signal is out of the measurable range (e.g., the thermocouple or RTD circuit is break, or input specification sets wrong), the upper display window will alternately display “oral”, and the instrument will automatically stop output.

If the lower display window alternately display “HIAL”, “LoAL”, “HdAL” or “LdAL”, it means high limit alarm, low limit alarm, deviation high alarm, and deviation low alarm happening.

For programmable controller (CN44): The lower display may alternately display between SV and “StoP”, ”HoLd” or ”rdy” which means the program is stop, pause and ready.

If don't want to display the alarm message, can disable by set ADIS=oFF

OPERATION DESCRIPTION



- **Parameter Setting:**

In basal display status, press  and hold for about 2 seconds can access Field Parameter Table.

Press  can go to the next parameter;





Press ,  or  can modify a parameter.



Press and hold  can return to the preceding parameter.



Press  (don't release) and then press  key simultaneously can escape from the parameter table. The instrument will escape automatically from the parameter table if no key is pressed within 25 seconds.

Set Loc=808 and then press  can access System Parameter Table.

- **Set Value Setting:**

In basal display status, if the parameter lock “Loc” isn't locked, we can set setpoint (SV) by pressing  first, then can ,  or  to adjust value.

Press  key to decrease the value,  key to increase the value, and  key to move to the digit expected to modify.

Keep pressing  or , the speed of decreasing or inscreasing value get quick. The range of setpoint is between the parameter SPL and SPH. The default range is 0 to 400.



- **Control Run and Stop**

Start controlling run: Press  and hold 2 seconds, and let RUN led on. For CN 44, it will start the program run again



Stop Controlling: Press  and hold 2 seconds, and let STOP led on. For CN 44, it will stop the program and Step value will reset to StEP=1.

- **AI control and auto tuning**

When AI control method is chosen (Ctrl=APId / nPIId), the PID parameters can be obtained by running auto-tuning.

In basal display status, press  for 2 seconds, the "At" parameter will appear. Press  to change the value of "At" from "oFF" to "on", then press  to active the auto-tuning process.

During auto tuning, the instrument executes on-off control. After 2-3 times of on-off action, the instrument will obtain the optimal control parameter value.

If you want to escape from auto tuning status, press and hold the  key for about 2 seconds until the "At" parameter appear again. Change "At" from "on" to "oFF", press  to confirm, then the auto tuning process will be cancelled. (P.S. If parameter "SPr" activate and the heating was running, then will stop the "At" until completed the heat up process.)

Note 1: If the setpoint is different, the parameters obtained from auto-tuning are possible different. So you'd better set setpoint to an often-used value or middle value first, and then start auto-tuning.

For the ovens with good heat preservation, the setpoint can be set at the highest applicable temperature. Depending on the system, the auto-tuning time can be from several seconds to several hours.

Note 2: Parameter CHYS (on-off differential, control hysteresis) has influence on the accuracy of auto-tuning. Generally, the smaller the value of CHYS, the higher the precision of auto tuning. But CHYS parameter value should be large enough to prevent the instrument from error action around setpoint due to the oscillation of input. CHYS is recommended to be 2.0.

Note 3: AI series instrument has the function of self-learning. It is able to learn the process while working. The control effect at the first run after auto tuning is probably not perfect, but excellent control result will be obtained after a period of time because of self-learning.

- **Program setting (Only For CN44)**

Press the  key once and release in the display status, the instrument will be in the setup program status. The set point of the current program StEP will be displayed.

Pressing ,  or  can modify the value.

Pressing  can go to next parameter. The program parameters will be displayed in the sequence of setpoint1, time1, setpoint2, time2.

Pressing and holding  for about 2 seconds will return to the previous parameter. Program step can modify anytime even the program still in running.

Run / Hold

In basic display status, if the program is in stoP status (“StoP” is alternately displayed on the lower window), press and hold the  key for about 2 seconds until the lower display window displays the "Run" symbol, the instrument then will start the program.

At running status, press and hold the  key for about 2 seconds until the lower display window displays

the "HoLd" symbol, the instrument changes to hold status.

At Hold status, the program is still executing, and the process value is controlled same as setpoint, but the timer stop working, and the running time and setpoint remains. At Hold status, press and hold the  key for about 2 seconds until the lower display window displays the "Run" symbol, the instrument will back to run program

Stop

Press and hold the  key for about 2 seconds in the basic display status, until the lower display window displays the "stoP" symbol, the stoP operation is executed now, when program stopped, timer will be reset and stop. This operation forces the instrument to stop running, meanwhile, the StEP number will reset to 1, and control output is also stopped

Power cut/resume event handling:

There are 5 events handling method selectable for power resume after power cut. Please refer to parameter PonP.

PV startup and PV preparation function (rdy function) :

At the beginning of starting a program, resuming a program after power cut or continuing to run a program after it is just modified, the PV (process value) are often quite different from the set point. PV startup function and PV preparation function can make PV and set point consistent, and avoid unexpected result. When PV startup function enabled, the instrument will adjust the running time automatically to make the expected set point is the same as the current PV.

For example, the program is set that the temperature will be raised from 25°C to 625°C in 600 minutes. But the current PV is 100°C, then the instrument will automatically to run this program start from 75 minutes, that mean changed the temperature raised from 100°C to 625°C in 525 minutes (600-75) min.

At the above situation(PV=100, SV=25, first step SV), when PV preparation function is enable, the alarm function will be blocked at that time, and PV will be adjusted to approach SV until the deviation alarm condition is released (PV is between SV-LdAL and SV+HdAL). After deviation alarm was off, the controller start the program again. Preparation function (rdy Function) is helpful to keep the integrity of

the program, but it will prolong the program time because the start of the program is postponed. PV startup function is prior to PV preparation function. If both function are enabled, the system apply PV startup first, if PV startup function works, PV preparation function will not be activated.

Curve fitting:

Curve fitting is adopted as a kind of control technology for CN44 series instrument. As controlled process often has lag time in system response, by the way of curve fitting the instrument will smooth the turning point of the linear heating-up, cooling-down and constant temperature curves automatically. The degree of the smooth is relevant with the system's lag time t ($t=d+Ct_l$) ; the longer of the lag time, the curve will more smooth. On the opposite the smooth function will be weaker. Generally the shorter of the process lag time (such as temperature inertia), the better of the program control on effect. By the way of the curve fitting to deal with the program curves, will avoid overshoot. Note: The characteristic of the curve fitting will force the program control to generate fixed negative deviation during the linear heating-up and fixed positive deviation during the linear cooling-down, the deviation is direct proportional to the lag time and the speed of heating-up (cooling-down). This phenomenon is normal.

PARAMETER SETTING FLOW CHART

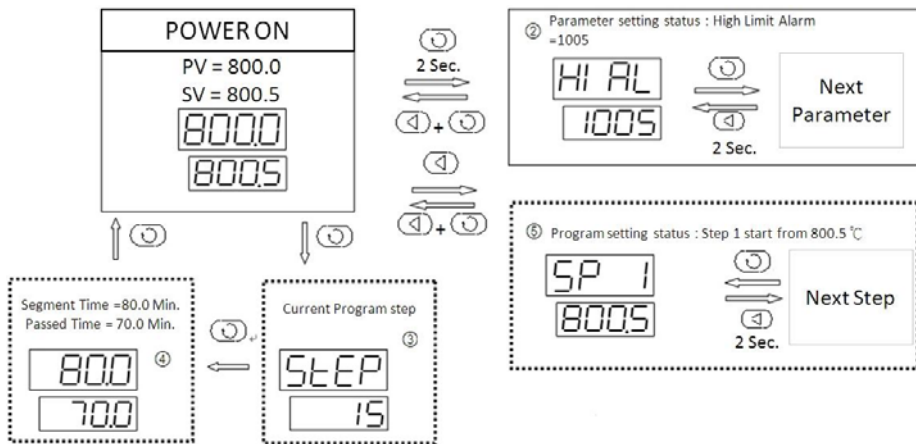

Note: Only CN 44 will display status 3 , 4 and 5

PROGRAMMING AND OPERATION (For CN44 only)

Ramp Mode(PAF : B=0)

Programming of instrument has uniform format of temperature-time-temperature, which means temperature “A”(SP 1), passed Time “A”(t01), then reached Temperature “B”(SP 2). The unit of temperature set is °C and the unit of time set is minute. The following example includes 5 steps, which is linear temperature heating up, constant temperature, linear temperature cooling down, jump cycling, ready, Hold..

StEP1: SP 1=100.0, t 1=30.0 Start linear temperature heating up from 100°C, and the time needed 30 minutes to reach SP 2(400 degree).

StEP2: SP 2=400.0, t 2=60.0 Temperature raised to 400°C, slope of raising curve is 10°C/minute, The program take 60 minutes to raise temperature to SP3 (400 degree). It means keep the same temperature in 60 minutes.

StEP3: SP 3=400.0, t 3=120.0 This is the step for temperature cooling down, slope of cooling curve is

2°C/minute, and the time needed is 120 minutes to reach SP4 (160degree).

StEP4: SP 4=160.0, t 4=0.0 When temperature reached 160 degree, the program get in Hold state. If need go to next step, it needed operator to executed the “run” for next step.

StEP5: SP 5=160.0, t05=-1.0 Jump to StEP1 to start from beginning.

In this example, it is assumed that the deviation high alarm is set to 5°C . Because the temperature of StEP 5 is 160°C , and the temperature of StEP1 is 100°C , when program jumps from StEP 5 to StEP 1, the program will change to preparation state at first(if preparation mode “rdy” was enabled), i.e., Control the temperature until the deviation between setpoint and PV is less than deviation high alarm value. After temperature is controlled to 105°C , the program will be started from StEP 1, and run the above steps again. The temperature control drawing was shown below.

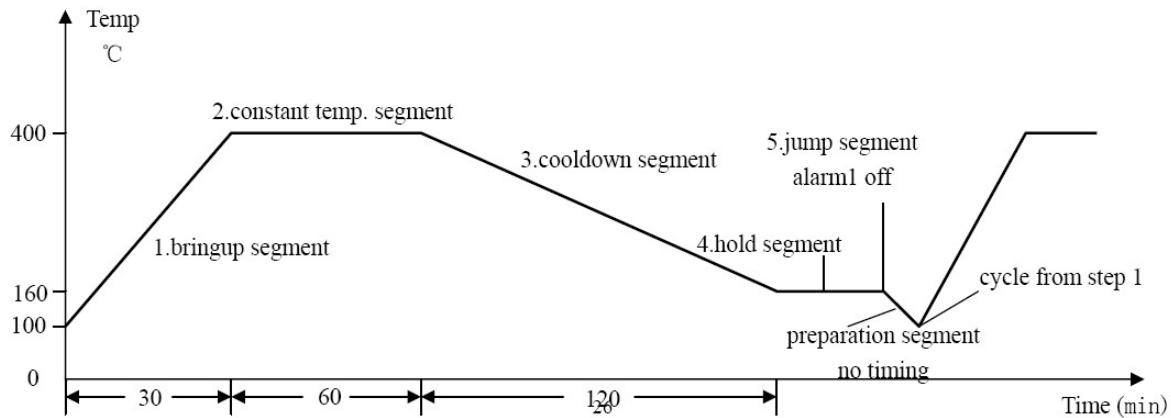

Soak mode(PAF : B=1)

Suitable for the process which does not need to establish the temperature slope, can simplify the programming and more effective. Each step also can set parameter "SPr" to define temperature raise

slope, if “SPr=0” raising speed will set to maximum. Because cannot know the actual time which spend on temperature raising, user can enable “rdy” function to ensure the correct soak time.

Time setting

Set “t-xx” = 0.1 ~ 3200 (min)

Set the time of xx StEP. (Time units can be change to Hour by parameter “PAF”.)

Set “t-xx” = 0.0

The program hold on StEP xx, program will hold running and hold counting time.

Set “t-xx” = -121.0

The program stops, and switches to stop status.

Set “t-xx” = -0.1 ~ -122.0

Negative value of this range represents a jump operation which will jump to step xx and event output.

Range -1~-120 is for step jumping application. The step jumping cannot greater than “Pno”(No. of Program step).

Decimal point use for control the event output from AL1 and AL2. (Modular), Note, if parameter AOP was assigned alarm action will trigger from AL1 and AL2, the event output also will cause alarm from AL1 and AL2.

When set

-XXX.1, AL1 activate, AL2 release

-XXX.2, AL1 release, AL2 activate

-XXX.3, AL1 and AL2 activate

-XXX.4, AL1 and AL2 release

Example:

Example 1 : t -5 = -1.1 ; means when the program arrived step 5, AL1 activate, AL2 release and will jump to step 1 continues running

Example 2 : t-6 = -0.3 ; means when the program arrived step 6, AL1 and AL2 activate and continuous next step.

Note: The program will be held if it jump from a control segment to another control segment (an Hold

action will be inserted between two control sections), external run/Hold operation is needed to release the Hold status. It is not allowed that the jump section jump to itself (for example: t 06= -6), otherwise, the Hold status cannot be released.

Program arrangement of multi-curve operation

CN 44 has the advanced function of flexible program arrangement. Normally, when the program stops, the StEP will be automatically set to 1. Thus if StEP is not change to other value, a program will start from step 1. If multiple curves are defined, the control can jump to different curve by setting step 1 as jump segment.

For example: There are three curves with the length of 3 steps represent three groups of process parameter, they are separately arranged on StEP2-StEP4, StEP5-StEP7, StEP8-StEP10. Settings are as follows:

t -1=-2.0 Execute the program of curve 1 (StEP2-StEP4)

t -1=-5.0 Execute the program of curve 2 (StEP5-StEP7)

t -1=-8.0 Execute the program of curve 3 (StEP8-StEP10)

Note: Can choose the curves by setting the value of StEP “t-1” set to -2, -5 or -8 before the program startup.



WARRANTY/DISCLAIMER

OMEGA ENGINEERING, INC. warrants this unit to be free of defects in materials and workmanship for a period of **25 months** from date of purchase. OMEGA's WARRANTY adds an additional one (1) month grace period to the normal **two (2) year product warranty** to cover handling and shipping time. This ensures that OMEGA's customers receive maximum coverage on each product.

If the unit malfunctions, it must be returned to the factory for evaluation. OMEGA's Customer Service Department will issue an Authorized Return (AR) number immediately upon phone or written request. Upon examination by OMEGA, if the unit is found to be defective, it will be repaired or replaced at no charge. OMEGA's WARRANTY does not apply to defects resulting from any action of the purchaser, including but not limited to mishandling, improper interfacing, operation outside of design limits, improper repair, or unauthorized modification. This WARRANTY is VOID if the unit shows evidence of having been tampered with or shows evidence of having been damaged as a result of excessive corrosion; or current, heat, moisture or vibration; improper specification; misapplication; misuse or other operating conditions outside of OMEGA's control. Components in which wear is not warranted, include but are not limited to contact points, fuses, and triacs.

OMEGA is pleased to offer suggestions on the use of its various products. However, OMEGA neither assumes responsibility for any omissions or errors nor assumes liability for any damages that result from the use of its products in accordance with information provided by OMEGA, either verbal or written. OMEGA warrants only that the parts manufactured by the company will be as specified and free of defects. OMEGA MAKES NO OTHER WARRANTIES OR REPRESENTATIONS OF ANY KIND WHATSOEVER, EXPRESSED OR IMPLIED, EXCEPT THAT OF TITLE, AND ALL IMPLIED WARRANTIES INCLUDING ANY WARRANTY OF MERCHANTABILITY AND FITNESS FOR A PARTICULAR PURPOSE ARE HEREBY DISCLAIMED. LIMITATION OF LIABILITY: The remedies of purchaser set forth herein are exclusive, and the total liability of OMEGA with respect to this order, whether based on contract, warranty, negligence, indemnification, strict liability or otherwise, shall not exceed the purchase price of the component upon which liability is based. In no event shall OMEGA be liable for consequential, incidental or special damages.

CONDITIONS: Equipment sold by OMEGA is not intended to be used, nor shall it be used: (1) as a "Basic Component" under 10 CFR 21 (NRC), used in or with any nuclear installation or activity; or (2) in medical applications or used on humans. Should any Product(s) be used in or with any nuclear installation or activity, medical application, used on humans, or misused in any way, OMEGA assumes no responsibility as set forth in our basic WARRANTY/DISCLAIMER language, and, additionally, purchaser will indemnify OMEGA and hold OMEGA harmless from any liability or damage whatsoever arising out of the use of the Product(s) in such a manner.

RETURN REQUESTS/INQUIRIES

Direct all warranty and repair requests/inquiries to the OMEGA Customer Service Department. **BEFORE RETURNING ANY PRODUCT(S) TO OMEGA, PURCHASER MUST OBTAIN AN AUTHORIZED RETURN (AR) NUMBER FROM OMEGA'S CUSTOMER SERVICE DEPARTMENT (IN ORDER TO AVOID PROCESSING DELAYS).** The assigned AR number should then be marked on the outside of the return package and on any correspondence.

The purchaser is responsible for shipping charges, freight, insurance and proper packaging to prevent breakage in transit.

FOR **WARRANTY RETURNS**, please have the following information available **BEFORE** contacting OMEGA:

1. Purchase Order number under which the product was **PURCHASED**,
2. Model and serial number of the product under warranty, and
3. Repair instructions and/or specific problems relative to the product.

FOR **NON-WARRANTY REPAIRS**, consult OMEGA for current repair charges. Have the following information available **BEFORE** contacting OMEGA:

1. Purchase Order number to cover the **COST** of the repair,
2. Model and serial number of the product, and
3. Repair instructions and/or specific problems relative to the product.

OMEGA's policy is to make running changes, not model changes, whenever an improvement is possible. This affords our customers the latest in technology and engineering.

OMEGA is a registered trademark of OMEGA ENGINEERING, INC.

© Copyright 2006 OMEGA ENGINEERING, INC. All rights reserved. This document may not be copied, photocopied, reproduced, translated, or reduced to any electronic medium or machine-readable form, in whole or in part, without the prior written consent of OMEGA ENGINEERING, INC.

Where Do I Find Everything I Need for Process Measurement and Control? OMEGA...Of Course!

Shop online at www.omega.com

TEMPERATURE

- ☑ Thermocouple, RTD & Thermistor Probes, Connectors, Panels & Assemblies
- ☑ Wire: Thermocouple, RTD & Thermistor
- ☑ Calibrators & Ice Point References
- ☑ Recorders, Controllers & Process Monitors
- ☑ Infrared Pyrometers

PRESSURE, STRAIN AND FORCE

- ☑ Transducers & Strain Gages
- ☑ Load Cells & Pressure Gages
- ☑ Displacement Transducers
- ☑ Instrumentation & Accessories

FLOW/LEVEL

- ☑ Rotameters, Gas Mass Flowmeters & Flow Computers
- ☑ Air Velocity Indicators
- ☑ Turbine/Paddlewheel Systems
- ☑ Totalizers & Batch Controllers

pH/CONDUCTIVITY

- ☑ pH Electrodes, Testers & Accessories
- ☑ Benchtop/Laboratory Meters
- ☑ Controllers, Calibrators, Simulators & Pumps
- ☑ Industrial pH & Conductivity Equipment

DATA ACQUISITION

- ☑ Data Acquisition & Engineering Software
- ☑ Communications-Based Acquisition Systems
- ☑ Plug-in Cards for Apple, IBM & Compatibles
- ☑ Datalogging Systems
- ☑ Recorders, Printers & Plotters

HEATERS

- ☑ Heating Cable
- ☑ Cartridge & Strip Heaters
- ☑ Immersion & Band Heaters
- ☑ Flexible Heaters
- ☑ Laboratory Heaters

ENVIRONMENTAL MONITORING AND CONTROL

- ☑ Metering & Control Instrumentation
- ☑ Refractometers
- ☑ Pumps & Tubing
- ☑ Air, Soil & Water Monitors
- ☑ Industrial Water & Wastewater Treatment
- ☑ pH, Conductivity & Dissolved Oxygen Instruments

M-4546/0208