

LDP6-CDC4 MODBUS Communication Option Card

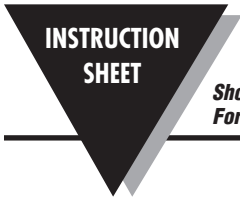

M4540-0607

Shop online at: omega.com e-mail: info@omega.com
 For latest product manuals: omegamanual.info

DESCRIPTION

This product bulletin covers the MODBUS Communication Card for the PTC9, DPF93, and the LDP6 family of meters. The card will allow the Meter to

transmit Display Values, Setpoints and Reset Values via MODBUS RS485 communication, in the RTU and ASCII modes.

INSTALLING AN OPTION CARD



Caution: The option and main circuit cards contain static sensitive components. Before handling the cards, discharge static charges from your body by touching a grounded bare metal object. Ideally, handle the cards at a static controlled clean workstation. Also, only handle the cards by the edges. Dirt, oil or other contaminants that may contact the cards can adversely affect circuit operation.



Warning: Exposed line voltage exists on the circuit boards. Remove all power to the meter AND load circuits before accessing the unit.

1. Remove the main assembly from the rear of the case. Squeeze the finger holds on the rear cover, or use a small screwdriver to depress the side latches to release it from the case. It is not necessary to separate the rear cover from the main circuit card.
2. Locate the option card connector for the type of option card to be installed. Hold the unit by the rear connector, not the display board, when installing an option card.
3. Install the option card by aligning the option card connector with the slot in the rear cover. The cards are keyed by position with different main board connector locations. Be sure the connector is fully engaged and the tab on the option card rests in the alignment slot on the display board.
4. Slide the assembly back into the case. Be sure the rear cover latches fully into the case.
5. Apply the option card label to the bottom side of the meter. Do not cover the vents on the top surface of the meter. The surface of the case must be clean for the label to adhere properly. Apply the label to the area designated by the large case label.
6. See manual for wiring connections and programming procedures.

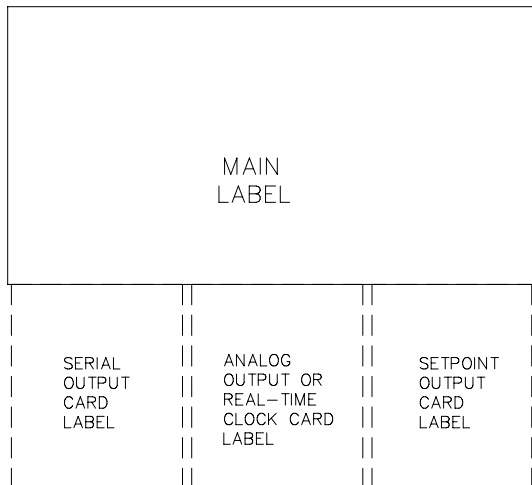
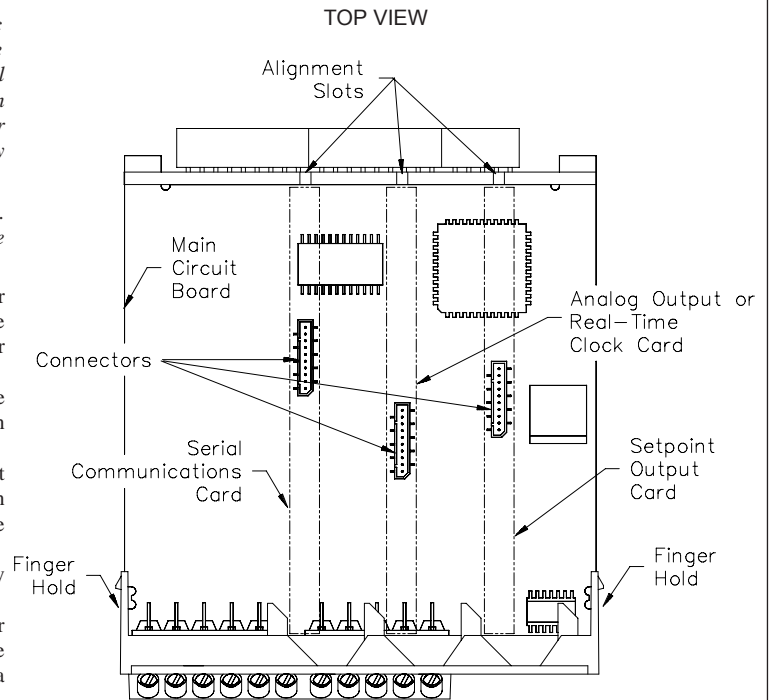

MODBUS SPECIFICATIONS

1. **Type:** RS485; RTU and ASCII MODBUS modes
2. **Isolation To Sensor & User Input Commons:** 500 Vrms for 1 minute. Working Voltage: 50 V. Not isolated from all other commons.
3. **Baud Rates:** 300 to 38400.
4. **Data:** 7/8 bits
5. **Parity:** No, Odd, or Even
6. **Addresses:** 1 to 247.
7. **Transmit Delay:** Programmable; See Transmit Delay explanation.

RS485 COMMUNICATIONS

The RS485 communication standard allows the connection of up to 32 devices on a single pair of wires, distances up to 4,000 ft. and data rates as high as 10M baud. The same pair of wires is used to both transmit and receive data. RS485 is therefore always half-duplex, that is, data cannot be received and transmitted simultaneously.

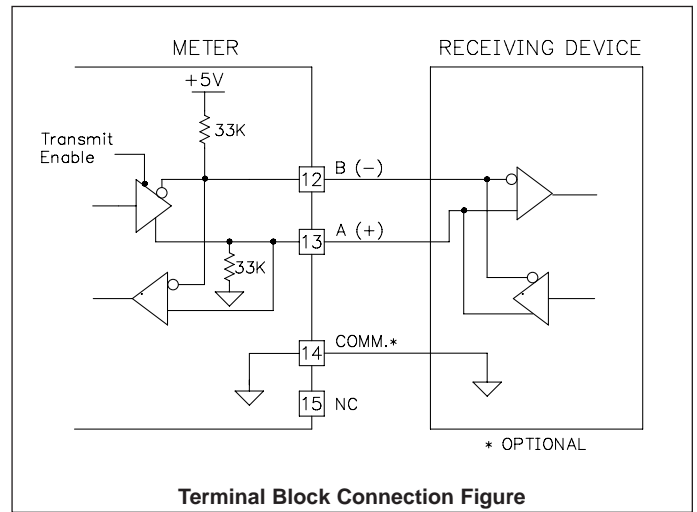
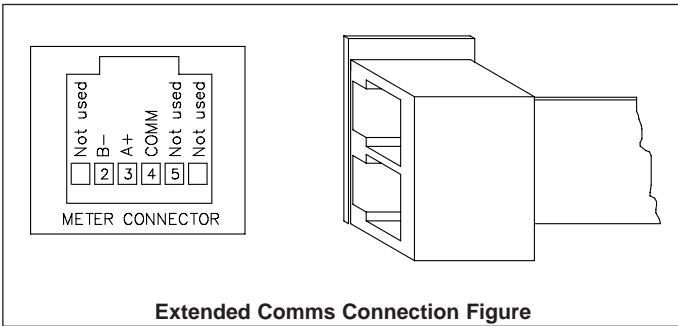

SERIAL SET-UP DIP SWITCH OPERATION

Serial port configuration is accomplished through two banks of DIP switches on the MODBUS card. The bank of 8 switches sets the Unit Address, the bank of 7 switches sets the Serial port parameters (ASCII/RTU, 7/8 bits, Parity, and Baud rate). Changes to the switch settings are only detected on power-up of the unit. After changing a switch setting, power to the unit must be cycled for the new switch setting to take effect.

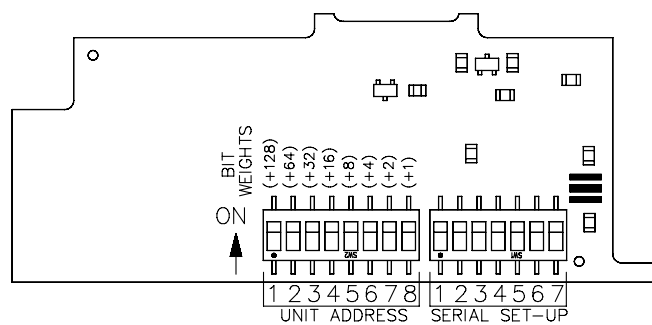

For the serial bank, the following settings apply:

SWITCH	SETTINGS AVAILABLE		FACTORY SETTINGS
1	OFF: ASCII	ON: RTU	RTU
2	OFF: 7 Bits	ON: 8 Bits	8 Bits
3	OFF: None	ON: Parity	No Parity
4	OFF: Even	ON: Odd	OFF
5	Baud Rate	(See Baud Rate Switch Selections)	9600
6	Baud Rate		
7	Baud Rate		

BAUD RATE SWITCH SELECTIONS

	5	6	7
38400:	ON	ON	ON
19200:	ON	ON	OFF
9600:	ON	OFF	ON
4800:	ON	OFF	OFF
2400:	OFF	ON	ON
1200:	OFF	ON	OFF
600:	OFF	OFF	ON
300:	OFF	OFF	OFF

Both unit address and serial set-up are set via DIP switches on the MODBUS option card. See the DIP switch setting table for more details on these DIP switches.

For the Unit Address bank, the high order bit is switch 1, and the ON position is a '1', the OFF position is a '0'. Legal unit addresses are 1 to 247. When a Unit Address of 0 is selected, the card responds to Unit Address 1. When a Unit Address of 248 through 255 is selected, the card responds to Unit Address 247.

METER TYPE DEFINITION

The LDP6-CDC40 MODBUS communication option card returns different values for both register and coil values dependent on the type of meter the card is used with. The three types of meter are:

METER TYPE	MODELS
Analog	DP63500, DP63600, DP63700, DP63800, DP63900, LDP63000, LDP63100
Digital	DPF9300, LDPF63000, LDPF63100
Timers	PTC900, PTC901

MODBUS SUPPORTED FUNCTION CODES

COIL FUNCTIONS

FC01: Read Coils

FC05: Force Single Coil, FC15: Force Multiple Coils.

- Valid coil addresses are 1-49.
- Block starting point can not exceed coil 49.

HOLD REGISTER FUNCTIONS

FC03: Read Holding Registers.

FC06: Preset Single Register, FC16: Preset Multiple Registers.

- Valid register address are 40001 – 40039, 40041, 40042, 41001 – 41010.
- Up to 16 registers can be requested at one time.
- Block starting point can not exceed the register boundaries.
- Holding registers are a mirror of Input registers (FC04).
- Unused registers will return a value of HEX <8000>.
- If a register is implemented, but does not exist for a particular unit configuration (such as SP3, SP4) a value of HEX <0000> will be returned.
- Registers 41001 – 41010 contain the slave ID. See FC17.
- Broadcast write is supported for FC06 & FC16. Register writes using address “0” will be recognized by the MODBUS card, regardless of address DIP switch setting.

OTHER SUPPORTED FUNCTIONS

FC04:

Returns the same values as FC03, except the register number starts with “3”
(Ex: Input Hi is 30001)

FC08 – Fetch Comm. Event Counter.

The MODBUS response breaks down as follows:

```
“:010804”<TOT HI><TOT LO><GOOD HI><GOOD LO>XX<CR><LF>
```

The “TOT HI” and “TOT LO” values are the total number of messages that were received, that started with the card’s address. The “GOOD HI” and “GOOD LO” are “good” messages (correct address, parity, and checksum). The values are reset on power up and every time the FC08 function is requested.

FC17 - Report Slave ID.

The following is sent upon FC17 request:

```
Unit Address, 17 (FC code), RLC-PAX(I or ?) 00?0, 0100 (for code version 1.00), 16 (number of read supported registers), 16 (number of write supported registers), 00 (number of registers available for GUID/Scratch pad memory), checksum of the string.
```

The following is the HEX of a DPF93 (with unit address of 247):

```
:<F7><11><14><52><4C><43><2D><50><41><58><49><30><30><3F><30><01><00><00><10><00><10><00><00><XX><CR><LF>
```

XX is the LRC Checksum

MANUAL MODE DESCRIPTION

(CSR) Control Status Register [40021] (Analog)

The Control Status Register is used to directly control the meter’s outputs (setpoints and analog output), or view the state of the setpoint outputs and the status of the temperature sensor (DP63500 only). The register is bit mapped with each bit position within the register assigned to a particular control function. The control functions are invoked by writing to each bit position. The bit position definitions are:

bit 0: SP1 Output	} 0 = output off 1 = output on	bit 5: Always stays 0, even if 1 is sent.
bit 1: SP2 Output		bit 6: Sensor Status (DP63500 only)
bit 2: SP3 Output		0 = sensor normal
bit 3: SP4 Output		1 = sensor fail
bit 4: Manual Mode		bit 7: Always stays 0, even if 1 is sent.
0 = automatic mode		
1 = manual mode		

In Manual Mode, the setpoint outputs are defined by the values written to bits b0, b1, b2, b3; and the analog output is defined by the value written to the AOR. Internal control of these outputs is then overridden. In automatic mode, the setpoint outputs can only be reset off.

(MMR) Auto/Manual Mode Register [40036] (Digital/Timer)

This register sets the controlling mode for the outputs. In Auto Mode (0) the meter controls the setpoint output. In Manual Mode (1) the outputs are defined by the registers SOR. When transferring from auto mode to manual mode, the meter holds the last output value (until the register is changed by a write). Each output may be independently changed to auto or manual. Select values to place in manual mode by writing appropriate value to holding register 40036. The bit position definitions are:

DIGITAL		TIMER	
bit 0: Analog Output	} 0 = Auto Mode 1 = Manual Mode	bit 0: SP4	} 0 = Auto Mode 1 = Manual Mode
bit 1: SP4		bit 1: SP3	
bit 2: SP3		bit 2: SP2	
bit 3: SP2		bit 3: SP1	
bit 4: SP1			

Examples:

- Select manual mode for all outputs and AOR:
Value to write to holding register 40036: 001Fh

(SOR) Setpoint Output Register [40038] (Digital/Timer)

This register is used to view or change the states of the setpoint outputs. Reading from this register will show the present state of all the setpoint outputs. A “0” in the setpoint location means the output is inactive and a “1” means the output is active.

In Automatic Mode (See MMR Description), the meter controls the setpoint output state. In Manual Mode, writing to this register will change the output state. The bit position definitions are:

bit 0: SP1	} 0 = Output off 1 = Output on
bit 1: SP2	
bit 2: SP3	
bit 3: SP4	

Examples:

- Turn all outputs on:
Value to write to holding register 40038: 000Fh.
- Turn outputs 1, 3 on:
Value to write to holding register 40038: 0005h.
- Turn all outputs off:
Value to write to holding register 40038: 0000h.

(AOR) Analog Output Register (Not Timer)

The Analog Output Register controls the analog output of the meter. The manual mode must first be engaged by setting bit 4 of the CSR (Analog) or bit 0 of the MMR (Digital). The range of values of this register is 0 to 4095, which corresponds to 0 mA, 0 V and 20 mA, 10 V; respectively. If a value larger than 4095 is written to the AOR register, 4095 will be loaded. The table lists correspondence of the output signal with the register value.

Register Value	Output Signal*	
	I (mA)	V (V)
0	0.000	0.000
1	0.005	0.0025
2047	10.000	5.000
4094	19.995	9.9975
4095	20.000	10.000

*Due to the absolute accuracy rating and resolution of the output card, the actual output signal may differ 0.15% FS from the table values. The output signal corresponds to the range selected (20 mA or 10 V).

Writing to this register while the meter is in the manual mode causes the output signal to update immediately. While in the automatic mode, this register may be written to, but the output will not update until the meter is placed in manual mode.

Examples:

- Set output to full scale:
Value to write to holding register 40020 (Analog) or 40037 (Digital): 0FFFh (4095).
- Set output to zero scale:
Value to write to holding register 40020 (Analog) or 40037 (Digital): 0000h (0).

HOLDING REGISTERS

HOLDING REGISTER	SETTING		
	ANALOG	DIGITAL	TIMER
40001:	Input (HI)	CTA (HI)	Timer (HI)
40002:	Input (LO)	CTA (LO)	Timer (LO)
40003:	Total (HI)	CTB (HI)	Counter (HI)
40004:	Total (LO)	CTB (LO)	Counter (LO)
40005:	Min (HI)	CTC (HI)	RTC Time (HI)
40006:	Min (LO)	CTC (LO)	RTC Time (LO)
40007:	Max (HI)	RTE (HI)	RTC Date (HI)
40008:	Max (LO)	RTE (LO)	RTC Date (LO)
40009:	SP1 (HI)	Min (HI)	SP1 (HI)
40010:	SP1 (LO)	Min (LO)	SP1 (LO)
40011:	SP2 (HI)	Max (HI)	SP2 (HI)
40012:	SP2 (LO)	Max (LO)	SP2 (LO)
40013:	SP3 (HI)	SFA (HI)	SP3 (HI)
40014:	SP3 (LO)	SFA (LO)	SP3 (LO)
40015:	SP4 (HI)	SFB (HI)	SP4 (HI)
40016:	SP4 (LO)	SFB (LO)	SP4 (LO)
40017:	Polling1 *	SFC (HI)	SP1 Off (HI)
40018:	Reset *	SFC (LO)	SP1 Off (LO)
40019:	TRX Delay ³	LDA (HI)	SP2 Off (HI)
40020:	AOR ²	LDA (LO)	SP2 Off (LO)
40021:	CSR	LDB (HI)	SP3 Off (HI)
40022:	Terminate1	LDB (LO)	SP3 Off (LO)

HOLDING REGISTER	SETTING		
	ANALOG	DIGITAL	TIMER
40023:	——	LDC (HI)	SP4 Off (HI)
40024:	——	LDC (LO)	SP4 Off (LO)
40025:	——	SP1 (HI)	Timer Start (HI)
40026:	——	SP1 (LO)	Timer Start (LO)
40027:	——	SP2 (HI)	Counter Start (HI)
40028:	——	SP2 (LO)	Counter Start (LO)
40029:	——	SP3 (HI)	Timer Stop (HI)
40030:	——	SP3 (LO)	Timer Stop (LO)
40031:	——	SP4 (HI)	Counter Stop (HI)
40032:	——	SP4 (LO)	Counter Stop (LO)
40033:	——	Polling1 *	Polling1 *
40034:	——	Polling2 *	Polling2 *
40035:	——	TRX Delay ³	TRX Delay ³
40036:	——	MMR	MMR
40037:	——	AOR ²	RTC Day
40038:	——	SOR	SOR
40039:	——	Reset *	Reset *
40040:	——		
40041:	——	Terminate1	Terminate1
40042:	——	Terminate2	Terminate2

* See Coil Table for register mapping and Coil Descriptions for functionality.

Notes:

1. Any registers marked with “——” are unused and will return a value of HEX <8000>.
2. If a value larger than 4095 is written to the AOR register, 4095 will be loaded.
3. TRX delay is the minimum time from the reception of the last character in the MODBUS Query until the response is started. The minimum delay value is equal to 2 character times (2 msec min.). The user can increase the delay time by writing to the TRX Delay register. Any value written to the TRX Delay register that is less than the value calculated at power up will be ignored. The TRX Delay value is stored in E²PROM memory. On power-up, the calculated value is compared to the value read back from the E²PROM. The greater of the 2 values will be used as the TRX Delay value and will be written to the TRX Delay register.

COIL TABLE

COIL ADDRESS	COIL NUMBER	ANALOG		DIGITAL		TIMER	
		COIL NAME	MIRROR REGISTER	COIL NAME	MIRROR REGISTER	COIL NAME	MIRROR REGISTER
01	0	SP1 Output	40021 (bit 0)	SP1 Output	40038 (bit 0)	SP1 Output	40038 (bit 0)
02	1	SP2 Output	40021 (bit 1)	SP2 Output	40038 (bit 1)	SP2 Output	40038 (bit 1)
03	2	SP3 Output	40021 (bit 2)	SP3 Output	40038 (bit 2)	SP3 Output	40038 (bit 2)
04	3	SP4 Output	40021 (bit 3)	SP4 Output	40038 (bit 3)	SP4 Output	40038 (bit 3)
05	4	Reset Max	40018 (bit 2)	Reset Max	40039 (bit 2)	——	——
06	5	Reset Min	40018 (bit 3)	Reset Min	40039 (bit 3)	——	——
07	6	——	——	Reset CNT A	40039 (bit 7)	Reset Timer	40039 (bit 7)
08	7	——	——	Reset CNT B	40039 (bit 6)	Reset Counter	40039 (bit 6)
09	8	——	——	Reset CNT C	40039 (bit 5)	——	——
10	9	Reset Total	40018 (bit 4)	——	——	——	——
11	10	Poll Input	40017 (bit 0)	Poll CNT A	40033 (bit 0)	Poll Timer	40033 (bit 0)
12	11	Poll Total	40017 (bit 1)	Poll CNT B	40033 (bit 1)	Poll Counter	40033 (bit 1)
13	12	Poll Max	40017 (bit 2)	Poll MAX	40033 (bit 2)	Poll SP2	40033 (bit 2)
14	13	Poll Min	40017 (bit 3)	Poll MIN	40033 (bit 3)	Poll SP1	40033 (bit 3)
15	14	Poll SP1	40017 (bit 4)	Poll SP1	40033 (bit 4)	Poll Timer Start	40033 (bit 4)
16	15	Poll SP2	40017 (bit 5)	Poll SP2	40033 (bit 5)	Poll Counter Start	40033 (bit 5)
17	16	Poll SP3	40017 (bit 6)	Poll SP3	40033 (bit 6)	Poll Timer Stop	40033 (bit 6)
18	17	Poll SP4	40017 (bit 7)	Poll SP4	40033 (bit 7)	Poll Counter Stop	40033 (bit 7)
19	18	Poll AOR	40017 (bit 8)	Poll AOR	40033 (bit 8)	Poll Day	40033 (bit 8)
20	19	Poll CSR	40017 (bit 9)	Poll SOR	40033 (bit 9)	Poll SOR	40033 (bit 9)
21	20	Term Total	40022 (bit 0)	Poll CNT C	40033 (bit 10)	Poll RTC Time	40033 (bit 10)
22	21	Term Max	40022 (bit 1)	Poll RATE	40033 (bit 11)	Poll RTC Date	40033 (bit 11)
23	22	Term Min	40022 (bit 2)	Poll SFA	40033 (bit 12)	Poll SP3	40033 (bit 12)
24	23	Term SP1	40022 (bit 3)	Poll SFB	40033 (bit 13)	Poll SP4	40033 (bit 13)
25	24	Term SP2	40022 (bit 4)	Poll SFC	40033 (bit 14)	Poll SP1 Off	40033 (bit 14)
26	25	Term SP3	40022 (bit 5)	Poll LDA	40033 (bit 15)	Poll SP2 Off	40033 (bit 15)
27	26	Term SP4	40022 (bit 6)	Poll LDB	40034 (bit 0)	Poll SP3 Off	40034 (bit 0)
28	27	Term AOR	40022 (bit 7)	Poll LDC	40034 (bit 1)	Poll SP4 Off	40034 (bit 1)
29	28	Term CSR	40022 (bit 8)	Poll MMR	40034 (bit 2)	Poll MMR	40034 (bit 2)
30	29	Response Delay	40017 (bit 10)	Response Delay	40034 (bit 3)	Response Delay	40034 (bit 3)
31	30	——	——	Term CNT A	40041 (bit 0)	Term Timer	40041 (bit 0)
32	31	——	——	Term CNT B	40041 (bit 1)	Term Count	40041 (bit 1)
33	32	——	——	Term CNT C	40041 (bit 2)	Term RTC Time	40041 (bit 2)
34	33	——	——	Term Rate	40041 (bit 3)	Term RTC Date	40041 (bit 3)
35	34	——	——	Term Min	40041 (bit 4)	Term SP1	40041 (bit 4)
36	35	——	——	Term Max	40041 (bit 5)	Term SP2	40041 (bit 5)
37	36	——	——	Term SFA	40041 (bit 6)	Term SP3	40041 (bit 6)
38	37	——	——	Term SFB	40041 (bit 7)	Term SP4	40041 (bit 7)
39	38	——	——	Term SFC	40041 (bit 8)	Term SP1 Off	40041 (bit 8)
40	39	——	——	Term LDA	40041 (bit 9)	Term SP2 Off	40041 (bit 9)
41	40	——	——	Term LDB	40041 (bit 10)	Term SP3 Off	40041 (bit 10)
42	41	——	——	Term LDC	40041 (bit 11)	Term SP4 Off	40041 (bit 11)
43	42	——	——	Term SP1	40041 (bit 12)	Term Time Start	40041 (bit 12)
44	43	——	——	Term SP2	40041 (bit 13)	Term Count Start	40041 (bit 13)
45	44	——	——	Term SP3	40041 (bit 14)	Term Time Stop	40041 (bit 14)
46	45	——	——	Term SP4	40041 (bit 15)	Term Count Stop	40041 (bit 15)
47	46	——	——	Term AOR	40042 (bit 0)	Term MMR	40042 (bit 0)
48	47	——	——	Term MMR	40042 (bit 1)	Term Day	40042 (bit 1)
49	48	——	——	Term SOR	40042 (bit 2)	Term SOR	40042 (bit 2)

COIL DESCRIPTIONS

Coils 1-4: Output Coils

These coils are used to read or change the states of the Setpoint Outputs. To change the state of the output(s), the output(s) must be in manual mode. Refer to the CSR or MMR/SOR registers in the Manual Mode Description section.

Coils 5-10: Reset Coils

These coils are used to perform the Reset command for the values listed. Forcing the coil "on" causes the appropriate value in the unit to be reset. The coil is cleared after the command is executed, therefore, the coil value read will always be 0 (zero).

Coils 11-29: Polling Coils

The MODBUS card is continually requesting values from the unit. The polling bit coils determine what values are requested during each loop. Setting the coils to "1" enables the card to poll that particular value. A "0" value disables it. Turning polling coils off allows the user to request fewer values and therefore decreases the internal loop time, which allows the values that are polled to be updated more often.

If a MODBUS read is issued for any value, that value is automatically updated to the latest value, regardless of whether the polling bit is on or off. On power up, all values are updated regardless of Polling bit settings. Polling coil values are saved in E²PROM memory. Factory settings is "on" for all Polling coils.

TYPICAL UPDATE TIMES**	
ANALOG	DIGITAL/TIMER
All values (10) - 1.15 sec	All values (19) - 900 msec
5 values - 500 msec	10 values - 480 msec
1 value - 100 msec	5 values - 230 msec
	1 value - 52 msec

**Update time is the typical time to update the internal memory provided no MODBUS requests are incoming.

Coils 21-29 (Analog), Coils 31-49 (Digital/Timer): Terminating Coils

This set of coils determines what terminating character is sent to the meter when a write command is executed. If the flag is 0, a \$ is used as the terminating character and the value is not saved to E²PROM memory in the meter. If the flag is 1, an * is used as the terminating character and the value is saved to E²PROM memory in the meter.

Coil 30: Response Delay

When a write command is issued, the new value is written to the meter. If the coil is off, the MODBUS write response is not issued until the value is read back from the meter. For MODBUS reads, if a polling coil is off, the response is not issued until the latest value is read back from the meter. If the coil is set "on" the MODBUS response is issued as soon the received command is complete. The write coil is saved in E²PROM memory. Factory setting is on.



OMEGAnet® Online Service
omega.com

Internet e-mail
info@omega.com

Servicing North America:

U.S.A.:
ISO 9001 Certified
One Omega Drive, P.O. Box 4047
Stamford, CT 06907-0047
TEL: (203) 359-1660
FAX: (203) 359-7700
e-mail: info@omega.com

Canada:
976 Bergar
Laval (Quebec) H7L 5A1, Canada
TEL: (514) 856-6928
FAX: (514) 856-6886
e-mail: info@omega.ca

For immediate technical or application assistance:

U.S.A. and Canada: Sales Service: 1-800-826-6342/1-800-TC-OMEGA®
Customer Service: 1-800-622-2378/1-800-622-BEST®
Engineering Service: 1-800-872-9436/1-800-USA-WHEN®

Mexico:
En Español: (001) 203-359-7803
e-mail: espanol@omega.com
FAX: (001) 203-359-7807
info@omega.com.mx

Servicing Europe:

Czech Republic:
Frystatska 184, 733 01 Karviná, Czech Republic
TEL: +420 (0)59 6311899
FAX: +420 (0)59 6311114
Toll Free: 0800-1-66342
e-mail: info@omegashop.cz

Germany/Austria:
Daimlerstrasse 26, D-75392 Deckenpfronn, Germany
TEL: +49 (0)7056 9398-0
FAX: +49 (0)7056 9398-29
Toll Free in Germany: 0800 639 7678
e-mail: info@omega.de

United Kingdom:
ISO 9002 Certified
One Omega Drive, River Bend Technology Centre
Northbank, Irlam, Manchester
M44 5BD United Kingdom
TEL: +44 (0)161 777 6611
FAX: +44 (0)161 777 6622
Toll Free in United Kingdom: 0800-488-488
e-mail: sales@omega.co.uk

It is the policy of OMEGA Engineering, Inc. to comply with all worldwide safety and EMC/EMI regulations that apply. OMEGA is constantly pursuing certification of its products to the European New Approach Directives. OMEGA will add the CE mark to every appropriate device upon certification.

The information contained in this document is believed to be correct, but OMEGA accepts no liability for any errors it contains, and reserves the right to alter specifications without notice. WARNING : These products are not designed for use in, and should not be used for, human applications.

WARRANTY/DISCLAIMER

OMEGA ENGINEERING, INC. warrants this unit to be free of defects in materials and workmanship for a period of **25 months** from date of purchase. OMEGA's WARRANTY adds an additional one (1) month grace period to the normal **two (2) year product warranty** to cover handling and shipping time. This ensures that OMEGA's customers receive maximum coverage on each product.

If the unit malfunctions, it must be returned to the factory for evaluation. OMEGA's Customer Service Department will issue an Authorized Return (AR) number immediately upon phone or written request. Upon examination by OMEGA, if the unit is found to be defective, it will be repaired or replaced at no charge. OMEGA's WARRANTY does not apply to defects resulting from any action of the purchaser, including but not limited to mishandling, improper interfacing, operation outside of design limits, improper repair, or unauthorized modification. This WARRANTY is VOID if the unit shows evidence of having been tampered with or shows evidence of having been damaged as a result of excessive corrosion; or current, heat, moisture or vibration; improper specification; misapplication; misuse or other operating conditions outside of OMEGA's control. Components in which wear is not warranted, include but are not limited to contact points, fuses, and triacs.

OMEGA is pleased to offer suggestions on the use of its various products. However, OMEGA neither assumes responsibility for any omissions or errors nor assumes liability for any damages that result from the use of its products in accordance with information provided by OMEGA, either verbal or written. OMEGA warrants only that the parts manufactured by the company will be as specified and free of defects. OMEGA MAKES NO OTHER WARRANTIES OR REPRESENTATIONS OF ANY KIND WHATSOEVER, EXPRESSED OR IMPLIED, EXCEPT THAT OF TITLE, AND ALL IMPLIED WARRANTIES INCLUDING ANY WARRANTY OF MERCHANTABILITY AND FITNESS FOR A PARTICULAR PURPOSE ARE HEREBY DISCLAIMED. LIMITATION OF LIABILITY: The remedies of purchaser set forth herein are exclusive, and the total liability of OMEGA with respect to this order, whether based on contract, warranty, negligence, indemnification, strict liability or otherwise, shall not exceed the purchase price of the component upon which liability is based. In no event shall OMEGA be liable for consequential, incidental or special damages.

CONDITIONS: Equipment sold by OMEGA is not intended to be used, nor shall it be used: (1) as a "Basic Component" under 10 CFR 21 (NRC), used in or with any nuclear installation or activity; or (2) in medical applications or used on humans. Should any Product(s) be used in or with any nuclear installation or activity, medical application, used on humans, or misused in any way, OMEGA assumes no responsibility as set forth in our basic WARRANTY/DISCLAIMER language, and, additionally, purchaser will indemnify OMEGA and hold OMEGA harmless from any liability or damage whatsoever arising out of the use of the Product(s) in such a manner.

RETURN REQUESTS/INQUIRIES

Direct all warranty and repair requests/inquiries to the OMEGA Customer Service Department. BEFORE RETURNING ANY PRODUCT(S) TO OMEGA, PURCHASER MUST OBTAIN AN AUTHORIZED RETURN (AR) NUMBER FROM OMEGA'S CUSTOMER SERVICE DEPARTMENT (IN ORDER TO AVOID PROCESSING DELAYS). The assigned AR number should then be marked on the outside of the return package and on any correspondence. The purchaser is responsible for shipping charges, freight, insurance and proper packaging to prevent breakage in transit.

FOR **WARRANTY** RETURNS, please have the following information available BEFORE contacting OMEGA:

1. Purchase Order number under which the product was PURCHASED,
2. Model and serial number of the product under warranty, and
3. Repair instructions and/or specific problems relative to the product.

FOR **NON-WARRANTY** REPAIRS, consult OMEGA for current repair charges. Have the following information available BEFORE contacting OMEGA:

1. Purchase Order number to cover the COST of the repair,
2. Model and serial number of the product, and
3. Repair instructions and/or specific problems relative to the product.

OMEGA's policy is to make running changes, not model changes, whenever an improvement is possible. This affords our customers the latest in technology and engineering. OMEGA is a registered trademark of OMEGA ENGINEERING, INC.

© Copyright 2006 OMEGA ENGINEERING, INC. All rights reserved. This document may not be copied, photocopied, reproduced, translated, or reduced to any electronic medium or machine-readable form, in whole or in part, without the prior written consent of OMEGA ENGINEERING, INC.

Where Do I Find Everything I Need for Process Measurement and Control? **OMEGA...Of Course!** *Shop online at omega.com*

TEMPERATURE

- ☑ Thermocouple, RTD & Thermistor Probes, Connectors, Panels & Assemblies
- ☑ Wire: Thermocouple, RTD & Thermistor
- ☑ Calibrators & Ice Point References
- ☑ Recorders, Controllers & Process Monitors
- ☑ Infrared Pyrometers

PRESSURE, STRAIN AND FORCE

- ☑ Transducers & Strain Gages
- ☑ Load Cells & Pressure Gages
- ☑ Displacement Transducers
- ☑ Instrumentation & Accessories

FLOW/LEVEL

- ☑ Rotameters, Gas Mass Flowmeters & Flow Computers
- ☑ Air Velocity Indicators
- ☑ Turbine/Paddlewheel Systems
- ☑ Totalizers & Batch Controllers

pH/CONDUCTIVITY

- ☑ pH Electrodes, Testers & Accessories
- ☑ Benchtop/Laboratory Meters
- ☑ Controllers, Calibrators, Simulators & Pumps
- ☑ Industrial pH & Conductivity Equipment

DATA ACQUISITION

- ☑ Data Acquisition & Engineering Software
- ☑ Communications-Based Acquisition Systems
- ☑ Plug-in Cards for Apple, IBM & Compatibles
- ☑ Datalogging Systems
- ☑ Recorders, Printers & Plotters

HEATERS

- ☑ Heating Cable
- ☑ Cartridge & Strip Heaters
- ☑ Immersion & Band Heaters
- ☑ Flexible Heaters
- ☑ Laboratory Heaters

ENVIRONMENTAL MONITORING AND CONTROL

- ☑ Metering & Control Instrumentation
- ☑ Refractometers
- ☑ Pumps & Tubing
- ☑ Air, Soil & Water Monitors
- ☑ Industrial Water & Wastewater Treatment
- ☑ pH, Conductivity & Dissolved Oxygen Instruments