

User's Guide



Shop online at

omega.com[®]
OMEGA[®]

omega.com

e-mail: info@omega.com

*For latest product manuals:
omegamanual.info*



TRCN442
Turbidity Analyzer



OMEGAnet® Online Service
omega.com

Internet e-mail
info@omega.com

Servicing North America:

U.S.A.:
ISO 9001 Certified
One Omega Drive, P.O. Box 4047
Stamford, CT 06907-0047
TEL: (203) 359-1660
FAX: (203) 359-7700
e-mail: info@omega.com

Canada:
976 Bergar
Laval (Quebec) H7L 5A1, Canada
TEL: (514) 856-6928
FAX: (514) 856-6886
e-mail: info@omega.ca

For immediate technical or application assistance:

U.S.A. and Canada: Sales Service: 1-800-826-6342/1-800-TC-OMEGA®
Customer Service: 1-800-622-2378/1-800-622-BEST®
Engineering Service: 1-800-872-9436/1-800-USA-WHEN®

Mexico:
En Español: (001) 203-359-7803
e-mail: espanol@omega.com
FAX: (001) 203-359-7807
info@omega.com.mx

Servicing Europe:

Czech Republic: Frystatska 184, 733 01 Karviná, Czech Republic
TEL: +420 (0)59 6311899
FAX: +420 (0)59 6311114
Toll Free: 0800-1-66342
e-mail: info@omegashop.cz

Germany/Austria: Daimlerstrasse 26, D-75392 Deckerpfronn, Germany
TEL: +49 (0)7056 9398-0
FAX: +49 (0)7056 9398-29
Toll Free in Germany: 0800 639 7678
e-mail: info@omega.de

United Kingdom:
ISO 9002 Certified
One Omega Drive, River Bend Technology Centre
Northbank, Irlam, Manchester
M44 5BD United Kingdom
TEL: +44 (0)161 777 6611
FAX: +44 (0)161 777 6622
Toll Free in United Kingdom: 0800-488-488
e-mail: sales@omega.co.uk

It is the policy of OMEGA Engineering, Inc. to comply with all worldwide safety and EMC/EMI regulations that apply. OMEGA is constantly pursuing certification of its products to the European New Approach Directives. OMEGA will add the CE mark to every appropriate device upon certification.

The information contained in this document is believed to be correct, but OMEGA accepts no liability for any errors it contains, and reserves the right to alter specifications without notice.

WARNING: These products are not designed for use in, and should not be used for, human applications.

Instruction Manual

Turbidity Meter

TRCN442

Index

| | |
|---|----|
| Specifications | 3 |
| Mechanical Description | 4 |
| Turbidity Measurement Principle | 5 |
| Dimensional | 7 |
| Equipment Installation | 8 |
| Interconnection Barr | 9 |
| Electrical Schematic | 10 |
| Lens & Bubble Trap Cleaning | 11 |
| Calibration Information | 12 |
| Turbidity Standards | 13 |
| Equipment Operation | 14 |
| Equipment Operation - Turning On | 15 |
| Equipment Opeartion - Set Up | 16 |
| Equipment Operation - Calibration | 20 |
| Equipment Operation - Read | 21 |
| Communication Protocol | 22 |

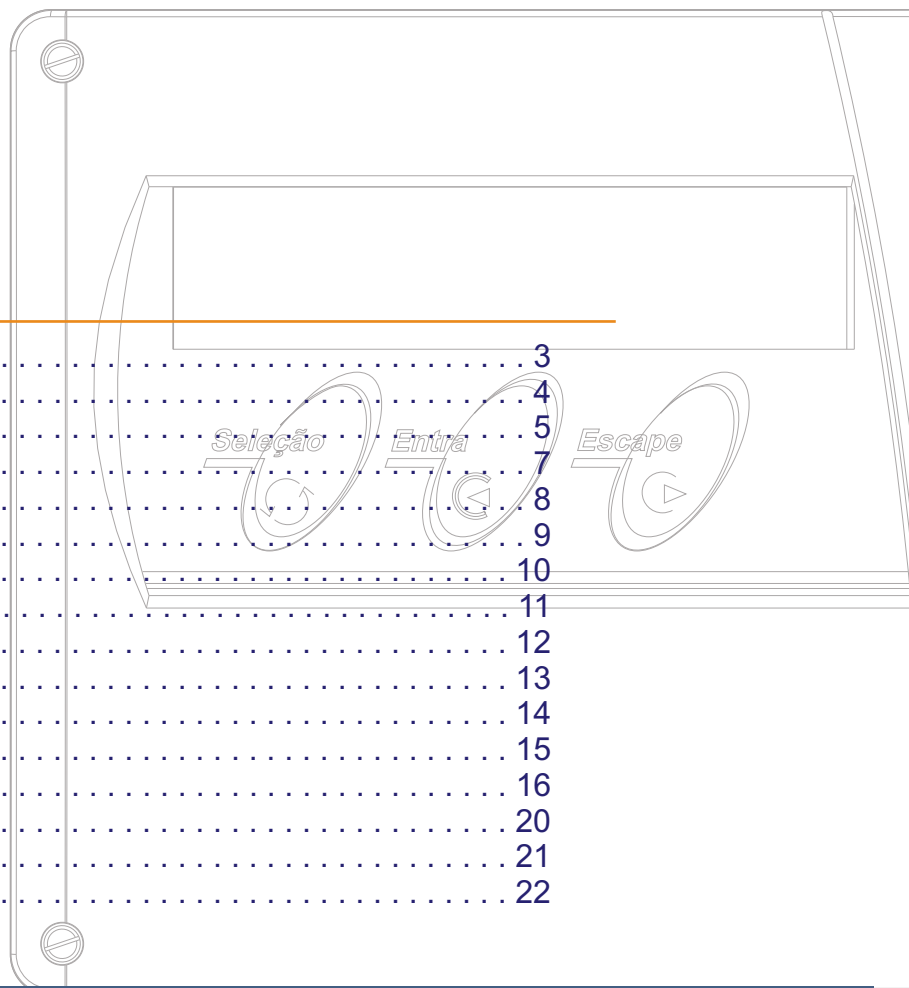

2. Specifications

| | |
|--------------------------------|--|
| APPLICATION | Analyzer / Transmitter / Turbidity Controller |
| ANALYZER | |
| Display | Alphanumeric 2 lines x 16 characters |
| Range | 0.01 to 20 / 20.1 to 100 NTU |
| Resolution | 0.01 / 0.1 |
| Relative Precision | 0.01% (full scale) |
| Analytical Method | Nephelometric |
| Wavelength | 525 nm |
| GENERAL | |
| Enclosure | IP-68 |
| Body Material | Cast Aluminum SAE 323(BASE) ABS (Frontal Lid) |
| Electrical Connection | Terminal Barr |
| Cable Inlet | Cable Knockout 3/8" BSP (4x) |
| Installation | Flat Surface |
| Relative Humidity | 20 to 80 % |
| Electrical Power | 90 to 240 VAC (50/60 Hz) |
| Power Consumption | 3.5 VA |
| Sample Flow | 250 to 750 ml/min |
| Sample Pressure (Min./max.) | 10 / 20 psi |
| Sample Temperature | 5 to 40°C |
| Weight | 5 Kg (equipment and bubble trapper) |
| TRANSMITTER | |
| Analogic Output | 2x 4 to 20 mA |
| Digital Output | RS-485 |
| CONTROLLER | |
| Type ON-OFF / PWM | Two,NO (1A / 250 VAC) |
| Set-Point | from 0 to 100% of scale |
| ACCESSORIES | |
| Instruction Manual | |
| Installation Hardware | 2 aluminum base SAE 323, 2 "U" clamps in SS 316, Nuts and washers in SS 316 |

3. Mechanical Description

The equipment is offered in a compact cast aluminum case, **SAE-323** with lower oxidation power, treated against corrosion, finished with epoxy-electrostatic paint and expanded polypropylene panels (PU). With reduced dimensions and very light weight, is build under **IP-67** protection.

Under the same case, user will find: Local Indicator, Analyzer, Transmitter and Controller of ease operation. The control installation can be done on Flat Surface or on 2" tube.

The electrical connection is made by a terminal block located at the lower portion of the controller and cables will go thru 4 cable knockouts of 3/8" BSP.



PARTS DESCRIPTION:

- 1 - Frontal Lid in ABS
- 2 - Alphanumeric Display 2 lines x 16 characters
- 3 - 3 keys tactile membrane:
 - <SELECT> = Selects the desired option, flashing option.
 - <ENTER> = Confirms the selected option chosen at SELECT key
 - <ESCAPE> = Goes back one step or moves back to prior screen
- 4 - Cable knockouts (4x) of 3/8" BSP for instrumentation and power cables
- 5 - Sensor / Turbidity Detector
- 6 - Bubble Trapper (to remove bubbles)
- 7 - Cleaning Drainage
- 8 - Sample Inlet Connection
- 9 - Sample Drainage

4. Turbidity Measurement Principles

TURBIDITY MEASUREMENT

The measured **Turbidity** of determined sample, is the reading referred by light dispersed and absorption that goes thru the sample.

Turbidity does not mean suspended solids measurement, but a effect determination of light refracted through solids.

Turbidity measurements are used to evaluate the quantity of water sample. To understand turbidity it is helpful to think about the characteristics of mixtures.

A mixture is defined as **Homogenous** or **Monophasic**, when the components of the mixture are uniformly dispersed, or dissolved, throughout the mixture, Salt water is an example of a homogenous mixture or **Solution**. **Heterogenous** or **Polyphasic** mixtures are those whose components are not well distributed throughout the mixture. The components may simple be floating in the mixture, given enough time these components will settle out. This type of mixture is also called **Suspension**.

The clarity of a water sample is directly related to the amount of material suspended in the water. Turbidity measurements are a way to measure the amount of material suspended in a water sample. They are commonly used to monitor the effectiveness of filtration processes.

The OMEGA Turbidity meter uses the principle of Nephelometry. As light of a known intensity is passed through a sample some of the light will be scattered by particles in the sample. A detector is placed at 90° to the sample to collect the scattered light. The intensity of the scattered light is compared to that of the source. This value is reported as a Nephelometric Turbidity Unit, or NTU. The meter is calibrated with Formazine standards of a known NTU.

Water can sometimes have color of its own (from humic sources, for example). This color may interfere with the light source, absorbing some of the light, and reducing the amount of light reaching the detector. This can cause the measurement to be skewed. The OMEGA Turbidity Meter LED light source emits at a range close to infrared. In this range absorption is minimized, and turbidity measurements are more accurate.

4. Turbidity Measurement Principles (cont.)

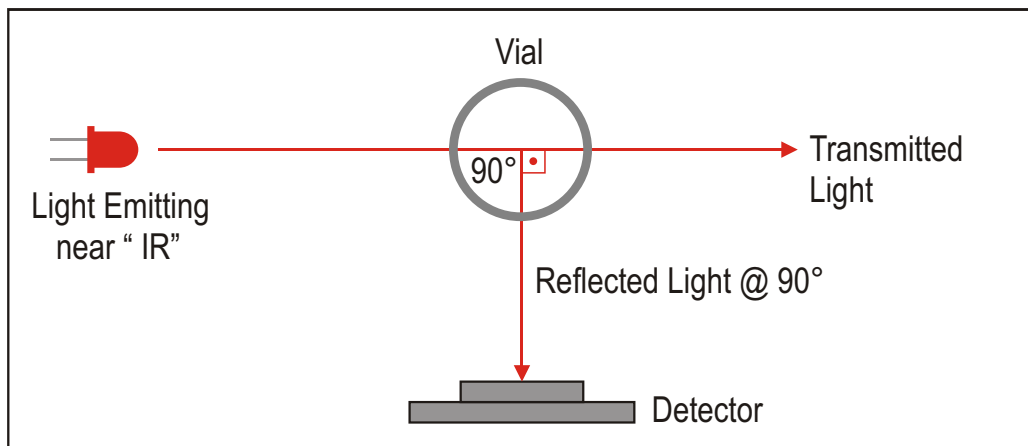

As detection involves the difference between the light reaching the vial and transmitted by the sample placed at the cuvette, it is convenient to minimize the effects that diminish the light intensity transmitted, among those the most important, it is the absorption caused by the samples color.

Because of this it is essential to work in a light wavelength where absorption would be minimum (close to infrared), if we work in a electromagnetic spectrum visible region, this color interference would certainly alter the results.

In order to quantify the turbidity, we can use many comparison standards, being NTU (Nephelometric Turbidity Unit) scale the most common, patronized from formazine standard suspensions. This way we would have a comparison standard scale between different materials, in a way we can evaluate turbidity with precision.

[Bibliographic References](#)

[Bela G. Lipták \(chief editor\) Analytical Instrumentation;](#)

[Howard A. Strobel and William R. Heineman, Chemical Instrumentation, A Systematic Approach.](#)

5. Dimensional

Below you will find panel dimensional for installation in flat surface and distances between support holes.

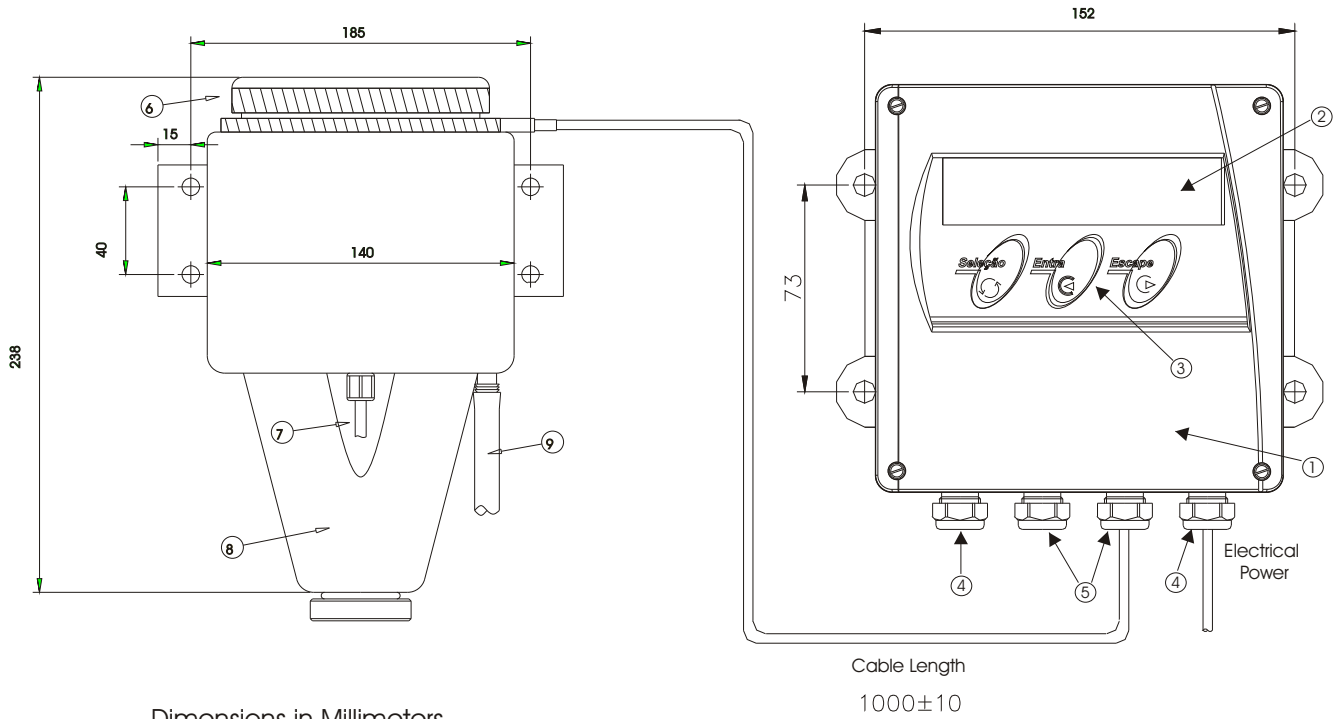

Dimensions in Millimeters

| ITEM | DESCRIPTION |
|------|---|
| 9 | Hose 1/2" Drainage |
| 8 | Bubble Trapper (remove bubbles) in Black PP |
| 7 | PU Hose - Diam. 6x1mm (Sample Inlet) |
| 6 | Turbidity Sensor / Detector |
| 5 | Cable Knockout 3/8" (2x) |
| 4 | Cable Knockout 3/8" (2x) |
| 3 | PU Tactile Membrane |
| 2 | Alphanumeric Display 2lines x 16characters |
| 1 | Frontal Lid in Resin |

6. Equipment Installation

Follow rigorously below instructions:

- 1- Remove the equipment from its box and verify for any possible damages, caused by the transportation.
- 2- Install the controller in a strategic place, of ease access and operation, free of vibrations and vapors.
- 3- Avoid direct exposure of the controller to solar rays and in case if necessary, protect the controller.
- 4- Proceed with terminal connections of cables at terminal barr.
- 5- Inspect the electrical installation in order to certify that all connections are correct.
- 6- Verify the power that is being supplied and make sure to connect it the proper place.
- 7- Connect the circuit breakers from the power distribution box.

3.1. Important Recommendations

3.1.1. The equipment **Electrical Power** must be **independent** from other system components. Being so, the power cable of Control Valves, Solenoids, Alarms, etc, must be connected directly at the Distribution Box, and "**never**" at the equipment connection board.

3.1.2. **Verify** if the equipment **cable knockouts** are providing the proper sealing to the cable inlets. This proceeding is a must in order to preserve enclosure as IP-67.

3.1.3. **Be careful with Humidity!!**. It reduces impedance, generating measuring errors. Verify the cable knockout and if necessary, **dry the connection block** using a hair dryer.

3.1.4. **Do not cut or try to attach the connection cable**. In case you need to change its length, Contact OMEGA Customer Service.

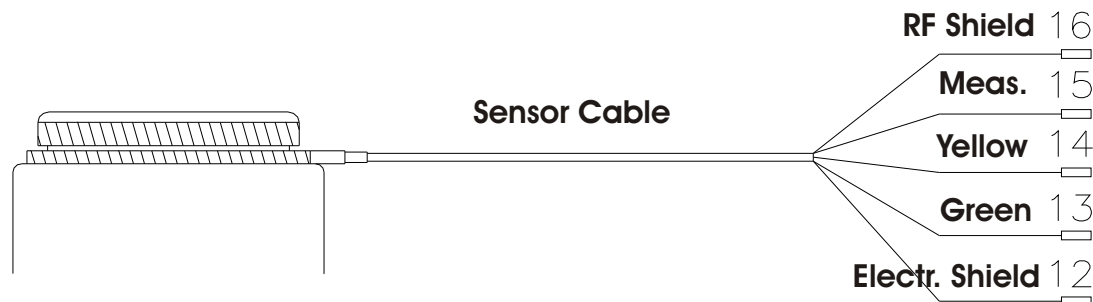

3.1.5. ON-OFF **outputs** are **thyristor** type, offering innumerous advantages for the equipment, such as: no presence of sparks, faster commutation, noise practically un-existent, no presence of RF interference and many more.

The outputs can commute any charge, since they are **powered by alternate tension (VAC)**, **limited to 250V / 1A**.

7. Interconnection Barr

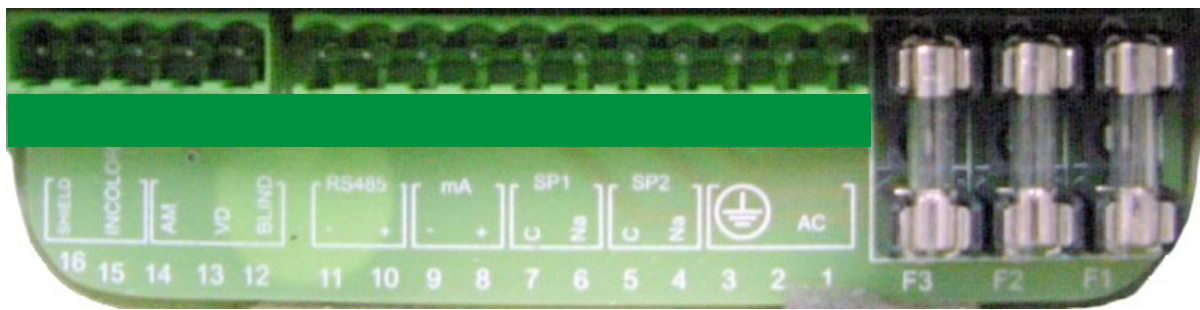

CN2 - Connector 2

Slots

1 and 2

3

4 and 5

6 and 7

8 and 9

10 and 11

CN1 - Connector 1

12

13

14

15

16

FUSES

F1

F2

F3

Connection

Electrical Power for 90/240 Vac 50/60Hz connection

Ground

SP2 - Set-Point 2 for alarm or control

SP1 - Set-Point 1 for alarm or control

Digital Transmission Output 4 to 20 mA

Serial Communication Output - RS485

Turbidity Sensor Cable Shield

Green

Yellow

Measure (Colorless)

Turbidity Sensor Cable Shield

General Fuse (3.0A)

Set-Point 2 Fuse (1.0 A)

Set-Point 1 Fuse (1.0A)

8. Electrical Schematic

Note: It's very important to use phases and cables for Equipments and valves.

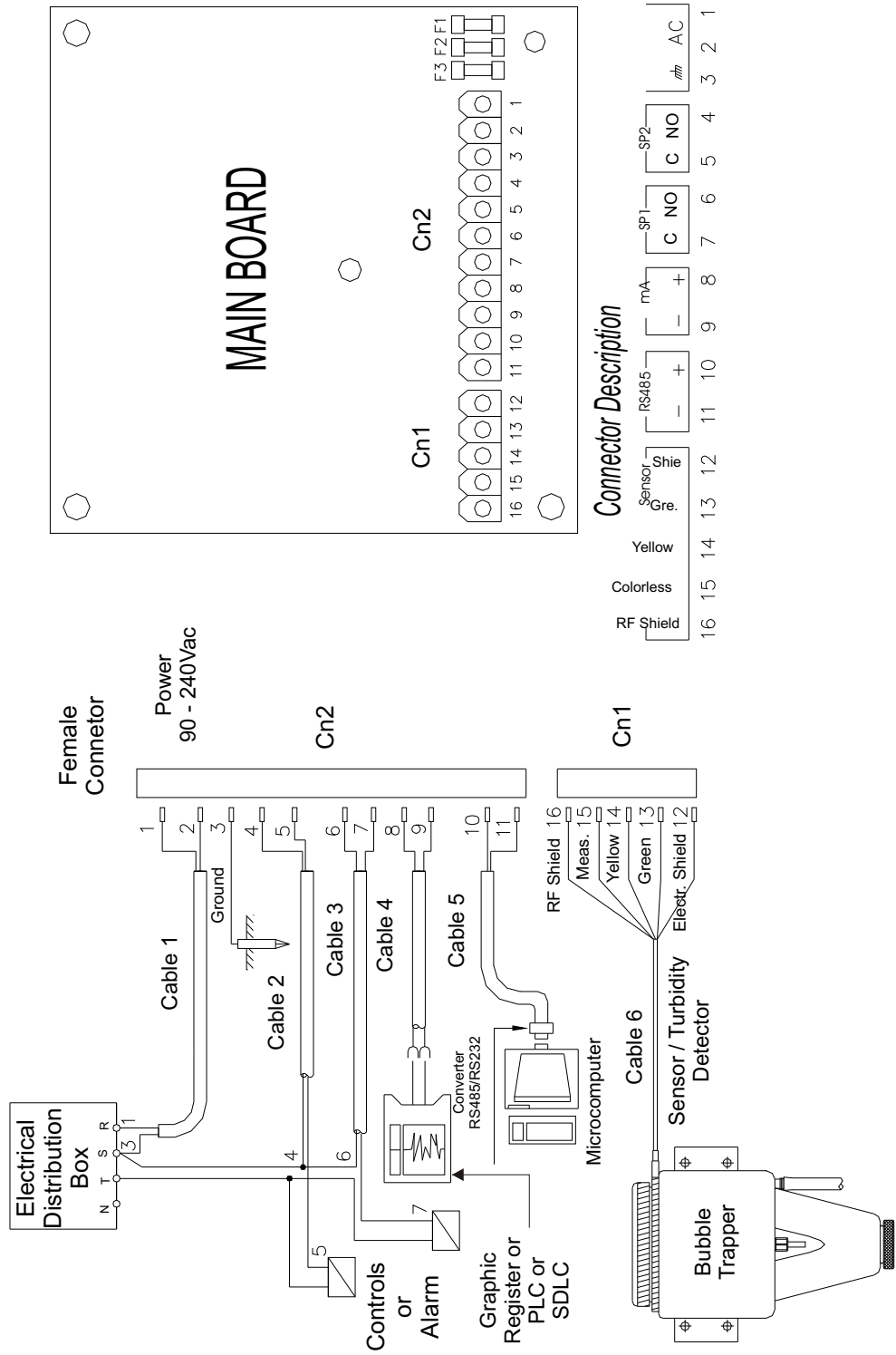

9. Lens and Bubble Trap Cleaning

Sensor Unit Lens and Bubble Trapper Cleaning

LENS CLEANING OF SENSOR UNIT

Remove the Sensor/Turbidity Detector (5) by turning it clockwise (45degrees) and pull it up. Using a soft sponge and neutral soap, wash the Led and the photocell Lenses. After this, dry it using a soft Absorbent paper, a type that will not leave residues.

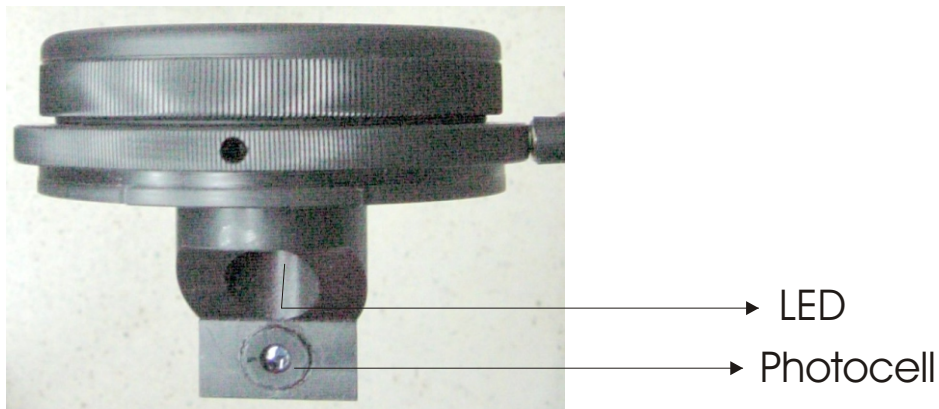

BUBBLE TRAPPER CLEANING

Clean the Bubble Trapper. Un-thread the Drainage Lid, so the sample can be drained from the instrument and the bubble trapper removed. Wash it using neutral soap and dry it using a soft absorbent paper, a type that will not leave residues. Make sure to look for areas where residues can accumulate (shown below picture). Remove the Bubble trapper as shown below and after cleaning make sure to put it back in place!



10. Calibration Information

- 1) Prepare the following standards: (Distilled Water, H₂O deionized, filtered twice using 20 microns filters 0.120 NTU). Only filter if your deionized water is not from a reliable source!
- 2) Clean the Calibration Reservoir.
- 3) Place the Standards inside the calibration reservoir until it overflows some milliliters, as shown at below picture. Place the Sensor Unit Lid in place, wait a few seconds; then place the equipment under calibration mode.
- 4) Repeat items 2 and 3 at every one of the 3 (three) standard change, do not forget to clean and dry The calibration reservoir without leaving any residues.

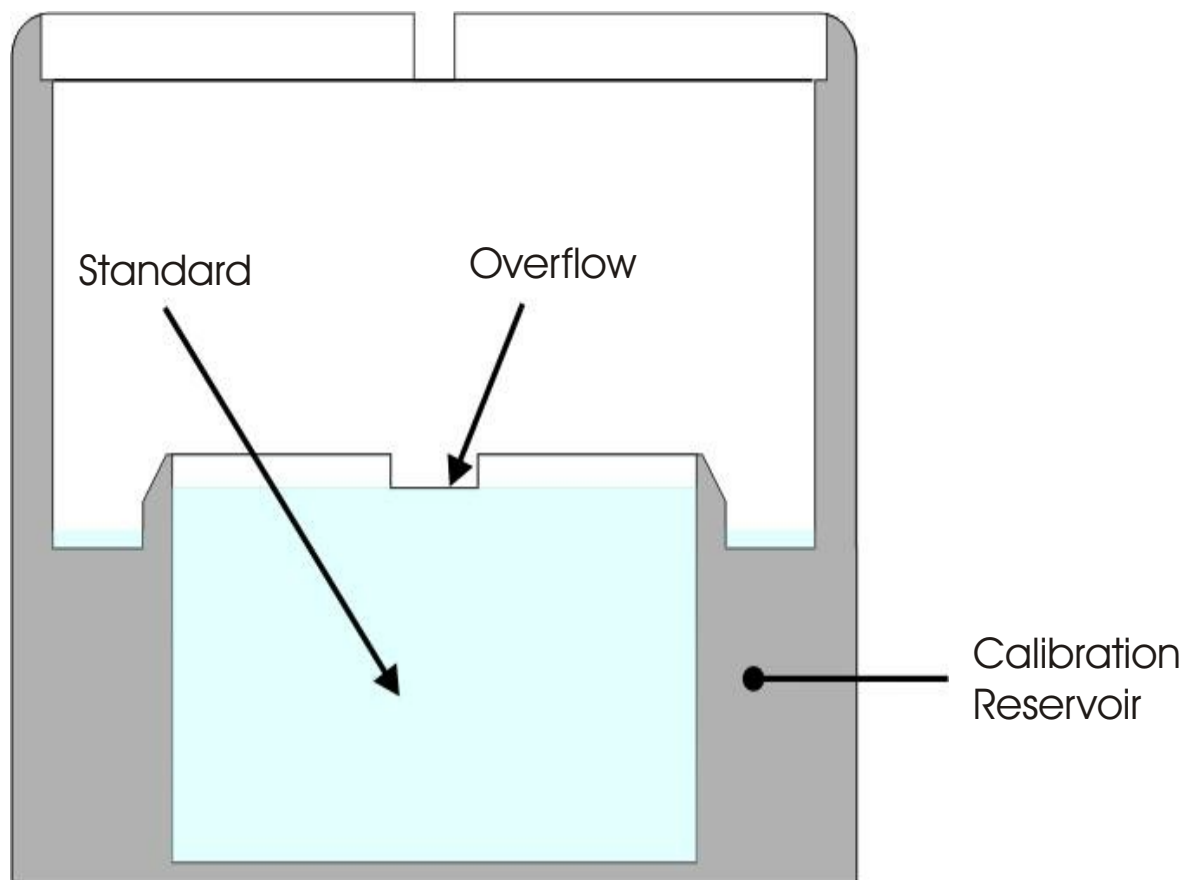

11. Turbidity Standard

Instructions on how to prepare Calibration Solutions

1. Standard Zero

In order to obtain a turbidity close to Zero, use a good quality deionized or distilled water and filter it twice in a roll, using a 0.2 μm filter and teorically you will obtain a water with 0.12NTU, that can be considered Zero (Blank).

Note: this water will be used to dilute the standard.

2. Standard Solutions

The instrument is not supplied with a 100mL bottle of 1000NTU Stabilized Standard Solution, model# TRS-444, for dilution and calibration purpose. The Formazine should be ordered separate!

1 - Necessary Materials:

- 1.1 - 1 Volumetric Flask 100 mL
- 1 Volumetric Pipette 50 mL
- 2 L Distilled or Deionized Water, Filtered (0.2 μm)

2 - Calibration Solution 500 NTU

- 2.1 - In a 100ml Volumetric Flask, using the Volumetric Pipette add 50ml of 1000NTU Stabilized Standard Solution.
- 2.2 - Add filtered water up to the mark on the flask.
- 2.3 - Before using the solution mix it by gently inverting the flask several times. Avoid creating bubbles.
- 2.4 - The Solution is Valid for 15 days.

Note: For best storage conditions place the solution in a dark bottle and store it in a fresh and dark place.

3 - Calibration Solution 100 NTU

- 3.1 - In a 100ml Volumetric Flask, using the Volumetric Pipette add 10ml of 1000NTU Stabilized Standard Solution.
- 3.2 - Add filtered water up to the mark on the flask.
- 3.3 - Before using the solution mix it by gently inverting the flask several times. Avoid creating bubbles.
- 3.4 - The Solution is Valid for 10 days.
- 3.5 - After its use, discharge the solution.

Note: For best storage conditions place the solution in a dark bottle and store it in a fresh and dark place.

4 - Calibration Solution 10 NTU

- 4.1 - In a 100ml Volumetric Flask, using the Volumetric Pipette add 1ml of 1000NTU Stabilized Standard Solution.
- 4.2 - Add filtered water up to the mark on the flask.
- 4.3 - Before using the solution mix it by gently inverting the flask several times. Avoid creating bubbles.
- 4.4 - Stir it manually for before using it.
- 4.4 - The Solution is Valid for 5 days.
- 4.5 - After its use, discharge the solution.

Note: For best storage conditions place the solution in a dark bottle and store it in a fresh and dark Place.

Attention: for TURBIDITY, this instrument MUST BE calibrated using Formazine Standard and cannot be calibrated using Polymers!!!

12. Equipment Operation

Set Up Procedures

The equipment offers a non-volatile memory (**E2PROM**), in order to store operations functions (resolution, reading, Calibration and more). Even when turned off from power, all functions chosen during set up will remain stored.

Before starting any work with the equipment, it is recommended to **verify the SET UP parameters**, to certify that you have chosen the correct options for the operation .

When at the **SELECT FUNCTION** menu, press **<SEL>** key in order to select the desired function, flashing option, then press **<ENT>** key. In order to access the **SET UP**, press **<SEL>** key until SET function flashes, then press **<ENT>** key to confirm the option chosen. A Password will be requested, press in sequence **<SEL>**, **<ENT>**, **<ESC>** then follow step by step the options shown at the screen. In case the user desires to change the flashing option, press **<SEL>** key until the desired option flashes then press **<ENT>** key to confirm the option. In order to move to the next screen, user must press **<ENT>** key .

Read Operation

At this operation user will have options to **CALIBRATE** and **READ**. In case the desire is to **CALIBRATE** the Sensor, press **<SEL>** key until **Cal** option flashes, then press **<ENT>** key to confirm the option chosen. From this point on the program will guide the user step by step on how to proceed with the perfect calibration. In case the desire is to Read, press **<SEL>** key until option **Read** flashes, then press **<ENT>** key to confirm, then the display show the following form:

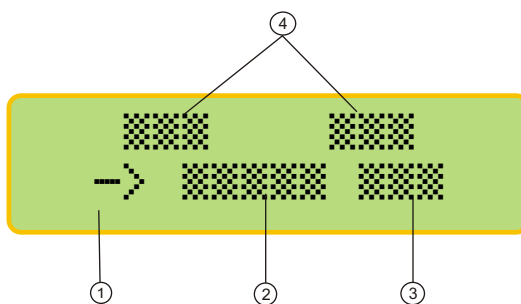

- 1- The "**Prompt**" is a signal that flashes every time a reading is performed.
- 2- The measured value
- 3- The Unit (NTU)
- 4- Contact Outputs Conditions

12. Equipment Operation - Turning On

T menus are self explanatory with its respective options, that are simply selected by pressing **<SELECT>** key. After choosing the selection (flashing option), press **<ENTER>** key, to confirm the selected option.

If a mistake occur or user desires to change option already chosen, press **<ESCAPE>**, to go back to prior step. At every touch the screen will move back one step back. While in Reading Mode, **<ESCAPE>** key must be pressed and hold for about 6 seconds to exit this mode and return to main menu.

Interpreting the Read menu. The Set Points will be displayed and by the box on the side of each contact, user can find out the status of these contacts.

■ Indicates that the contact is On and operating at the moment.

□ Indicates that the contact is On but not operating at the moment.

☒ Indicates that this contact was set as Off

All contacts are programmed during Set Up Mode.

Press **<ESC>** key and hold in order to exit the Reading Mode and access the Main Menu.

OMEGA
MOD: TRCN442 U1.0

DISPLAY TEST

XXXXXXXXXXXXXXXXXXXX
XXXXXXXXXXXXXXXXXXXX

S1:☒ S2:☒
-> 0.001 NTU

TURBIDIMETER
READ/SET UP

NOTE:

While during Reading, press **<ENTER>** key and the instrument will go to **STAND-BY**, turning off the alarm and control outputs.

Note A - Every time you see the symbols “>” and “<”, that means that the user can adjust the displayed value up or down.

To increase the value press **<SEL>** key until “>” flashes, then press **<ENT>** to confirm, then press **<SEL>** key and at every touch the value will increase by one unit.

To decrease the value press **<SEL>** key until “<” flashes, then press **<ENT>** to confirm, then press **<SEL>** key and at every touch the value will decrease by one unit.

If a mistake is made, press **<ESC>** key to return and correct the value!

12. Equipment Operation - Set Up

Press **<SEL>** until **Set Up** flashes then press **<ENT>** key.

A Password is required in order to access the **SET UP**. Press in sequence **<SEL>**, **<ENT>** and **<ESC>**

In order to select the desired language, press **<SEL>** key until the desired option flashes, then press **<ENT>** key to confirm.

User can program the instrument, such as Default Calibration, On Line Calibration and more. If chosen **No**, the last configuration will remain in effect. Press **<SEL>** key until the desired option flashes, then press **<ENT>** Key to confirm .

The Range cannot be changed. It is default from

You can calibrate the instrument as factory default. Choose **Yes** and confirm and the instrument will calibrate as factory default! This option is offered in case the user does have any other way to perform a calibration procedure.

The user will be allowed to adjust the Turbidity value read at sample. Press **<SEL>** until **MAN** flashes then confirm by pressing **<ENT>**.

User will be able to choose the number of calibration Points. Press **<SEL>** key until the desired option flashes and confirmed by pressing **<ENT>**.

User will be able to adjust the value of the calibration points chosen. Refer to page 16 (Note A) for instructions on how adjust this value.

User can choose between the following Reading Modes:
Continuous - Read continuously after time is set
Average - Reads the average after time is set
User can program the time between Readings for Average Reading.
Refer to Page 16 (Note A) for instructions on how to adjust this time.

TURBIDIMETER
READ/SET UP

PASSWORD

LANG.: PORT./
ENGLISH/SPANISH

CONFIG. INSTR.?
YES / NO

RANGE
0 - 1000 NTU

FACTORY DEFAULT?
YES / NO

CONFIRM?
YES / NO

ON LINE CAL.:
MANUAL / AUTO

CAL. POINTS:
1 / 2 / 3

CALIBRATION
Pt.1 10.00NTU<>

CALIBRATION
Pt.2 20.0NTU<>

READING MODE:
CONTIN./AVER.

TIME BETWEEN
READINGS: 5s <>

A Go to Page 17

A
Go to Page 17

12. Equipment Operation - Set Up (cont.)

User can program the display to show information like Barr graph, Clock and more.

User can choose if desire to have Barr graph shown above the Reading screen. When Bar Graph is displayed, the information about Sensibility and Sample Temperature will not be displayed!
User can now adjust the Minimum and Maximum values for the Bar Graph. Refer to Page 16 (Note A) for instructions on how to modify these values.

User has the option to configure Contacts SP 1and SP 2. Press **<SELECT>** key to choose the desired option then press **<ENTER>** key to confirm.

If user chooses Contact S1 as On, while at Reading Mode, a or a will be displayed after the S1, indicating that this Contact is On. If user chooses Contact S1 as Off, while at Reading Mode, a will be

User can adjust the value for SP 1.
Refer to Page 16 (Note A) for instruction on how to adjust this value. Resolution will depend upon the Resolution chosen while at Set Up.

User can choose the Acting desired.
Press **<SELECT>** key to choose the desired option then press **<ENTER>** key to confirm

User can adjust the value for Hystereses.
Refer to Page 16 (note A)for instruction on how to adjust this value. Resolution will depend upon the Resolution chosen while at Set Up.

For the Burn Out configuration, user will have three options as:
On - Contact is going to stay On all the time, Off - contact will stay Off all the time or Hold - contact is going to follow the last situation, before going to Hold status.
Press **<SEL>** key until the desired option flashes, then press **<ENT>** to confirm.

If user chooses Contact S2 as On, while at Reading Mode, a or a will be displayed after the S1, indicating that this Contact is On. If user chooses Contact S1 as Off, while at Reading Mode, a will be

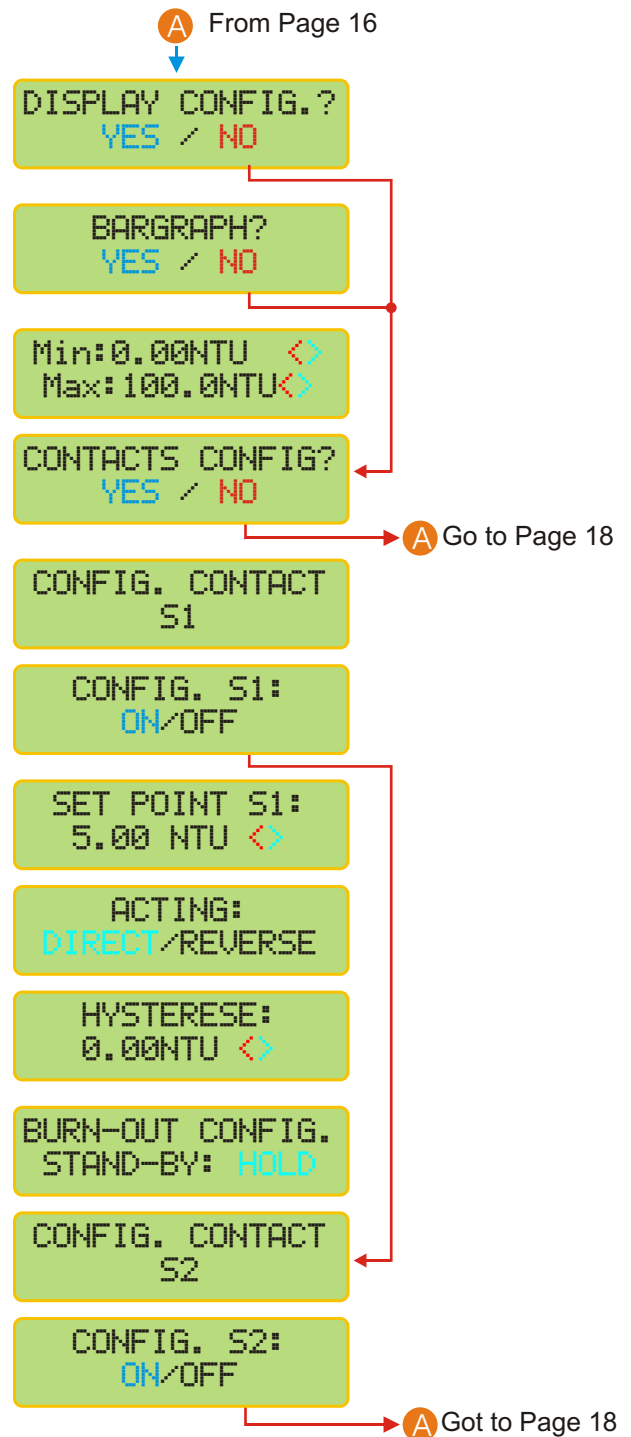

12. Equipment Operation - Set Up (cont.)

User can adjust the value for SP 2.
Refer to Page 16 (Note A) for instruction on how to adjust this value. Resolution will depend upon the Resolution chosen while at Set Up.

User can choose the Acting desired.
Press **<SELECT>** key to choose the desired option then press **<ENTER>** key to confirm

User can adjust the value for Hystereses.
Refer to Page 16 (note A) for instruction on how to adjust this value. Resolution will depend upon the Resolution chosen while at Set Up.

For the Burn Out configuration, user will have three options as: On - Contact is going to stay On all the time, Off - contact will stay Off all the time or Hold - contact is going to follow the last situation, before going to Hold status.
Press **<SEL>** key until the desired option flashes, then press **<ENT>** to confirm.

User has the option to configure Current.
Press **<SELECT>** key to choose the desired option then press **<ENTER>** key to confirm.

User has the option to choose using Output mA.
Press **<SELECT>** key to choose the desired option then press **<ENTER>** key to confirm.

User can adjust the value the values for 4 and 20mA Current Output.
Refer to Page 16 (Note A) for instruction on how to adjust this value. Resolution will depend upon the Resolution chosen while at Set Up.

For the Burn Out configuration, user will have three options as: 4mA, 20mA or Hold.
Press **<SEL>** key until the desired option flashes, then press **<ENT>** to confirm.

User will be able to calibrate mA output.
Press **<SELECT>** key to choose the desired option then press **<ENTER>** key to confirm

Connect Amp Meter to output 4-20mA and it will be possible to adjust them, then press **<ENTER>** when ready.
Adjust the value as needed by pressing **<SELECT>** (to decrease) or **<ESCAPE>** (to increase) keys, so the outputs can be adjusted.
<SELECT> key will decrease the value and **<ESCAPE>** key will increase.

SET POINT S2:
20.00 NTU <>

ACTING:
DIRECT/REVERSE

HYSTERESE:
0.00NTU <>

BURN-OUT CONFIG:
STAND-BY: HOLD

CURRENT CONFIG.? ← A From Page 17
YES / NO

OUTPUT CONFIG.:
mA

MA OUTPUT:
ON/OFF

VALUE FOR 4 mA
0.00NTU <>

VALUE FOR 20 mA
5.00NTU <>

BURN-OUT CONFIG:
STAND-BY: 4mA

CALIBRATE mA?
YES / NO

CONFIRM?
YES / NO

PLACE AMP METER
@ OUTPUT 4-20 mA

READY?

ADJUST 4 mA
<SEL>- <ESC>+

ADJUST 20 mA
<SEL>- <ESC>+

← A From Page 17

→ Go to Page 19

12. Equipment Operation - Set Up (cont.)

User will have the option to configure digital output RS-485 for Proprietary or Modbus Protocol. Press **<SELECT>** key to choose the desired option then press **<ENTER>** key to confirm .

User will be able to define the instrument identification number within the network, up to 32 instruments. Refer to Page 13 for instruction on how to adjust this value. This output is for Proprietary Protocol Communication with Speed (9600), No Parity, Bit 8 and Stop Bit 1. Refer to Page 22.

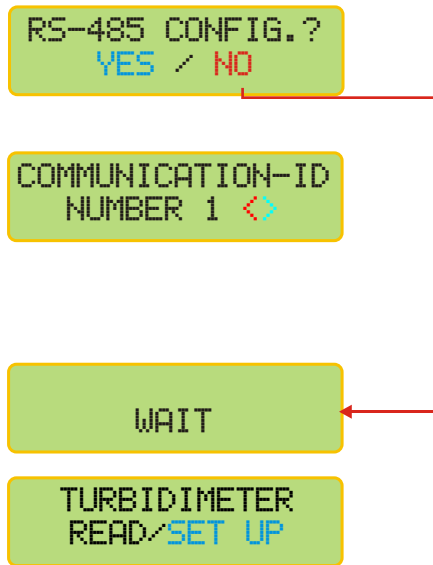

12. Equipment Operation - Calibration

Before initiating the Calibration Procedure, prepare the Standard Solutions and have the deionized water ready. Also clean the Calibration Reservoir using deionized water at every change of Standard Solution.

Press **<SEL>** until **Read** flashes then press **<ENT>** key.

Press **<SEL>** until **Calibrate** flashes then press **<ENT>** key.

Follow instructions as per page 13, dip the Standard Solution on the value shown, this Std Solution is chosen during Set Up Mode. Press **<SEL>** until desired option flashes then press **<ENT>** key. User will still have the option to accept this calibration point or not! Press **<ENT>** key to confirm.

Place the sensor unit, as per instruction on page 13, into the Standard value shown. This Std Solution is chosen during Set Up Mode. Press **<SEL>** until desired option flashes then press **<ENT>** key.

Press **<ENT>** key to confirm.

The equipment will analyze the Standard Solution and if it does not match the instrument linearity, it will inform the user about its quality, but if the user decides to use this solution, he will be able to do so!

Follow instructions as per page 13, dip the Standard Solution on the value shown, this Std Solution is chosen during Set Up Mode. Press **<SEL>** until desired option flashes then press **<ENT>** key. User will still have the option to accept this calibration point or not! Press **<ENT>** key to confirm.

Place the sensor unit, as per instruction on page 13, into the Standard value shown. This Std Solution is chosen during Set Up Mode. Press **<SEL>** until desired option flashes then press **<ENT>** key.

Press **<ENT>** key to confirm.

Remove the sensor from the bubble trapper, remove the Calibration cup. Re-insert the sensor into the trapper, open the process and proceed with Readings.

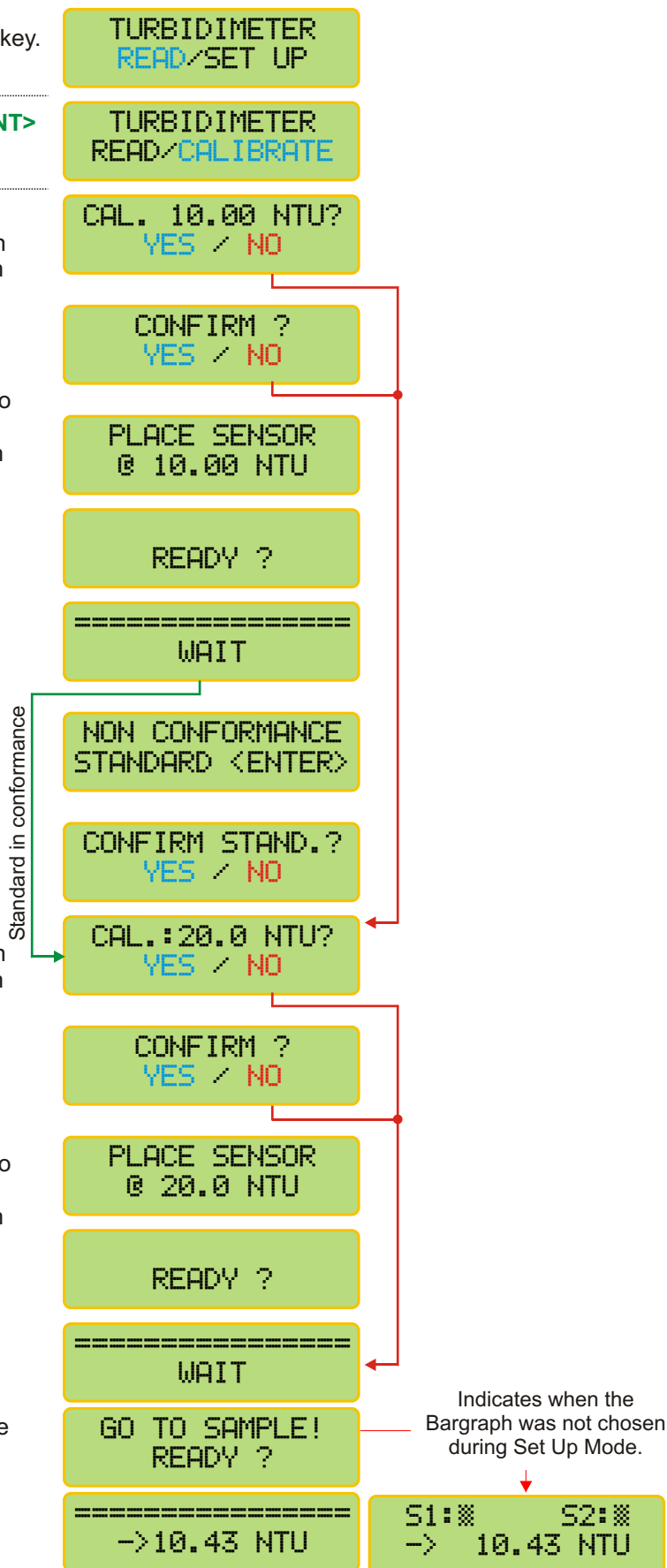

12. Equipment Operation - Read

Find below instructions on how to perform a Turbidity Reading. Before starting, verify if the bubble trapper is clean, if the drain hose is connected and "open" and if the sample is flowing correctly. Finally insert the sensor unit at the bubble trapper and lock it by turning it counter clockwise (45degrees).

Press **<SEL>** until **Read** flashes then press **<ENT>** key.

```
TURBIDIMETER
READ/SET UP
```

Press **<SEL>** until **Read** flashes then press **<ENT>** key.

```
TURBIDIMETER
READ/CALIBRATE
```

Verify if sample is flowing and drain hose is connected, then press **<ENT>** key to start Reading Mode.

```
GO TO SAMPLE!
READY?
```

Indicates when the Bargraph was not chosen during Set Up Mode.

Press **<ENT>** key to place the equipment in Stand By.

```
=====
-> 10.00 NTU
```

```
S1:⌘ S2:⌘
-> 10.00 NTU
```

Press **<ENT>** key to exit Stand By and return to Read Mode.

```
STAND BY
```

Press **<SEL>** key to verify the Contact and Current conditions.

```
=====
-> 10.00 NTU
```

```
S1:⌘ S2:⌘
-> 4.83 mA
```

Press **<SEL>** and it will be able to adjust the value Read, if chosen this procedure during Set Up Mode (On Line Calibration-page 17). Refer to page 16 (Note A) for instructions on how to adjust this value.

```
ON LINE CALIBR.
10.00 NTU <>
```

In order to exist the reading Mode, press and hold **<ESC>** key. User will then access the main menu.

```
=====
-> 10.50 NTU
```

```
TURBIDIMETER
READ/SET UP
```

13. Proprietary Communication Protocol

Communication Protocol (TRCN442):

1) Proprietary:

Order:

| | | | | | |
|------|----|------|------|------|-------------|
| ESC | ID | P | CR | LF | |
| 0x1B | | 0x50 | 0x0D | 0x0A | Hexadecimal |

The ID is configured at the instrument from 1 to 32.

Answer:

L > > VVVVVV **NTU** CCCCCC **m A**

Example of answer for an *un-stable* value

L > 0.05 **NTU** 1 2 . 0 0 **m A**

Example of answer for a *stable* value

L > > 0 . 0 5 **NTU** 1 2 . 0 0 **m A**

Note: a) When the answer comes a C instead of a L, it means that the equipment is under calibration function (is being operated in location by the user, executing the calibration operation at the instrument).

b) When the answer comes an S instead of a L, it means that the equipment is under Set Up function and it is being operated in location by the user.

2) RS485 – It is a “physical location”, where the proprietary protocol will be “transported”.

As factory default, this communication comes configured as:

Speed = 9600

Parity = none

Number of Bits = 8

Stop Bit = 1

ID = 1

WARRANTY/DISCLAIMER

OMEGA ENGINEERING, INC. warrants this unit to be free of defects in materials and workmanship for a period of **13 months** from date of purchase. OMEGA's WARRANTY adds an additional one (1) month grace period to the normal **one (1) year product warranty** to cover handling and shipping time. This ensures that OMEGA's customers receive maximum coverage on each product.

If the unit malfunctions, it must be returned to the factory for evaluation. OMEGA's Customer Service Department will issue an Authorized Return (AR) number immediately upon phone or written request. Upon examination by OMEGA, if the unit is found to be defective, it will be repaired or replaced at no charge. OMEGA's WARRANTY does not apply to defects resulting from any action of the purchaser, including but not limited to mishandling, improper interfacing, operation outside of design limits, improper repair, or unauthorized modification. This WARRANTY is VOID if the unit shows evidence of having been tampered with or shows evidence of having been damaged as a result of excessive corrosion; or current, heat, moisture or vibration; improper specification; misapplication; misuse or other operating conditions outside of OMEGA's control. Components in which wear is not warranted, include but are not limited to contact points, fuses, and triacs.

OMEGA is pleased to offer suggestions on the use of its various products. However, OMEGA neither assumes responsibility for any omissions or errors nor assumes liability for any damages that result from the use of its products in accordance with information provided by OMEGA, either verbal or written. OMEGA warrants only that the parts manufactured by the company will be as specified and free of defects. OMEGA MAKES NO OTHER WARRANTIES OR REPRESENTATIONS OF ANY KIND WHATSOEVER, EXPRESSED OR IMPLIED, EXCEPT THAT OF TITLE, AND ALL IMPLIED WARRANTIES INCLUDING ANY WARRANTY OF MERCHANTABILITY AND FITNESS FOR A PARTICULAR PURPOSE ARE HEREBY DISCLAIMED. LIMITATION OF LIABILITY: The remedies of purchaser set forth herein are exclusive, and the total liability of OMEGA with respect to this order, whether based on contract, warranty, negligence, indemnification, strict liability or otherwise, shall not exceed the purchase price of the component upon which liability is based. In no event shall OMEGA be liable for consequential, incidental or special damages.

CONDITIONS: Equipment sold by OMEGA is not intended to be used, nor shall it be used: (1) as a "Basic Component" under 10 CFR 21 (NRC), used in or with any nuclear installation or activity; or (2) in medical applications or used on humans. Should any Product(s) be used in or with any nuclear installation or activity, medical application, used on humans, or misused in any way, OMEGA assumes no responsibility as set forth in our basic WARRANTY/DISCLAIMER language, and, additionally, purchaser will indemnify OMEGA and hold OMEGA harmless from any liability or damage whatsoever arising out of the use of the Product(s) in such a manner.

RETURN REQUESTS/INQUIRIES

Direct all warranty and repair requests/inquiries to the OMEGA Customer Service Department. BEFORE RETURNING ANY PRODUCT(S) TO OMEGA, PURCHASER MUST OBTAIN AN AUTHORIZED RETURN (AR) NUMBER FROM OMEGA'S CUSTOMER SERVICE DEPARTMENT (IN ORDER TO AVOID PROCESSING DELAYS). The assigned AR number should then be marked on the outside of the return package and on any correspondence.

The purchaser is responsible for shipping charges, freight, insurance and proper packaging to prevent breakage in transit.

FOR **WARRANTY** RETURNS, please have the following information available BEFORE contacting OMEGA:

1. Purchase Order number under which the product was PURCHASED,
2. Model and serial number of the product under warranty, and
3. Repair instructions and/or specific problems relative to the product.

FOR **NON-WARRANTY** REPAIRS, consult OMEGA for current repair charges. Have the following information available BEFORE contacting OMEGA:

1. Purchase Order number to cover the COST of the repair,
2. Model and serial number of the product, and
3. Repair instructions and/or specific problems relative to the product.

OMEGA's policy is to make running changes, not model changes, whenever an improvement is possible. This affords our customers the latest in technology and engineering.

OMEGA is a registered trademark of OMEGA ENGINEERING, INC.

© Copyright 2007 OMEGA ENGINEERING, INC. All rights reserved. This document may not be copied, photocopied, reproduced, translated, or reduced to any electronic medium or machine-readable form, in whole or in part, without the prior written consent of OMEGA ENGINEERING, INC.

Where Do I Find Everything I Need for Process Measurement and Control? **OMEGA...Of Course!** *Shop online at omega.com*

TEMPERATURE

- Thermocouple, RTD & Thermistor Probes, Connectors, Panels & Assemblies
- Wire: Thermocouple, RTD & Thermistor
- Calibrators & Ice Point References
- Recorders, Controllers & Process Monitors
- Infrared Pyrometers

PRESSURE, STRAIN AND FORCE

- Transducers & Strain Gages
- Load Cells & Pressure Gages
- Displacement Transducers
- Instrumentation & Accessories

FLOW/LEVEL

- Rotameters, Gas Mass Flowmeters & Flow Computers
- Air Velocity Indicators
- Turbine/Paddlewheel Systems
- Totalizers & Batch Controllers

pH/CONDUCTIVITY

- pH Electrodes, Testers & Accessories
- Benchtop/Laboratory Meters
- Controllers, Calibrators, Simulators & Pumps
- Industrial pH & Conductivity Equipment

DATA ACQUISITION

- Data Acquisition & Engineering Software
- Communications-Based Acquisition Systems
- Plug-in Cards for Apple, IBM & Compatibles
- Datalogging Systems
- Recorders, Printers & Plotters

HEATERS

- Heating Cable
- Cartridge & Strip Heaters
- Immersion & Band Heaters
- Flexible Heaters
- Laboratory Heaters

ENVIRONMENTAL MONITORING AND CONTROL

- Metering & Control Instrumentation
- Refractometers
- Pumps & Tubing
- Air, Soil & Water Monitors
- Industrial Water & Wastewater Treatment
- pH, Conductivity & Dissolved Oxygen Instruments