

**Where Do I Find Everything I Need for
Process Measurement and Control?
OMEGA...Of Course!
Shop online at omega.com**

TEMPERATURE

- ✓ Thermocouple, RTD & Thermistor Probes, Connectors, Panels & Assemblies
- ✓ Wire, Thermocouple, RTD & Thermistor
- ✓ Calibrators & Ice Point References
- ✓ Recorders, Controllers & Process Monitors
- ✓ Infrared Pyrometers

PRESSURE, STRAIN AND FORCE

- ✓ Transducers & Strain Gauges
- ✓ Load Cells & Pressure Gauges
- ✓ Displacement Transducers
- ✓ Instrumentation & Accessories

FLOW/LEVEL

- ✓ Rotameters, Gas Mass Flowmeters & Flow Computers
- ✓ Air Velocity Indicators
- ✓ Turbine/Paddlewheel Systems
- ✓ Totalizers & Batch Controllers

pH/CONDUCTIVITY

- ✓ pH Electrodes, Testers & Accessories
- ✓ Benchtop Laboratory Meters
- ✓ Controllers, Calibrators, Simulators & Pumps
- ✓ Industrial pH & Conductivity Equipment

DATA ACQUISITION

- ✓ Data Acquisition & Engineering Software
- ✓ Communications-Based Acquisition Systems
- ✓ Plug-in Cards for Apple, IBM & Compatibles
- ✓ Datalogging Systems
- ✓ Recorders, Printers & Plotters

HEATERS

- ✓ Heating Cable
- ✓ Cartridge & Strip Heaters
- ✓ Immersion & Band Heaters
- ✓ Flexible Heaters
- ✓ Laboratory Heaters

**ENVIRONMENTAL
MONITORING AND CONTROL**

- ✓ Metering & Control Instrumentation
- ✓ Refractometers
- ✓ Pumps & Tubing
- ✓ Air, Soil & Water Monitors
- ✓ Industrial Water & Wastewater Treatment
- ✓ pH, Conductivity & Dissolved Oxygen Instruments

MI-4464 (08/07)

User's Guide



http://www.omega.com
e-mail: info@omega.com

**LVU100 Series
Two-Wire Ultrasonic Level Transmitter**

OMEGA ENGINEERING, INC. warrants this unit to be free of defects in materials and workmanship for a period of **12 months** from date of purchase. OMEGA Warranty adds an additional one (1) year period to the normal **one (1) year product warranty** to cover handling and shipping time. This ensures that OMEGA's customers receive maximum coverage on each product.

If the unit should malfunction, it must be returned to the factory for evaluation. OMEGA's Customer Service Department will issue an Authorized Return (AR) number immediately upon phone or written request. Upon examination by OMEGA, if the unit is found to be defective it will be repaired or replaced at no charge. OMEGA's WARRANTY does not apply to detectors resulting from any action of the purchaser, including but not limited to handling, improper re-arranging, operation outside of design limits, improper repair or modification. This WARRANTY is VOID if the unit shows evidence of having been tampered with or shows evidence of being damaged as a result of excessive corrosion, or current, heat, moisture or vibration. Component specifications, misapplication, misuse or other operating conditions outside of OMEGA's control. Components which wear are not warranted, including but not limited to contact points, bases, and traces.

OMEGA is pleased to offer suggestions on the use of its various products. However, OMEGA neither assumes responsibility for any omissions or errors nor assumes liability for any damages that result from the use of its products in accordance with information provided by OMEGA, orally, verbally or written. OMEGA MAKES NO OTHER WARRANTIES OR REPRESENTATIONS OF ANY KIND WHATSOEVER, EXCEPT THAT OF TITLE, AND ALL IMPLIED WARRANTIES INCLUDING ANY WARRANTY OF MERCHANTABILITY AND FITNESS FOR A PARTICULAR PURPOSE ARE HEREBY DISCLAIMED. LIMITATION OF LIABILITY: The remedies of purchaser set forth herein are exclusive and the total liability of OMEGA with respect to this order, whether based on contract, warranty, negligence, misapplication, error or otherwise, shall not exceed the purchase price of the component upon which liability is based. In no event shall OMEGA be liable for consequential, incidental or special damages.

CONDITIONS: Equipment sold by OMEGA is not intended to be used, nor shall it be used: (1) as a medical application or used on humans. Should any Product(s) be used in or with any nuclear installation or activity, the purchaser is responsible for shipping charges, freight, insurance and proper packaging to prevent damage in transit.

FOR WARRANTY RETURNS, please have the following information available BEFORE contacting OMEGA:

1. PO number under which the product was PURCHASED.
2. Model and serial number of the product under repair.
3. Model and serial number of product, and Repair instructions and/or specific problems relative to the product.

OMEGA's policy is to make running changes, not model changes, whenever an improvement is possible in a product relative to the product.

OMEGA is a registered trademark of OMEGA ENGINEERING, INC. All rights reserved. This document may not be copied, reproduced, stored, transmitted or used in any electronic medium or machine-readable form in whole or in part without prior written consent of OMEGA ENGINEERING, INC.

WARRANTY/DISCLAIMER

For immediate technical or application assistance:

USA: One Omega Drive, Box 4047 Stamford, CT 06907-0047 Tel: (203) 359-1660 Fax: (203) 359-7700 E-mail: info@omega.com 976 Bengel Laval (Quebec) H7L 5A1 Tel: (514) 856-0928 Fax: (514) 856-0966 email: canada@omega.ca	Canada:
Servicing North America:	
USA and Canada: Sales Service: 1-800-826-6342 / 1-800-TC-OMEGA Customer Service: 1-800-622-2378 / 1-800-USA-WHEN Engineering Service: 1-800-272-9436 / 1-800-USA-WHEN	Mexico: En Español: (001) 203-359-7803 E-mail: espa@omega.com Fax: (001) 203-359-7807 info@omega.mx
Servicing Europe:	
Czech Republic: Přesbyska 14, 251 01 Klatovy, Czech Republic Tel: +420 019 6311114 Fax: +420 0800 1 66342 E-mail: info@omega.cz	Germany/Austria: Bühnenweg 26, D-75392 Eickemfrenn, Germany Tel: +49 07196 9386 29 Fax: +49 07196 9386 29 E-mail: info@omega.de
United Kingdom: One Omega Drive, Riverbank Technology Centre Northwich, Cheshire, Minsbury Tel: +44 (0)1829 2226611 Fax: +44 (0)1829 2226622 Tel: Free in England: 0800-488-488 E-mail: sales@omega.co.uk	

OMEGA.net - On-Line Service: http://www.omega.com
Internet e-mail: info@omega.com



OMEGA is constantly pursuing certification of its products to the European New Approach Directives. OMEGA will add the CE mark to every appropriate device upon certification.

The information contained in this document is deemed to be correct by Omega Engineering, Inc. Omega Engineering, Inc. accepts no liability for any errors or omissions and reserves the right to alter specifications without notice.

WARNING: These products are not designed for use in and should not be used by persons convicted of felonies.

SPECIFICATIONS

Step One

Range:	LVU104: 2" to 4.0' (5 cm to 1.2 m) LVU109: 4" to 9.8' (10 cm to 3m) LVU116: 4" to 16.4' (10 cm to 5m) LVU126: 8" to 26.2' (20 cm to 8m)
Accuracy:	LVU104: 0.125" (3 mm) LVU109/116/126: ± 0.2% of span in air
Resolution:	LVU104/109: 0.019" (0.5 mm) LVU116/126: 0.039" (1 mm)
Beam width:	LVU104/109: 2" (5 cm) dia. LVU116/126: 3" (7.6 cm) dia.
Dead band:	LVU104: 2" (5 cm) LVU109/116: 4" (10 cm) LVU126: 8" (20 cm)
LED indication:	Power, calibration and diagnostics
Memory:	Non-volatile
Supply voltage:	12 to 28 VDC
Loop resist.:	500 Ohms @ 24 VDC
Signal output:	4-20 mA, two-wire
Signal invert:	4-20 mA or 20-4 mA
Calibration:	Target, calibration wire
Fail-safety:	Reverts to 22 mA
Process temp.:	F: -4° to 140° / C: -20° to 60°
Temp. comp.:	Automatic
Electronics temp.:	F: -40° to 160° / C: -40° to 71°
Pressure:	30 psi (2 bar) @ 25° C., derated @ 0.857 psi (.057 bar) per °C. above 25° C.
Enclosure rating:	Optional - NEMA 6 (IP67) Optional - NEMA 4X (IP65)
Encl. material:	PC/ABS FR
Trans. material:	PVDF
Cable jacket mat.:	PP
Cable type:	3-conductor, shielded
Cable length:	10' (3m)
Conduit entrance:	Optional - Dual, 1/2" NPT
Process mount:	LVU104/109: 1" NPT (1" G) LVU116/126: 2" NPT (2" G)
Mount. gasket:	Viton®
Classification:	General purpose
CE compliance:	EN 61326 EMC

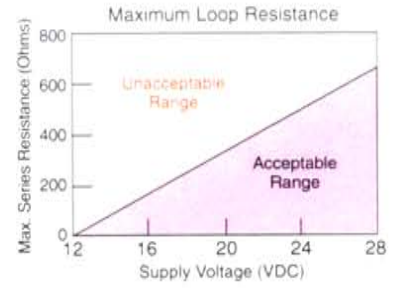
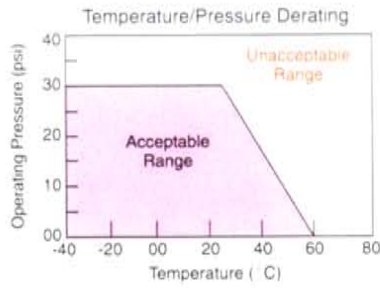

Standard NEMA 6 Enclosure Top View

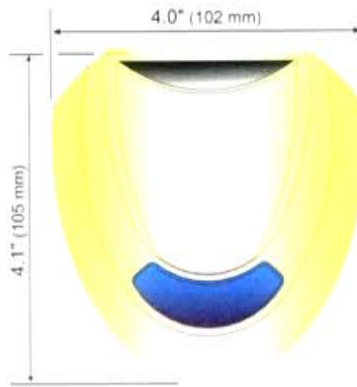

Optional NEMA 4X Enclosure Top View

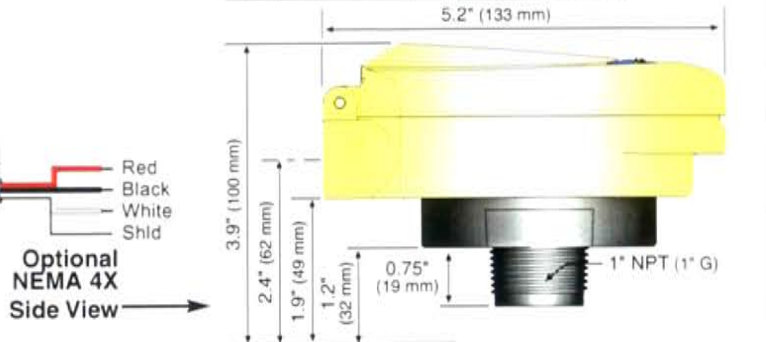
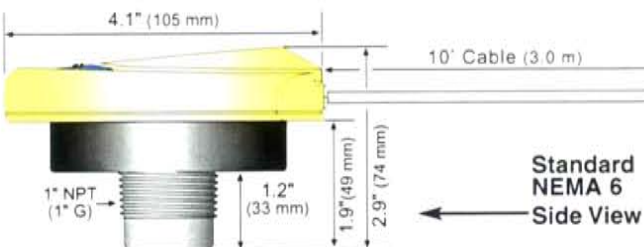
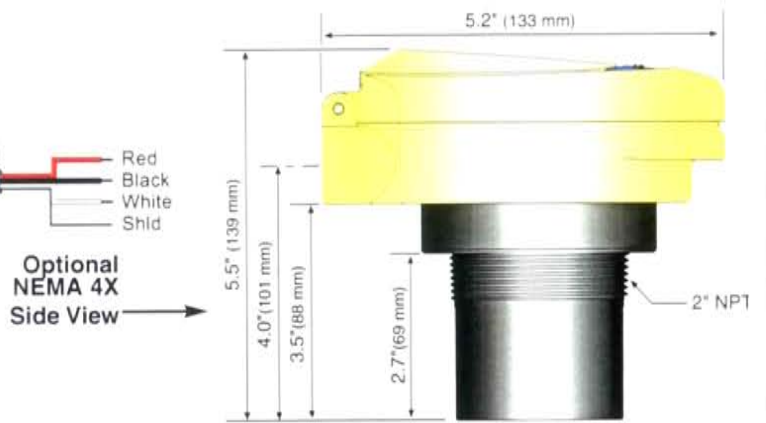
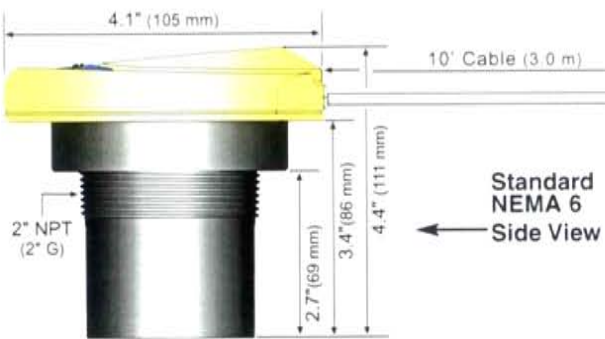
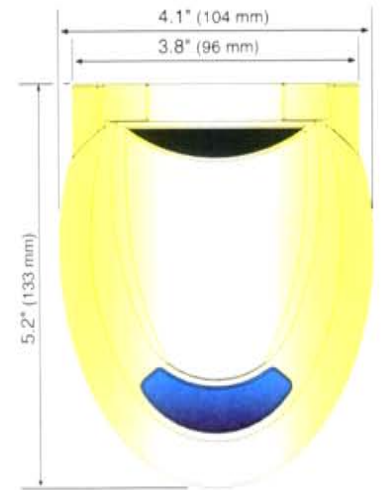

SAFETY

Step Two

⚠ About this Manual: PLEASE READ THE ENTIRE MANUAL PRIOR TO INSTALLING OR USING THIS PRODUCT. This manual includes information on the LVU100 Series Ultrasonic Level Transmitter from OMEGA. Please refer to the part number located on the transmitter label to verify the exact model configuration which you have purchased.

⚠ User's Responsibility for Safety: OMEGA manufactures a broad range of level sensing technologies. While each of these sensors is designed to operate in a wide variety of applications, it is the user's responsibility to select a sensor model that is appropriate for the application, install it properly, perform tests of the installed system, and maintain all components. The failure to do so could result in property damage or serious injury.

⚠ Proper Installation and Handling: Only properly trained staff should install and/or repair this product. Install the transmitter with the Viton gasket and never overtighten the transmitter within the fitting. Always check for leaks prior to system start-up.

⚠ Wiring and Electrical: A supply voltage of 12-28 VDC is used to power the transmitter. The sensor circuit should never exceed a maximum of 28 volts DC. Electrical wiring of the sensor should be performed in accordance with all applicable national, state, and local codes.

⚠ Material Compatibility: The enclosure is made of a flame retardant Polycarbonate (PC/ABS FR). The transducer is made of Polyvinylidene Fluoride (PVDF). Make sure that the model which you have selected is chemically compatible with the application media.

⚠ Enclosure: While the transmitter housing is liquid-resistant the LVU100 Series is not designed to be operational when immersed. It should be mounted in such a way that the enclosure and transducer do not come into contact with the application media under normal operational conditions.

⚠ Make a Fail-Safe System: Design a fail-safe system that accommodates the possibility of transmitter and/or power failure. OMEGA recommends the use of redundant backup systems and alarms in addition to the primary system.

⚠ Flammable, Explosive or Hazardous Applications: The LVU100 Series should not be used within classified hazardous environments.

⚠ Warning ⚠

Always use the Viton gasket when installing the LVU100 Series transmitter, and always connect the shield wire to the common ground.

OVERVIEW

Step Three

A. Application: The general purpose two-wire ultrasonic transmitter provides non-contact level measurement up to 26.2' or 8m, and is ideally suited for challenging corrosive, coating or waste liquids. The transmitter is broadly selected for atmospheric bulk storage, day tank, process vessel and waste sump applications. Media examples include polymer, ink and hydrochloric acid.

B. Part Number: The part and serial numbers are located on the wrench flat. Check the part number on the product label and confirm which of the below model configurations you have purchased:

Part Number	Range	Enclosure	Mount
LVU104	1.2m (4.0')	NEMA 6 (IP67)	1" NPT
LVU104G	1.2m (4.0')	NEMA 6 (IP67)	1" G
LVU104-NEMA4	1.2m (4.0')	NEMA 4X (IP65)	1" NPT
LVU104G-NEMA4	1.2m (4.0')	NEMA 4X (IP65)	1" G
LVU109	3m (9.8')	NEMA 6 (IP67)	1" NPT
LVU109G	3m (9.8')	NEMA 6 (IP67)	1" G
LVU109-NEMA4	3m (9.8')	NEMA 4X (IP65)	1" NPT
LVU109G-NEMA4	3m (9.8')	NEMA 4X (IP65)	1" G
LVU116	5m (16.4')	NEMA 6 (IP67)	2" NPT
LVU116G	5m (16.4')	NEMA 6 (IP67)	2" G
LVU116-NEMA4	5m (16.4')	NEMA 4X (IP65)	2" NPT
LVU116G-NEMA4	5m (16.4')	NEMA 4X (IP65)	2" G
LVU126	8m (26.2')	NEMA 6 (IP67)	2" NPT
LVU126G	8m (26.2')	NEMA 6 (IP67)	2" G
LVU126-NEMA4	8m (26.2')	NEMA 4X (IP65)	2" NPT
LVU126G-NEMA4	8m (26.2')	NEMA 4X (IP65)	2" G

C. NEMA 4X Enclosure: The NEMA 4X (IP65) enclosure has a flip cover with two 1/2" NPT female conduit ports and an internal terminal strip for wiring. To open the enclosure, you will need a small insertion tool such as a small screwdriver or paperclip. Insert the tool into the hole located at the front of the enclosure and gently push on the latching mechanism to release the cover. Rotate the hinged cover up for 135° access to the terminal strip. **Before closing the enclosure, make sure that the enclosure gasket is properly seated, and that any conduit fittings, cable connectors and/or plugs are installed correctly and sealed.**

Optional NEMA 4X Enclosure Shown

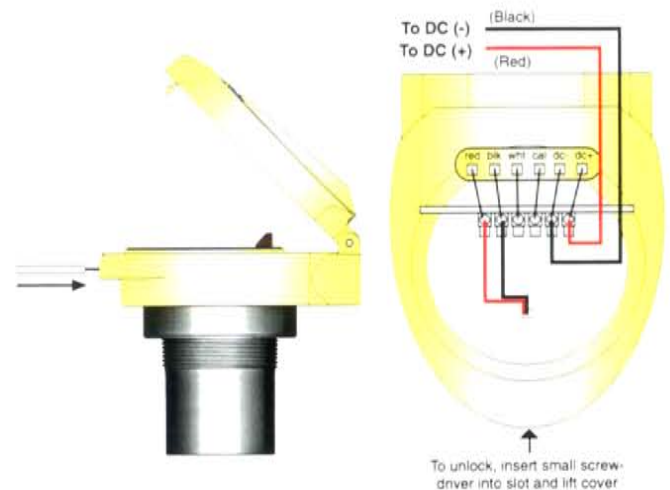

PREPARATION

Step Four

A. Supply Voltage: The transmitter power supply voltage should never exceed a maximum of 28 VDC. OMEGA controllers and meters have built-in 24 VDC power supplies for use with the transmitter. Alternative controllers and/or power supplies with a minimum output may also be used with the transmitter for calibration and/or operation.

B. Cable Length: The cable length may be extended up to a maximum of 1000 feet between the transmitter and its point of termination, using a well-insulated, shielded wire from 14 to 18 gauge.

C. Wire Stripping: Standard units with NEMA 6 enclosures are provided with a 10' cable. If necessary, use a 10 gauge wire stripper and carefully remove the outer layer of polypropylene insulation from the last 1-1/4" of the transmitters cable. Unwrap and discard the exposed foil shield from around the signal wires. With a 20 gauge wire stripper, remove the last 1/4" of the colored insulation from the signal wires.

D. Factory Span: LVU100 series are factory calibrated with 4 mA at their maximum range (tank empty) and 20 mA (tank full) at their minimum range values. The 4 and 20 mA span set points can be reverse calibrated on all models.

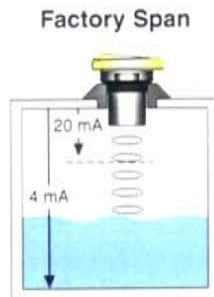

E. Maximum Applied Range: The Individual or cumulative effects of agitation, vapor or foam can reduce the overall quality of signal return and shorten the maximum applied range of the transmitter. To determine the maximum applied range of the transmitter in your application, refer to the below derating chart.

Maximum Applied Range Derating Chart

LVU104/109

Agitation = 1-3 @ 100 kHz
Vapor = 4-6 @ 100 kHz
Foam = 5-6 @ 100 kHz

LVU116/126

Agitation = 1-3 @ 50 kHz
Vapor = 3-5 @ 50 kHz
Foam = 4-6 @ 50 kHz

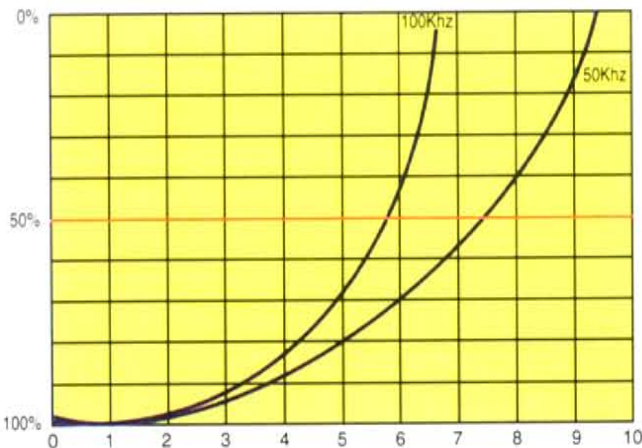

CALIBRATION

Step Five

A. Factory Settings: One option for calibration is to use the factory setting of the unit. Each version of the unit has a preset 4mA and 20 mA as seen below:

Factory Set Points			
Transmitter	4 mA Setting	20 mA Setting	Span
LVU104	4.0' (1.2m)	2" (5 cm)	46" (115 cm)
LVU109	9.8' (3m)	4" (10 cm)	114" (290 cm)
LVU116	16.4' (5m)	4" (10 cm)	193" (490 cm)
LVU126	26.2' (8m)	8" (20 cm)	307" (790 cm)

Due to advances in the electronics with the Digital Infinity transmitters, any resolution improvements are negligible when decreasing the overall operational range of the transmitter.

Version	Resolution inches (cm)
LVU104	0.019" (0.05 mm)
LVU109	0.019" (0.05 mm)
LVU116	0.039" (0.1 mm)
LVU126	0.039" (0.1 mm)

Omega recommends using the original factory settings with the transmitter and making the range adjustments in the local panel meter, display or PLC system.

B. Distance to Current Charts: Below are charts for each version of LVU100 series. The charts indicate the current at specific distances away from the transmitter. To locate the current equivalent to an empty /full tank, follow the instructions below:

1. Measure the distance from the bottom of the sensor to the bottom of the tank.
2. Locate this value under distance column for the transmitter version.
3. Select the corresponding current value from the chart. Distances not listed can be extrapolated from the next highest and lowest distances.
4. Repeat the same steps for the full tank setting.

C. Display Adjustments: Typical panel meters and displays use a 2-point method for calibration, based upon empty and full settings. Each setting will have a current reading and a corresponding value that appears on the display at that current. For example, 4 mA = 0.0 and 20.0 mA = 100.0 is a common setting. This represents a display of 0 when 4mA is applied to the sensor and 100.0 when 20 mA is applied to the sensor.

The same can be accomplished using the factory setting of the LVU100 series. For example, a LVU104 transmitter will output 8.2 mA when the level is 36" away from the transmitter (from chart). If the sensor is installed on a 36" tall tank, then the current output when the tank is empty will be 8.2 mA. When programming the display, entering 8.2 mA = 0.0 and 20.0 mA = 100.0 will have the display read between 0 to 100. This will have the resolution as calibrating the LVU104 to 4mA = 36.0 and 20mA = 2.0 and the display programmed to 4mA = 0.0 and 20 mA = 100.0. This method avoids having to calibrate the sensor and will have no effect with respect to the resolution of the unit.

CALIBRATION

Step Six

D. Conversion Chart (Nominal) for LVU104:

Distance inches	Current mA	Distance inches	Current mA	Distance inches	Current mA
02	20.0	20	13.7	40	6.8
04	19.3	24	12.3	44	5.4
08	17.9	28	11.0	48	4.0
12	16.5	32	09.6		
16	15.1	36	08.2		

Nominal Scaling Factor (2.875 inches/mA)

Distance cm	Current mA	Distance cm	Current mA	Distance cm	Current mA
05	20.0	50	13.7	100	06.8
10	19.3	60	12.3	110	05.4
20	17.9	70	11.0	120	04.0
30	16.5	80	09.6		
40	15.1	90	08.1		

Nominal Scaling Factor (7.188 cm/mA)

E. Conversion Chart (Nominal) for LVU109

Distance inches	Current mA	Distance inches	Current mA	Distance inches	Current mA
04	20.0	42	14.7	84	8.8
06	19.7	48	13.8	90	7.9
12	18.9	54	13.0	96	7.1
18	18.0	60	12.1	102	6.2
24	17.2	66	11.3	108	5.4
30	16.3	72	10.5	114	4.7
36	15.5	78	9.6	118	4.0

Nominal Scaling Factor (7.25 inches/mA)

Distance cm	Current mA	Distance cm	Current mA	Distance cm	Current mA
10	20.0	125	13.7	250	06.8
25	19.2	150	12.3	275	05.4
50	17.8	175	10.9	300	04.0
75	16.4	200	09.5		
100	15.0	225	08.1		

Nominal Scaling Factor (18.125 cm/mA)

CALIBRATION

Step Seven

F. Conversion Chart (Nominal) for LVU116:

Distance inches	Current mA	Distance inches	Current mA	Distance inches	Current mA
04	20.0	72	14.4	144	8.4
12	19.3	84	13.4	156	7.4
24	18.3	96	12.4	168	6.4
36	17.3	108	11.4	180	5.4
48	16.4	120	10.4	192	4.4
60	15.4	132	9.4	197	4.0

Nominal Scaling Factor (12.062 inches/mA)

Distance cm	Current mA	Distance cm	Current mA	Distance cm	Current mA
10	20.0	175	14.6	350	08.9
25	19.5	200	13.8	375	08.1
50	18.7	225	13.0	400	07.3
75	17.9	250	12.2	425	06.4
100	17.1	275	11.3	450	05.6
125	16.2	300	10.5	475	04.8
150	15.4	325	09.7	500	04.0

Nominal Scaling Factor (30.625 cm/mA)

G. Conversion Chart (Nominal) for LVU126:

Distance inches	Current mA	Distance inches	Current mA	Distance inches	Current mA
08	20.0	120	14.2	240	07.9
12	19.8	132	13.5	252	07.3
24	19.2	144	12.9	264	06.7
36	18.5	156	12.3	276	06.0
48	17.9	168	11.7	288	05.4
60	17.3	180	11.0	300	04.8
72	16.7	192	10.4	312	04.2
84	16.0	204	09.8	315	04.0
96	15.4	216	09.2		
108	14.8	228	08.5		

Nominal Scaling Factor (19.188 inches/mA)

Distance cm	Current mA	Distance cm	Current mA	Distance cm	Current mA
20	20.0	300	14.3	575	08.6
50	19.4	325	13.7	600	08.1
75	18.9	350	13.2	625	07.6
100	18.4	375	12.7	650	07.1
125	17.8	400	12.2	675	06.6
150	17.3	425	11.7	700	06.1
175	16.8	450	11.2	725	05.5
200	16.3	475	10.7	750	05.0
225	15.8	500	10.2	775	04.5
250	15.3	525	09.6	800	04.0
275	14.8	550	09.1		

Nominal Scaling Factor (48.75 cm/mA)

CALIBRATION

Step Eight

H. Target Calibration - Setting 4 mA or 20 mA: The second option for calibrating the LVU100 series is to change the 4mA from the factory setting to the empty tank and the 20 mA from the factory setting to the full tank. This method will require that the level of liquid be lowered to the empty level and raised to the full level. If this is not possible, the changes can be accomplished by pointing the transmitter at a wall or flat object the equivalent distances for empty and full. This method is referred to as Target Calibration.

I. Calibration Tools: To target calibrate the transmitters 4-20 mA span you will need a 12-28 VDC power supply, tape measurer, flat reflective target such as a wall, optional multimeter and Omega box insert for use as a product holder.

J. Off Tank Target Calibration: Locate a flat reflective calibration target such as a wall. Place the transmitter perpendicular to the target in the provided Omega box insert or equivalent holder. Alternatively, you may hold the transmitter with your hand, but it is critical that the product is held steady and perpendicular to the target during span calibration.

Standard Unit

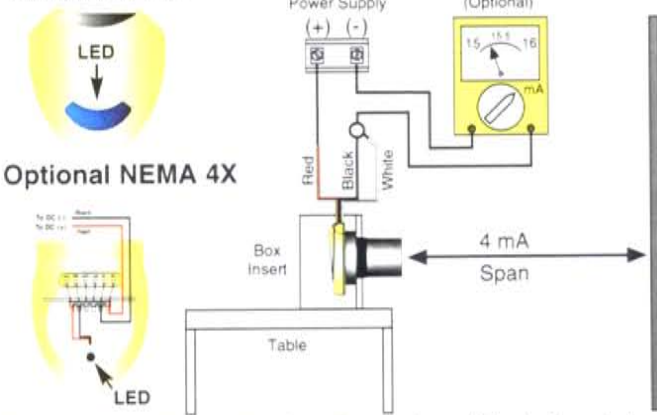

K. 4 mA Span Calibration Procedure (Tank Empty)

1. If the transmitter is wired with power ON, turn power OFF to the transmitter and wait 30 seconds before continuing.
2. Connect the the Red transmitter wire to the (+) terminal of the power supply. Connect the Black and White transmitter wires to the (-) terminal of the power supply.
3. Stretch the tape measurer out to the appropriate distance in between the transmitter and target.
4. Position the transmitter at the desired 4 mA calibration distance defined as the air gap space between the transducer and the target. **Make sure that the transmitter is stationary and perpendicular to the target before continuing.**
5. To calibrate the set point, turn power ON to the transmitter and wait for the LED to flash indicating that the set point has been accepted. Depending upon the span, this can take up to 45 seconds. If the LED does not flash within 60 seconds, check to make sure that line power is at least 14 VDC and that the transmitter and target are both stationary and perpendicular.
6. Turn power OFF to the transmitter and disconnect the White transmitter wire from (-) terminal of the power supply, leaving the Black transmitter wire attached.
7. Continue ahead to the 20 mA span calibration procedure.

CALIBRATION

Step Nine

L. 20 mA Span Calibration Procedure (Tank Full)

1. If the transmitter is wired with power ON, turn power OFF to the transmitter and wait 30 seconds before continuing.
2. Connect the the Black transmitter wire to the (-) terminal of the power supply. Connect the Red and White transmitter wires to the (+) terminal of the power supply.
3. Stretch the tape measurer out to the appropriate distance in between the transmitter and target.
4. Position the transmitter at the desired 20 mA calibration distance defined as the air gap space between the transducer and the target. **If the transmitter is installed in a flange fitting with riser, then the 20 mA calibration distance should be no less than the riser height + half the transmitter's dead band specification (ie: 4" riser + 8" dead band = 8" minimum 20 mA calibration distance). Make sure that the transmitter is stationary and perpendicular to the target before continuing.**
5. To calibrate the set point, turn power ON to the transmitter and wait for the LED to flash indicating that the set point has been accepted. Depending upon the span, this can take up to 10 seconds. If the LED does not flash within 30 seconds, check to make sure that line power is at least 12 VDC and that the transmitter and target are both stationary and perpendicular.
6. Turn power OFF to the transmitter and disconnect the White transmitter wire from (+) terminal of the power supply, leaving the Red transmitter wire attached.
7. The 4-20 mA span calibration is now complete.

Standard Unit

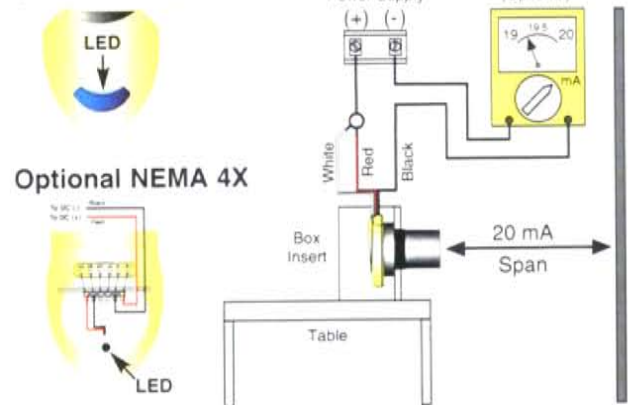

Optional NEMA 4X

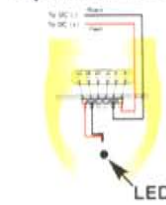

M. On Tank Target Calibration: Alternatively, the transmitter's 4-20 mA span may be target calibrated installed ON the tank by raising or lowering the liquid level to the desired 4 mA (tank empty) and 20 mA (tank full) span distances. To do so, follow the above steps #8-K and #9-M calibration procedure with the exception of moving the liquid level (versus the transmitter) in steps #8-K-4 and #9-M-4. **During calibration, make sure that the liquid is still and that there is at least some liquid in the tank for the 4 mA (tank empty) set point.**

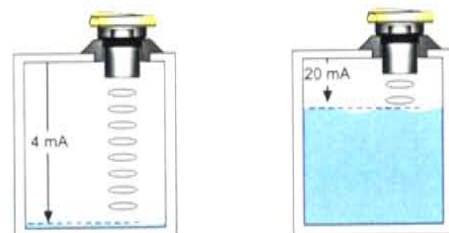

INSTALLATION

Step Ten

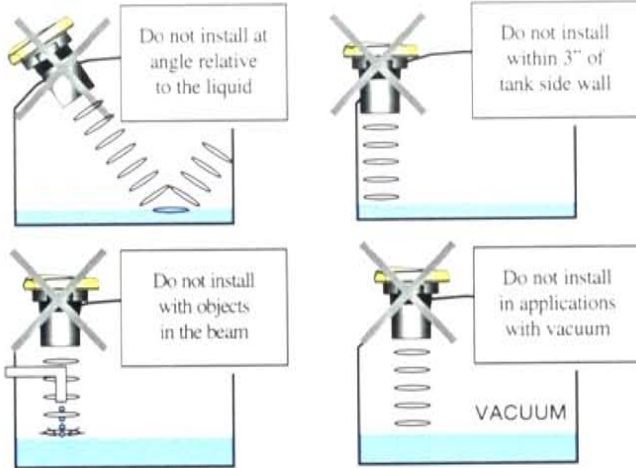

Warning

Omega Ultrasonic transmitters have been optimized for use in non-metallic fittings. For best performance, avoid the use of metallic fittings.

Install the appropriate installation fitting. Make sure that the fitting and transmitter threads are not damaged or worn. Install the transmitter with the included Viton mounting gasket. Hand tighten the transmitter within the fitting. Perform an installed leak test under normal process conditions prior to system start up.

A. Fitting Selection: Check the transmitter part number to determine the required fitting mount size and thread type. The transmitter is commonly installed in tank adapters, flanges, brackets or stand pipes. *Note: Always include the gasket when installing the LVU100 series.*

Gasket



Tank Adapter



- 1. Tank Adapter:** Select a tank adapter fitting with minimal height so as to ensure that the installed transducer will not be substantially elevated into the fitting. For the LVU104 and LVU109 versions, add a Reducer Bushing. Avoid tank adapter (thread x thread) styles and/or pipe stops forward of the installed transducer.

2" Tank Adapter Socket x Thread



Tank Adapter w/ 2"x1" Reducer Bushing



Tank Adapter Thread x Thread



INSTALLATION

Step Eleven

- 2. Riser:** Installations with tall, narrow risers can impede the acoustic signal. Select a fitting with the right riser height versus inner diameter geometry.

Riser Specifications	Inner Diameter	Maximum Height
	2" (5 cm)	3" (7.6 cm)
4" (10 cm)	8" (20 cm)	
6" (15 cm)	12" (30 cm)	

- 3. Flange:** If installing on a flange, select a flange with a thread that is above the plane of the flange. Avoid the use of blind flanges with tapped threads or flanges where the threads are even with the plane of the flange.

2" Flange w/ thread out of plane



2" Flange w/ thread in plane



If the installation requires the use of a blind flange, tap a thread 1" larger than the sensors thread and add a thread x thread Reducer Bushing.

2" Flange w/ Reducer Bushing



- 4. Side Mount Bracket:** The LVM-30 side mount bracket or equivalent can be used for open tank top installations against the side wall.

Side Mount Bracket



- 5. Stand Pipe:** A stand pipe may be used to dampen turbulence. *Omega recommends using a stand pipe when foam is present in the application.* Select a 2" pipe for the LVU104 or LVU109 Versions and a 3" pipe for all other models. The pipe length should run the measurement span. Cut a 45° notch at the bottom of the pipe and drill a 1/4" pressure equalization hole high in the dead band.

Stand Pipe

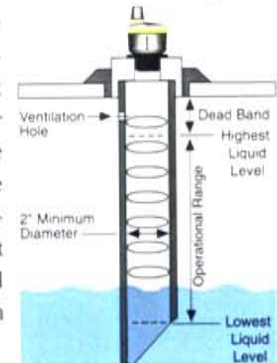

WIRING

Step Twelve

A. Wiring to a Omega LVCN-51 Controller

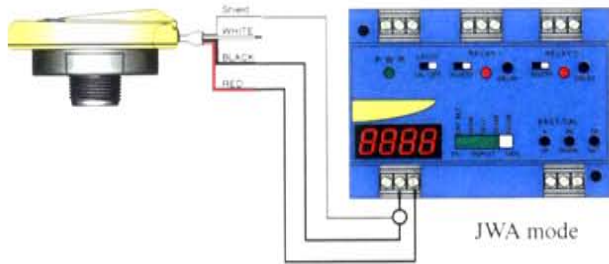

B. Wiring to a Typical Two-Wire Loop Powered Indicator

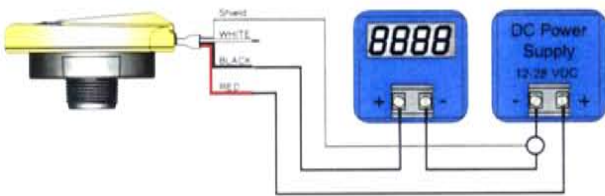

C. Wiring to a Typical Programmable Logic Controller

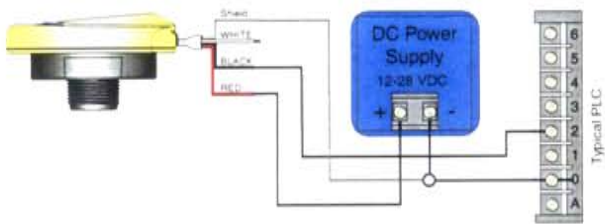

TROUBLESHOOTING

Step Thirteen

A. LED Status: During normal operation, the transmitter LED will be OFF and the 4-20 mA current will proportionately indicate level within the span. The following are the three LED diagnostic modes for troubleshooting:

- Solid LED:** Indicates that the transmitter cannot identify the level. The current will hold at 22 mA until such time that the level is acquired. Check the installation (fitting, obstructions), application (level, foam, agitation, vapor) and transmitter (coating build-up or extreme condensation on transducer).
- Continuously Flashing LED:** Indicates that the level is outside of the transmitter's calibrated span and/or range. Check the level and recalibrate the span if required.
- Three Quick LED Flashed at Power Up:** Indicates that the transmitter is installed in a challenging installation fitting that may interfere with optimum acoustic signal transmission and/or receipt. The level should be more than 2' away from the transducer for valid feedback. See installation section and check to ensure that the transmitter is installed appropriately.



B. Testing the Transmitter

- Connect a multimeter in series with the black wire to read the current output.
- Verify that the current increases (tank filling) and decreases (tank emptying) appropriately in the calibrated span.
- If not, carefully observe and attempt to correlate any installation, level or application event for more specific troubleshooting direction.

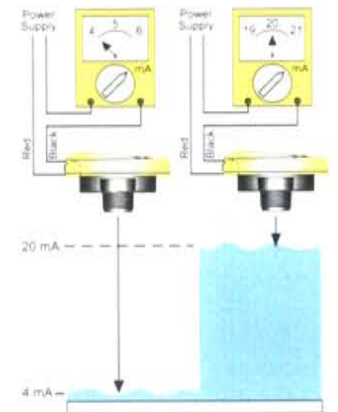

C. Factory Reset: Follow the below instructions to reset the transmitter to its original factory settings. Note that this will erase any previously input calibration set points.

- If the transmitter is wired with power ON, turn power OFF to the transmitter and wait 30 seconds before continuing.
- Connect the Black and White transmitter wires to the (-) terminal of the power supply.
- Position the transmitter such that the transducer is pointed up into the air with no reflection target.
- Add power to the transmitter for approximately 2 seconds and then power down.

Factory Set Points		
Transmitter	4 mA Setting	20 mA Setting
LVU104	4.0' (1.2m)	2" (5 cm)
LVU109	9.8' (3m)	4" (10 cm)
LVU116	16.4' (5m)	4" (10 cm)
LVU126	26.2' (8m)	8" (20 cm)