

1 YEAR
WARRANTY

MADE IN
USA

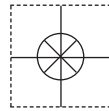

User's Guide



OS35-20

Shop online at

omega.com[®]

Ω OMEGA[®]

omega.com

e-mail: info@omega.com

For latest product manuals:

omegamanual.info



OS35-3

ISO 9001
CERTIFIED
CORPORATE QUALITY
STAMFORD, CT

ISO 9001
CERTIFIED
CORPORATE QUALITY
MANCHESTER, UK

OS35 Series Smart Infrared Temperature Sensors



OMEGAnet® Online Service
omega.com

Internet e-mail
info@omega.com

Servicing North America:

U.S.A.:
ISO 9001 Certified

Omega Engineering, Inc., One Omega Drive, P.O. Box 4047
Stamford, CT 06907-0047 USA

Toll Free: 1-800-826-6342
FAX: (203) 359-7700

TEL: (203) 359-1660
e-mail: info@omega.com

Canada:

976 Bergar
Laval (Quebec), H7L 5A1 Canada
Toll-Free: 1-800-826-6342
FAX: (514) 856-6886

TEL: (514) 856-6928
e-mail: info@omega.ca

For immediate technical or application assistance:

U.S.A. and Canada: Sales Service: 1-800-826-6342/1-800-TC-OMEGA®
Customer Service: 1-800-622-2378/1-800-622-BEST®
Engineering Service: 1-800-872-9436/1-800-USA-WHEN®

**Mexico/
Latin America:**

En Español: 001 (203) 359-7803
info@omega.com.mx

FAX: 001 (203) 359-7807
e-mail: espanol@omega.com

Servicing Europe:

Benelux:

Managed by the United Kingdom Office
Toll-Free: 0800 099 3344
FAX: +31 20 643 46 43

TEL: +31 20 347 21 21
e-mail: sales@omegaeng.nl

Czech Republic:

Frystatska 184
733 01 Karviná, Czech Republic
Toll-Free: 0800-1-66342
FAX: +420-59-6311114

TEL: +420-59-6311899
e-mail: info@omegashop.cz

France:

Managed by the United Kingdom Office
Toll-Free: 0800 466 342
FAX: +33 (0) 130 57 54 27

TEL: +33 (0) 161 37 29 00
e-mail: sales@omega.fr

Germany/Austria:

Daimlerstrasse 26
D-75392 Deckenpfronn, Germany
Toll-Free: 0800 6397678
FAX: +49 (0) 7056 9398-29

TEL: +49 (0) 7056 9398-0
e-mail: info@omega.de

United Kingdom:
ISO 9001 Certified

OMEGA Engineering Ltd.
One Omega Drive, River Bend Technology Centre, Northbank
Irlam, Manchester M44 5BD United Kingdom
Toll-Free: 0800-488-488
FAX: +44 (0) 161 777-6622

TEL: +44 (0) 161 777-6611
e-mail: sales@omega.co.uk

It is the policy of OMEGA Engineering, Inc. to comply with all worldwide safety and EMC/EMI regulations that apply. OMEGA is constantly pursuing certification of its products to the European New Approach Directives. OMEGA will add the CE mark to every appropriate device upon certification.

The information contained in this document is believed to be correct, but OMEGA accepts no liability for any errors it contains, and reserves the right to alter specifications without notice.

WARNING: These products are not designed for use in, and should not be used for, human applications.

OS35 HIGHLIGHTS

- Smart air purge assures maintenance free long term accuracy
- Smart continuous auto calibration
- All digital system
- Smart housing resists mechanical and thermal shocks
- Smart emissivity shift and ambient radiation correction
- Easy plug and play installation
- Lowest cost air purged, lineized sensor on the market
- Optics of 3:1 & 20:1 available
- Outputs of 0-5V, 0-10V, 4-20mA, & RS232
- Temperature ranges from -22 - 1832 °F (-30 - 1000 °C)
- LOW impedance, results in no offset errors due to leakage current in your input device
- Custom scaling and programming for low emissivity materials and low temperatures available



OS35-3 (3:1 FOV)

3.71" x 1.37" x 0.76" (94.3 x 34.9 x 19.4 mm)



OS35-20 (20:1 FOV)

3.71" x 1.37" x 0.76" (94.3 x 34.9 x 19.4 mm)
 & 1.63" (41.3 mm) x 0.75" diameter snout

MEASUREMENT SPECIFICATIONS

	Temperature Range	Accuracy	Repeatability	Interchangeability
OS35-3	-30-70 °C, 0-100 °C & 0-250 °C	±1 °C or 1%	± 1 BIT -30-70 °C = ± 0.1 °C 0-100 °C = ± 0.1 °C 0-250 °C = ± 0.25 °C 0-500 °C = ± 0.5 °C 0-1000 °C = ± 1 °C	±1 °C (1.8 °F) or 0.5%
		± 1.5 °C or ± 1.5%		± 1.5 °C or ± 1.5%
				±1 °C (1.8 °F) or 0.5%
OS35-20	0-100 °C, 0-250 °C, & 0-500 °C 0-1000 °C	± 1.5 °C or ± 1.5%		± 1.5 °C or ± 1.5%
		± 1.5 °C or ± 2.0%		±1 °C (1.8 °F) or 0.5%
				± 1.5 °C or ± 1.5%
			±1 °C (1.8 °F) or 0.5%	
			± 1.5 °C or ± 1.5%	

OUTLINE DRAWING

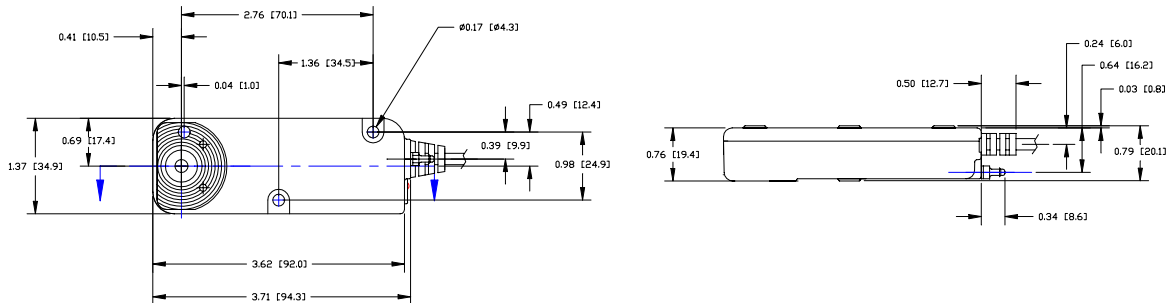



(888) TC-OMEGA (USA/Canada) / (203) 359-1660 (International)

OS35

Infrared Temperature Sensor Installation Instructions

1. Install OS35 as close as practical to view target material to be measured
2. Wire OS35 with Red to Positive Power, Black to Ground, White to Positive Output Signal, and Green to Reference Output Signal
3. Measure actual temperature of target material with OS950 Thermometer or any reliable reference
4. Adjust “offset”, “zero”, or “low cal” on input device to match reading to actual thermometer reading
5. Installation calibration complete

ERROR MESSAGES						
Condition	Priority	LED Display	0-5V	0-10V	4-20mA	RS-232
Low Power	1	OFF	Under 0.1V	Under 0.1V	Under 4mA	Not Implemented
Hardware Internal Errors	2, 13	Uniform Flash	Over 4.9V	Over 9.8V	Over 19.7mA	Not Implemented
Vsig-Offset High	3	Uniform Flash	Over 4.9V	Over 9.8V	Over 19.7mA	Not Implemented
Vsig-Offset Low	4	Uniform Flash	Over 4.9V	Over 9.8V	Over 19.7mA	Not Implemented
EMI	5	Uniform Flash	Over 4.9V	Over 9.8V	Over 19.7mA	Not Implemented
Range Error	6	Uniform Flash	Over 4.9V	Over 9.8V	Over 19.7mA	Not Implemented
High Ambient	7	Long Flash**	Over 4.9V	Over 9.8V	Over 19.7mA	Not Implemented
Low Ambient	8	Short Flash*	Over 4.9V	Over 9.8V	Over 19.7mA	Not Implemented
Too Much Heat Flow	9	Long Flash**	Over 4.9V	Over 9.8V	Over 19.7mA	Not Implemented
Too Little Heat Flow	10	Short Flash*	Over 4.9V	Over 9.8V	Over 19.7mA	Not Implemented
High Target	11	Long Flash**	Over 4.9V	Over 9.8V	Over 19.7mA	Not Implemented
Low Target	12	Short Flash*	Over 4.9V	Over 9.8V	Over 19.7mA	Not Implemented

*Six counts off one count on

**Six counts on one count off

PIN OUT					
Pin	Color	Function	Pin	Color	Function
1	White	Positive Output Signal	6	Brown	TA Pull Down Pin / IO option
2	Green	Reference Output Signal	7	Yellow	RS232_TXD / IO option
3	Red	Positive Power	8	Violet	RS232_RXD / IO option
4	Black	Ground	9	Blue	RS232_RTD (READY_TO_SEND)
5	Bare	Shield	10	Orange	RS232_CTS (CLEAR_TO_SEND)

AVAILABLE MODELS

OS35-3-MA-100C-24V	Infrared temperature sensor, 3:1 optics, 0 to 100 °C range
OS35-3-MA-250C-24V	Infrared temperature sensor, 3:1 optics, 0 to 250 °C range
OS35-3-MA-70C-24V	Infrared temperature sensor, 3:1 optics, -30 to 70 °C range
OS35-20-MA-100C-24V	Infrared temperature sensor, 20:1 optics, 0 to 100 °C range
OS35-20-MA-250C-24V	Infrared temperature sensor, 20:1 optics, 0 to 250 °C range
OS35-20-MA-500C-24V	Infrared temperature sensor, 20:1 optics, 0 to 500 °C range
OS35-20-MA-1000C-24V	Infrared temperature sensor, 20:1 optics, 0 to 1000 °C range

Note: * Note: For 12 V power requirement, change 24 V in Model number to 12 V, no price change. For 5 V output, change MA to 5 V, no price change. For 10 V output, which is available only on 24 V power models, change MA to 10 V, no price change. For RS232 output, which is available only on 250°C range with 12 V power, change MA to RS, no price change. Comes with air tubing.

Ordering Example: (1) **OS35-3-MA-100C-24V**

ELECTRICAL SPECIFICATIONS

	OS35-3		OS35-20
LINEAR TEMPERATURE RANGES <small>(custom scaling also available upon request)</small>	-30-70 °C (-22-158 °F) 0-100 °C (32-212 °F) 0-250 °C (32- 482 °F)		0-100 °C (32-212 °F), 0-250 °C (32- 482 °F), 0-500 °C (32- 932 °F), 0-1000 °C (32 - 1832 °F)
OUTPUT	0-5V, 0-10V (24VDC power only), 4-20mA (50 ohm max), RS232 (12VDC power only)		
UPDATE TIME	Approximately 250 msec.		
FIRST READING UPON POWER UP	Approximately 2 seconds		
EMISSIVITY SETTING	0.90 (custom low emissivity settings available for metals, etc. upon request)		
SPECTRAL RESPONSE	5.5 to 20 microns (other ranges available for specific applications, thin films, etc.)		
POWER	12 or 24 VDC (10%). Shuts off when voltage is functionally low.		
OUTPUT IMPEDANCE	750 ohms on 0-5V and 0-10V models		
MINIMUM LOAD IMPEDANCE	100 K ohms		
MAXIMUM LOOP IMPEDANCE	1 K ohm max		
POWER CONSUMPTION	< 800 mW at 24 VDC and < 600 mW at 12VDC		

MECHANICAL SPECIFICATIONS

	OS35-3		OS35-20
Minimum Spot Size	0.12" (3.0 mm)		0.625" (15.9 mm)
Ambient Temperature Range	0 to 70 °C (32 to 158 °F)		
Storage Temperature	-10 to 70 °C (14 to 158 °F)		
Construction	Heavy Duty Alloy Casting		
Weight	Approximately 8 oz. (227 g)		
Relative Humidity	95% non condensing		
Air Purge	Integral built in air purge with small sized aperture and heat exchanged which minimizes drift for superb accuracy		
Cable	3 ft (0.9 m) of 5 conductor, tinned copper, twisted pair, polypropylene, insulated with shielded wire		
Ratings	NEMA , IP54 (with air on)		

ORDERING INFORMATION

OS35-F-P-O-T

F	FIELD OF VIEW	P	POWER	O	OUTPUT	T	TEMPERATURE RANGE
.3	3:1	12V	12 VDC	05	0-5V	70C	-30-70C
		24V	24 VDC	010	0-10V	100C	0-100C
.20	20:1			420	4-20 mA	250C	0-250C
				232	RS232	500C	0-500C
						1000C	0-1000C

OPTION: Add Ta to any part # to add ambient temperature option to output ambient temperature

NOTE: 0-10V only available in 24VDC and RS232 only available in 12VDC

Example: OS35-3-24V-420-250C (with 4-20mA output measuring target temperature from 0-250C) or OS35-3-24V-420-250C-Ta (with 4-20mA outputting target temperature and ambient temperature from 0-250C)

OS35™ and OS35-RS™



800-826-6342 (USA/Canada)
(203) 359-1660 (International)
www.omega.com

Infrared Temperature Sensor

INSTALLATION INSTRUCTIONS

The following procedure is recommended:

1. Install the SmartIRt/c as close as practical to view the target material to be measured.
2. Wire the SmartIRt/c to the controller, PLC, etc. in standard fashion (see PIN-OUT and wiring diagram)
3. Bring the process up to normal operating temperature and measure the actual temperature of the target material with the Microscanner D-Series, DX-Series Infrared Thermometer or any other reliable reference.
4. Adjust "input offset," "zero," "low cal," on the readout device to match the reading of your reference.

Installation Complete. (For OEM installations preset the same adjustments. Individual calibration is not required.)

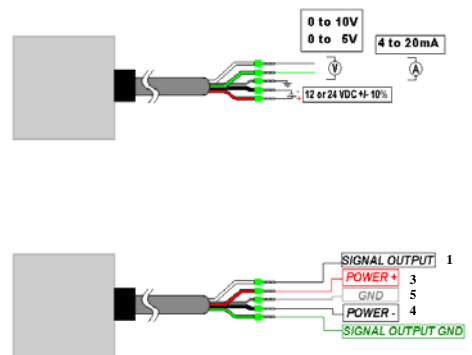

WIRING DIAGRAM

PIN OUT

Carol C074 Series/Belden 953 Series/Alpha 630 Series

Pin	Color	Function	Pin	Color	Function
1	White	Positive Output Signal	6	Brown	TA Pull Down Pin / IO option
2	Green	Reference Output Signal	7	Yellow	RS232_TXD / IO option
3	Red	Positive Power	8	Violet	RS232_RXD / IO option
4	Black	Ground	9	Blue	RS232_RTD (READY_TO_SEND)
5	Bare	Shield	10	Orange	RS232_CTS (CLEAR_TO_SEND)

ORDERING INFORMATION

SmartIRt/c-F-P-O-T or Smart-microIRt/c-F-P-O-T (F is -.SV, .4, .4SV only for Smart-microIRt/c)

F	FIELD OF VIEW	P	POWER	O	OUTPUT	T	TEMPERATURE RANGE
.3	3:1	12V	12 VDC	05	0-5V	100C	0-100C
.5	5:1	24V	24 VDC	010	0-10V	250C	0-250C
.20	20:1			420	4-20 mA	500C	0-500C
.40	40:1			232	RS232	1000C	0-1000C
-	1:2					70C	-30-70C
.SV	1:2						
.4	4:1						
.4SV	4:1						

OPTION: Add Ta to any part # to add ambient temperature option to output ambient temperature surrounding sensor

NOTE: 0-10V only available in 24VDC and RS232 only available in 12VDC from 0-250C

Examples: SmartIRt/c.3-24V-420-250C (3:1 field of view, 24VDC power, 4-20mA output from 0-250C),
Smart-microIRt/c-12V-05-250C (1:2 field of view, 12VDC power, 0-5V output from 0-250C). or
SmartIRt/c.3-24V-420-250C-Ta (with 4-20mA outputting target temperature and ambient temperature from 0-250C)

	0-5V	0-10V	4-20mA	RS232
Sensing Range	-30 to 70 °C, 0 to 100 °C, 0 to 250 °C, 0 to 500 °C, or 0 to 1000 °C			
Ambient Temperature Range	0 °C to 70 °C (internal case temperature)			
Storage Temperature Range	-10 °C to 70 °C			
Field of View of Sensing Element	1:2, 3:1, 4:1, 5:1, 20:1, or 40:1 (distance:spot)			
Minimum Spot size	3 mm (0.1") (Smart-micro) 5 mm (0.2") (Smart) (16 mm (0.625")) (SmartIRt/c.20 and 40)			
Dominant Spectral Response	5 to 14 um (Smart-micro), 5.5 to 20 um (Smart)			
Impedance	Less than 1 Kohms	50 ohm max	NA	
Emissivity Setting (e)	0.90 can be factory adjusted			
Measurement Type	Thermopile			
Resolution	10 bit***		4 Digit w/ floating decimal	
Update Time	Less than 250ms after first reading**			
Response Time (95% of step change)	Less than 650 ms**			
Bandwidth	Typically 5Hz			
First Reading in	Less than 2 seconds			
Accuracy (Includes Repeatability and Interchangeability)	Typically: ± 1 °C (± 1.8 °F) or 1% of reading at e 0.9			
Recommended Power Supply	12 \pm 10% V DC or 24 \pm 10% V DC; depending on model			
Power Accepted*	Shuts off when voltage is functionally low*			
Power Consumption	12V power less then 400mW 24V Power less than 800 mW			
Dimensions	Contact Exergen for Drawing			
Housing	Zinc-Aluminum Alloy Z-12 (ISO/DIS 301)			
Sensor Connection	3 foot pigtail (and 3 feet from sensor to box on Smart-microIRt/c)		DB9 and loose power wires	
Recommended Air Purge Pressure	3 PSI			
Maximum Air Pressure	20 PSI - may cause reading errors			
Air Cleanliness	Instrument Air is Recommended, ANSI/ISA-7.0.01-1996			
Humidity	Non-Condensing - ISA-71.01-1985 Environment Class C Severity X			
Shock	100G			
Weight	Approximately 200 grams (7oz.)			
LED	Constantly on for normal operation			

* The unit will not give an error message if the input voltage exceeds recommended high limit, but functionality or accuracy is not guaranteed when exceeding the Recommended Power Supply voltage.

** At room temperature

*** Current Output 10bit 0-20mA



WARRANTY/DISCLAIMER

OMEGA ENGINEERING, INC. warrants this unit to be free of defects in materials and workmanship for a period of **13 months** from date of purchase. OMEGA's WARRANTY adds an additional one (1) month grace period to the normal **one (1) year product warranty** to cover handling and shipping time. This ensures that OMEGA's customers receive maximum coverage on each product.

If the unit malfunctions, it must be returned to the factory for evaluation. OMEGA's Customer Service Department will issue an Authorized Return (AR) number immediately upon phone or written request. Upon examination by OMEGA, if the unit is found to be defective, it will be repaired or replaced at no charge. OMEGA's WARRANTY does not apply to defects resulting from any action of the purchaser, including but not limited to mishandling, improper interfacing, operation outside of design limits, improper repair, or unauthorized modification. This WARRANTY is VOID if the unit shows evidence of having been tampered with or shows evidence of having been damaged as a result of excessive corrosion; or current, heat, moisture or vibration; improper specification; misapplication; misuse or other operating conditions outside of OMEGA's control. Components in which wear is not warranted, include but are not limited to contact points, fuses, and triacs.

OMEGA is pleased to offer suggestions on the use of its various products. However, OMEGA neither assumes responsibility for any omissions or errors nor assumes liability for any damages that result from the use of its products in accordance with information provided by OMEGA, either verbal or written. OMEGA warrants only that the parts manufactured by the company will be as specified and free of defects. OMEGA MAKES NO OTHER WARRANTIES OR REPRESENTATIONS OF ANY KIND WHATSOEVER, EXPRESSED OR IMPLIED, EXCEPT THAT OF TITLE, AND ALL IMPLIED WARRANTIES INCLUDING ANY WARRANTY OF MERCHANTABILITY AND FITNESS FOR A PARTICULAR PURPOSE ARE HEREBY DISCLAIMED. LIMITATION OF LIABILITY: The remedies of purchaser set forth herein are exclusive, and the total liability of OMEGA with respect to this order, whether based on contract, warranty, negligence, indemnification, strict liability or otherwise, shall not exceed the purchase price of the component upon which liability is based. In no event shall OMEGA be liable for consequential, incidental or special damages.

CONDITIONS: Equipment sold by OMEGA is not intended to be used, nor shall it be used: (1) as a "Basic Component" under 10 CFR 21 (NRC), used in or with any nuclear installation or activity; or (2) in medical applications or used on humans. Should any Product(s) be used in or with any nuclear installation or activity, medical application, used on humans, or misused in any way, OMEGA assumes no responsibility as set forth in our basic WARRANTY/DISCLAIMER language, and, additionally, purchaser will indemnify OMEGA and hold OMEGA harmless from any liability or damage whatsoever arising out of the use of the Product(s) in such a manner.

RETURN REQUESTS/INQUIRIES

Direct all warranty and repair requests/inquiries to the OMEGA Customer Service Department. BEFORE RETURNING ANY PRODUCT(S) TO OMEGA, PURCHASER MUST OBTAIN AN AUTHORIZED RETURN (AR) NUMBER FROM OMEGA'S CUSTOMER SERVICE DEPARTMENT (IN ORDER TO AVOID PROCESSING DELAYS). The assigned AR number should then be marked on the outside of the return package and on any correspondence.

The purchaser is responsible for shipping charges, freight, insurance and proper packaging to prevent breakage in transit.

FOR **WARRANTY** RETURNS, please have the following information available BEFORE contacting OMEGA:

1. Purchase Order number under which the product was PURCHASED,
2. Model and serial number of the product under warranty, and
3. Repair instructions and/or specific problems relative to the product.

FOR **NON-WARRANTY** REPAIRS, consult OMEGA for current repair charges. Have the following information available BEFORE contacting OMEGA:

1. Purchase Order number to cover the COST of the repair,
2. Model and serial number of the product, and
3. Repair instructions and/or specific problems relative to the product.

OMEGA's policy is to make running changes, not model changes, whenever an improvement is possible. This affords our customers the latest in technology and engineering.

OMEGA is a registered trademark of OMEGA ENGINEERING, INC.

© Copyright 2010 OMEGA ENGINEERING, INC. All rights reserved. This document may not be copied, photocopied, reproduced, translated, or reduced to any electronic medium or machine-readable form, in whole or in part, without the prior written consent of OMEGA ENGINEERING, INC.

Where Do I Find Everything I Need for Process Measurement and Control? **OMEGA...Of Course!** *Shop online at omega.comSM*

TEMPERATURE

- Thermocouple, RTD & Thermistor Probes, Connectors, Panels & Assemblies
- Wire: Thermocouple, RTD & Thermistor
- Calibrators & Ice Point References
- Recorders, Controllers & Process Monitors
- Infrared Pyrometers

PRESSURE, STRAIN AND FORCE

- Transducers & Strain Gages
- Load Cells & Pressure Gages
- Displacement Transducers
- Instrumentation & Accessories

FLOW/LEVEL

- Rotameters, Gas Mass Flowmeters & Flow Computers
- Air Velocity Indicators
- Turbine/Paddlewheel Systems
- Totalizers & Batch Controllers

pH/CONDUCTIVITY

- pH Electrodes, Testers & Accessories
- Benchtop/Laboratory Meters
- Controllers, Calibrators, Simulators & Pumps
- Industrial pH & Conductivity Equipment

DATA ACQUISITION

- Data Acquisition & Engineering Software
- Communications-Based Acquisition Systems
- Plug-in Cards for Apple, IBM & Compatibles
- Data Logging Systems
- Recorders, Printers & Plotters

HEATERS

- Heating Cable
- Cartridge & Strip Heaters
- Immersion & Band Heaters
- Flexible Heaters
- Laboratory Heaters

ENVIRONMENTAL MONITORING AND CONTROL

- Metering & Control Instrumentation
- Refractometers
- Pumps & Tubing
- Air, Soil & Water Monitors
- Industrial Water & Wastewater Treatment
- pH, Conductivity & Dissolved Oxygen Instruments