

1 YEAR
WARRANTY

CE

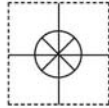

User's Guide



Shop online at

omega.com[®]
ΩOMEGA[®]

omega.com
e-mail: info@omega.com

PTC-15 Programmable Timing Controller

PTC-15 Programmable Timing Controller

FRONT PANEL FUNCTIONS

- SEL
 Selects view set time mode. Allows access to set point for adjustment in set mode. Moves adjustment to the next digit in set and program mode. Allows access to parameters for adjustment in program mode.
- PRG
 Selects set mode. Selects program mode when held for >4 seconds. Steps through individual timer functions when in program mode. Exits program mode when held for >4 seconds at Mde prompt in program mode.
- ▲
 Increments the timer being displayed in view mode. Increments the timer being adjusted in set mode. Increases a single digit in set mode. Steps up through the function menu in program mode. Increases a parameter value or option in program mode.
- ▼
 Decrements the timer being displayed in view mode. Decrements the timer being adjusted in time set mode. Decreases a single digit in set mode. Steps up through function menu in program mode. Decreases a parameter value or option in program mode.

WIRING DIAGRAM

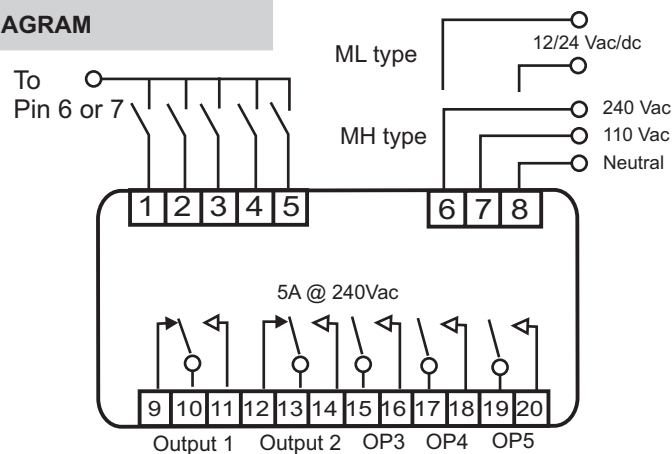

VIEW MODE

The view mode is used to determine which timer is displayed, or to view (but not change) the set times. To change the timer being viewed during normal running :-

1. Press \wedge or \vee to show the currently selected timer (T1 at default).
2. Press \wedge or \vee again to change the selected timer. The timer number (e.g. T3 = Timer 3) will be displayed for 3 seconds and that timer will then be in view. If the timer selected is set to relay mode, the display will show "rly".

To view set times:-

3. Press SEL. The display will show the timer and set point number (e.g. St21 = timer 2, set time 1) for 3 seconds and then shows that set time for a further 3 seconds. If there is a second set time (i.e. in cct and dodo modes) this can be displayed by pressing SEL again.
4. Use \wedge and \vee while viewing the set time to select the timer set point to be displayed.
5. The timer will return to normal running after displaying the set time. The last timer to be displayed will now be in view. To view a different timer while running, repeat steps 1 and 2 above.

TIMING MODES

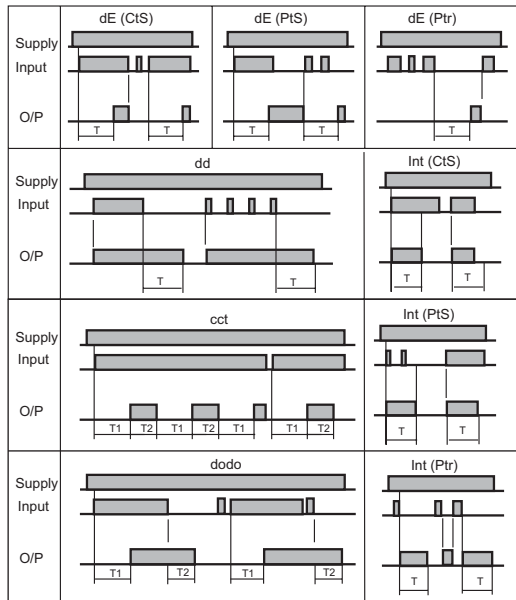

PROGRAM PARAMETER MAP

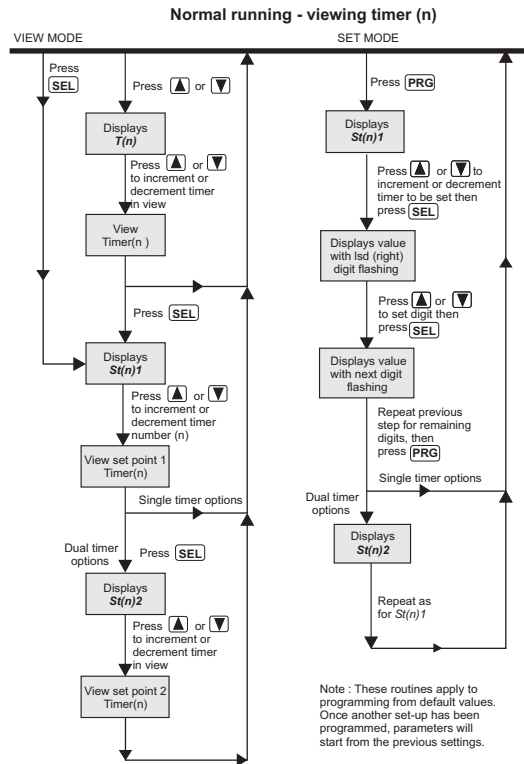

PROGRAM PARAMETERS

Parameter	Function	Default	Range/Option
St11-St51	First timing value	9000	0 to Timing range
St12-St52	Second timing value	9000	0 to Timing range
PASS	Password to access Program	0000	0 = No Password 1 - 4999 for adjustable times 5000-9999 for locked times 1996 Override Password
MODE (ndE1-5)	Timing Mode Selection	dE	dE = Delay On int = Interval Time dd = Delay Off cct = Cycling Timer dodo = Delay On Delay Off rLy = Relay Mode
r nG1 r nG2	Timing Range Selection	SECS	SECS = 0.1 to 999.9 secs M-S = 1sec to 99min59sec H-M = 1min to 99hrs59min
St	Start Mode	CtS	CtS = Close to Start PtS = Pulse to Start Ptr = Pulse to Reset
ncYc	Cycle Counter	0000	0000 = Continuous 1-9999 cycles
tdir	Counting Direction	uP	uP or dn = Up or Down

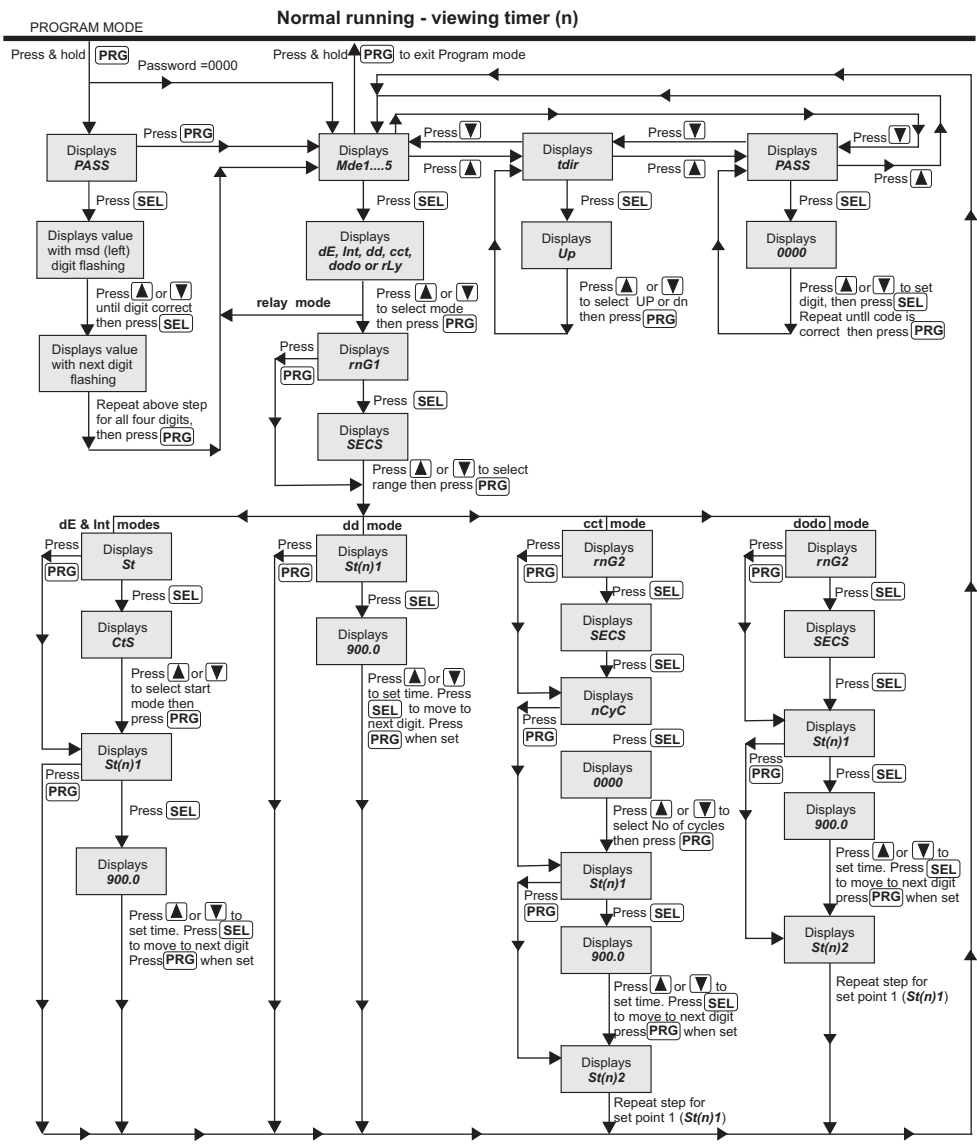

SET MODE

Set mode is used to change the set times.

1. Press PRG. The display will show the timer and set point number (e.g. ST21 = timer 2, set time 1).
2. Use \wedge and \vee to select the timer to be set.
3. When the relevant timer is selected, press SEL to allow the set time to be changed.
4. Adjust the set time one digit at a time using \wedge and \vee . Press SEL to move between digits.
5. When adjustment is complete, press PRG to store the new setting and move on to the second set time if selected. If a single time mode is in use, the timer will return to run mode.
6. Repeat steps 4 and 5 to set the second time.
7. Press PRG to return to run mode. The last timer to be set will now be in view. To view a different timer while running, repeat steps 1 & 2 in view mode above.

ADJUSTING SET TIME

Program mode is used to set up the operating functions and parameters of the timer. (Refer to the parameter map for programming details)

1. Press and hold PRG. The display will show PASS (if a password > 0 has been set). Press SEL and use \wedge and \vee to enter each digit of the password. Use SEL to move between password digits. When complete press PRG to access the program functions. NOTE : if no password is set (PASS=0000) the display will go directly to the first program parameter (Mde1).
2. Use \wedge and \vee to move around the program menu (Mde1, Mde2, Mde3, Mde4, Mde5, tdir, PASS - Mde1, Mde2 ... etc.)
3. Press SEL to access the program parameter to be changed, use \wedge and \vee to change the parameter (using SEL to move between digits where required).
4. Press PRG to store the change and move on to the next variable within a particular timer set up (eg. Mde1, rng1, St, St11 - Mde1, rng1...etc)
5. Use \wedge and \vee at the Mde prompt to move around the program menu.
6. Press and hold PRG at any Mde prompt to exit program mode. The timer active when exiting from program mode will now be in view. To view a different timer while running, repeat steps 1 & 2 in view mode above.

NOTES

1. Set and program modes will time out if no buttons are pressed for 1 minute. The timer will return to run mode.
2. When the program routine has been accessed all timing stops, is reset and all outputs are de-energised.
3. Timing continues in set mode. The new set times take effect when the timer is next started.
4. The output indicator will light when the relevant output is energised.

DIMENSIONS

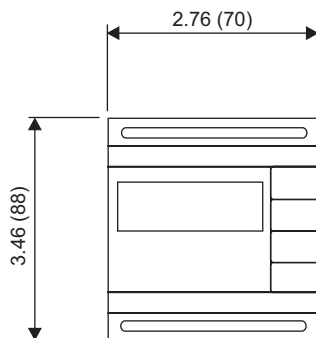

Panel cut-out 2.755 x 1.77 (70 x 45)

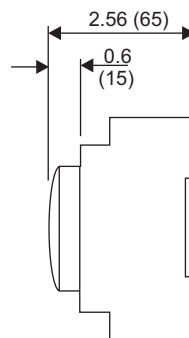

All dimensions in inches (mm)