



# User's Guide

**Shop online at**

**omega.com<sup>®</sup>**  
— OMEGA<sup>®</sup> —

**omega.com**

**e-mail: info@omega.com**

**For latest product manuals:**

**omegamanual.info**



**MADE IN  
USA**

## IP211, EP211 SERIES





**OMEGAnet® Online Service**  
**www.omega.com**

**Internet e-mail**  
**info@omega.com**

### **Servicing North America:**

**USA:** One Omega Drive, P.O. Box 4047  
 Stamford CT 06907-0047  
ISO 9001 Certified TEL: (203) 359-1660 FAX: (203) 359-7700  
 e-mail: info@omega.com

**Canada:** 976 Bergar  
 Laval (Quebec) H7L 5A1, Canada  
 TEL: (514) 856-6928 FAX: (514) 856-6886  
 e-mail: info@omega.ca

### **For immediate technical or application assistance:**

**USA and Canada:** Sales Service: 1-800-826-6342 / 1-800-TC-OMEGA®  
 Customer Service: 1-800-622-2378 / 1-800-622-BEST®  
 Engineering Service: 1-800-872-9436 / 1-800-USA-WHEN®  
 TELEX: 996404 EASYLINK: 62968934 CABLE: OMEGA

**Mexico:** En Español: (001) 203-359-7803 e-mail: espanol@omega.com  
 FAX: (001) 203-359-7807 info@omega.com.mx

### **Servicing Europe:**

**Benelux:** Postbus 8034, 1180 LA Amstelveen, The Netherlands  
 TEL: +31 (0)20 3472121 FAX: +31 (0)20 6434643  
 Toll Free in Benelux: 0800 0993344  
 e-mail: sales@omegaeng.nl

**Czech Republic:** Frystatska 184, 733 01 Karviná, Czech Republic  
 TEL: +420 (0)59 6311899 FAX: +420 (0)59 6311114  
 Toll Free: 0800-1-66342 e-mail: info@omegashop.cz

**France:** 11, rue Jacques Cartier, 78280 Guyancourt, France  
 TEL: +33 (0)1 61 37 2900 FAX: +33 (0)1 30 57 5427  
 Toll Free in France: 0800 466 342  
 e-mail: sales@omega.fr

**Germany/Austria:** Daimlerstrasse 26, D-75392 Deckenpfronn, Germany  
 TEL: +49 (0)7056 9398-0 FAX: +49 (0)7056 9398-29  
 Toll Free in Germany: 0800 639 7678  
 e-mail: info@omega.de

**United Kingdom:** One Omega Drive, River Bend Technology Centre  
ISO 9002 Certified Northbank, Irlam, Manchester  
 M44 5BD United Kingdom  
 TEL: +44 (0)161 777 6611 FAX: +44 (0)161 777 6622  
 Toll Free in United Kingdom: 0800-488-488  
 e-mail: sales@omega.co.uk

It is the policy of OMEGA to comply with all worldwide safety and EMC/EMI regulations that apply. OMEGA is constantly pursuing certification of its products to the European New Approach Directives. OMEGA will add the CE mark to every appropriate device upon certification.

The information contained in this document is believed to be correct, but OMEGA Engineering, Inc. accepts no liability for any errors it contains, and reserves the right to alter specifications without notice.

**WARNING:** These products are not designed for use in, and should not be used for, human applications.

## PRINCIPLE OF OPERATION

The transducer is a force balance device in which a coil is suspended in the field of a magnet by a flexure. Current flowing through the coil generates axial movement of the coil and flexure. The flexure moves against the end of a nozzle, and creates a back pressure in the nozzle by restricting air flow. This back pressure acts as a pilot pressure to an integral booster relay. Consequently, as the input signal increases (or decreases, for reverse acting), output pressure increases proportionally.

Zero and span are calibrated by turning easily accessible adjusting screws on the front face of the unit. The zero adjustment causes the nozzle to move relative to the flexure. The span adjustment is a potentiometer that limits the flow of current through the coil. A thermistor circuit in series with the coil provides temperature compensation.

## MOUNTING

The transducer can be mounted at any angle, but should be calibrated after mounting. For maximum output pressure stability, it should be mounted vertically in a vibration free location or such that the vibration is isolated to the X and Z axis as shown in **Figure 3**.

**Pipe:** Due to its light weight, the transducer may be supported by the piping used for the supply and output.

**Panel:** (with access to rear of panel) Attach transducer (**See Fig. 3**), to panel using two 10-32 screws and two threaded mounting holes on the back of the unit.

**Panel:** (with no access to rear of panel) Attach bracket (**see Fig 1 and 3**), to transducer using two 10-32 screws on the back of the unit and mount bracket to panel using four 8-32 screws.

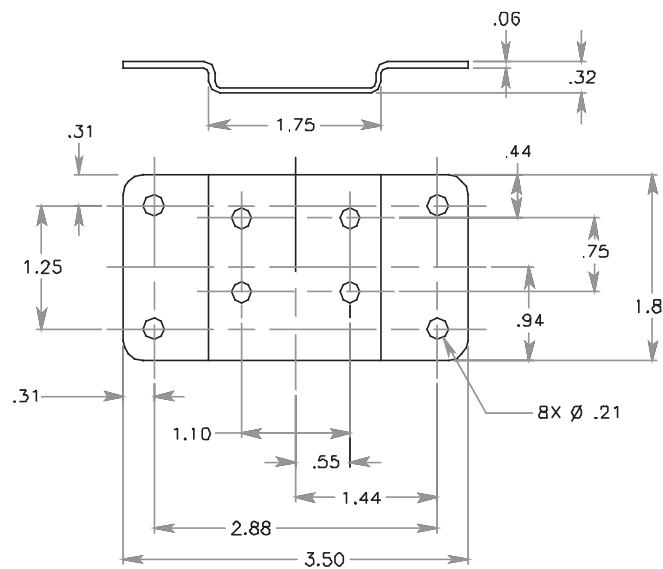

**Figure 1**

## AIR CONNECTIONS

- Supply Air must be instrument quality air regulated between the minimum and maximum specified on the nameplate of the transducer.
- Instrument quality air consists of :
  - a A dew point less than 35°F
  - b No particles larger than three microns
  - c Maximum oil content of 1 ppm
- All unused ports must be plugged.

**Supply:** Connect supply to the 1/4" NPT ports marked "IN" on the base of the transducer. Avoid getting pipe sealant inside the piping or transducer.

**Output:** Connect output to the 1/4" NPT ports marked "OUT" on the base of the transducer. The pipe plugs may be removed from the two auxiliary output ports for a pressure gauge or as an alternative output port.

## PRODUCT CERTIFICATIONS

### FACTORY MUTUAL

**INTRINSIC SAFETY:** The (I/P Models I/P211-X15-ISF and I/P211-X27-ISF) transducers are rated intrinsically safe by FM for:  
 - CLASS I, DIVISION 1, GROUPS A,B,C,D T6, Ta=40°C HAZARDOUS LOCATIONS when installed in accordance with interconnection drawing 990-440-000, and the specific barrier models.

**NOTICE:** The above ratings only apply when installed per Interconnection Diagram 990-440-000  
 - Nonincendive for CLASS I, DIVISION II, GROUPS A, B, C, D.

### CANADIAN STANDARDS ASSOCIATION

**INTRINSIC SAFETY:** The I/P (I/P211-X15-ISC and I/P211-X15-ISC) are rated intrinsically safe by CSA for: Class I Groups A, B, C, and D; Class II Groups E, F, and G; and Class III, when connected through certified diode safety barriers in accordance with Interconnection diagram, 990-440-000

## ELECTRICAL CONNECTIONS

### PRECAUTIONS TO BE OBSERVED DURING INSTALLATION



The Transducers were tested at the EMC Test Centre, Dunfermline, Fife, KY11 5LB to the Electromagnetic Compatibility Directive effective January 1, 1996. The relevant EMC specifications tested were the following: EN 50081-1 (1992) and EN 50082-1 (1992). A Technical Construction File, Serial #107 was written and Certificate of Conformity issued by a Competent Body.

EN 50081-1 (1992): Test results confirmed that no precautions need to be observed during installation regarding electromagnetic emissions from the I/P & E/P 211 Transducers.

EN 50082-1 (1992): The following precautions should be taken during installation to maintain the advertised accuracy specifications for the Transducers. The input wiring to the transducer should be isolated from other high voltage transient wiring. The momentary switching on and off of nearby relays, motors, or other high capacitive or inductive loads can have a minor effect on the terminal based linearity specification (1.0% of span, standard range models). Any change in output pressure is minimal and momentarily, and is considered to be within its performance capabilities. Use of a ferrite bead collar on the input wires entering the transducer is recommended should installation next to high electromagnetic interference be necessary.

Connect electrical signal to the wires exiting from the side of transducer through the 1/2" NPT conduit fitting.

For **DIRECT ACTING:** (where increasing the input signal increases output pressure), connect the positive input signal to the **black** transducer lead, and the negative to the **white** transducer lead.

For **REVERSE ACTING:** (where increasing the input signal decreases output pressure), connect the positive input signal to the **white** transducer lead, and the negative to the **black** transducer lead. Agency Approved Models may also be operated in either mode.

## CALIBRATION

Once the transducer has been mounted, and air supply connections finished, the unit's calibration must be checked before placing into service.

**Note:** input percentage refers to the following examples:

If 4 to 20 mA	If 0 to 10 VDC	If 0 to 5 VDC	If 1 to 5 VDC
0% = 4 mA	0% = 0.00 VDC	0% = 0.00 VDC	0% = 1.00 VDC
25% = 8 mA	25% = 2.50 VDC	25% = 1.25 VDC	25% = 2.00 VDC
50% = 12 mA	50% = 5.00 VDC	50% = 2.50 VDC	50% = 3.00 VDC
75% = 16 mA	75% = 7.50 VDC	75% = 3.75 VDC	75% = 4.00 VDC
100% = 20 mA	100% = 10.00 VDC	100% = 5.00 VDC	100% = 5.00 VDC

### Forward Acting

1. Apply the 0% input signal to unit and adjust the "Zero" adjusting screw to the low setpoint output. Turn screw counter-clockwise to increase output. If there is no change in output, keep turning adjustment screw counter-clockwise until output begins to rise. It is imperative that the output pressure be closely monitored as turning the zero screw excessively could damage the flexure.
2. Apply the 100% signal to unit and adjust "Span" adjusting screw until output is at the high setpoint.
3. **IMPORTANT:** On I/P (Current) input models, turn the "Span" adjusting screw counter-clockwise to increase output. On E/P (Voltage) input models, turn the "Span" adjusting screw clockwise to increase the output pressure.
4. Repeat steps 1 & 2 until unit is calibrated.

### Reverse Acting

1. Apply the 0% input signal to unit and adjust "Zero" adjusting screw until output reaches the high output pressure setpoint. Turn counter-clockwise to increase.
2. Apply the 100% input signal to unit and adjust "Span" adjustment until output pressure is at the low setpoint. **IMPORTANT:** On I/P (Current) input models, turn the "Span" adjusting screw clockwise to increase output. On E/P (Voltage) input models, turn the "Span" adjusting screw counter-clockwise to increase the output pressure.
3. Repeat steps 1 & 2 until unit is calibrated.

**A** M-4110/1104 IP211, EP211 SERIES

FIGURE 2

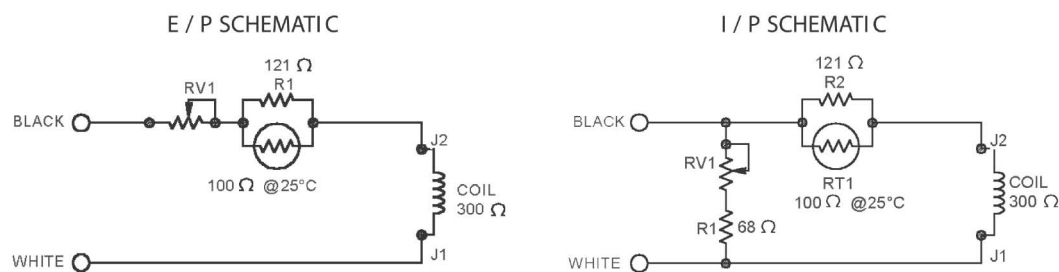

**SIGNAL IMPEDANCE**

The input impedance will vary depending upon the potentiometer setting of the “SPAN (RV1)”, (**SEE FIG. 2**). The I/P circuit design consists of a resistor and potentiometer in parallel with the coil/flexure. The E/P circuit utilizes a potentiometer in series with the coil/flexure. The following are some of the nominal impedances that would be measured across the signal leads of the average calibrated transducer. These values are helpful when determining power requirements and for trouble shooting.

INPUT SIGNAL	OUTPUT RANGE	NOMINAL IMPEDANCE (OHMS)	POTENTIOMETER RV1 SIZE (OHMS)
4-20mA	3-15 PSIG	180	1000
4-20mA	3-27 PSIG	215	1000
4-20mA	3-120 PSIG	260	1000
4-20mA	2-60 PSIG	225	1000
0-5 VDC	3-15 PSIG	615	500
0-5 VDC	3-27 PSIG	530	500
0-10 VDC	3-120 PSIG	800	1000
0-5 VDC	2-60 PSIG	500	1000
4-20mA	6-30 PSIG	215	1000

**TROUBLESHOOTING**

SYMPTOM	CAUSE	SOLUTION
<b>Sluggish Performance or Reduced Range.</b>	1) Plugged or blocked orifice.	1) Remove orifice screw and clean orifice with wire or pin <0.009" diameter
	2) Supply pressure too low.	2) Supply pressure must be at least 5 PSIG above the 100% output.
<b>Transducer remains at start up no matter the input signal.</b>	1) Zero set too low.	1) Turn zero adjustment counter-clockwise until output pressure increases then follow calibration procedure.
	2) Electrical connection has opened or wrong type of signal applied.	2) Check electrical connections to insure that there is a correct input signal reaching the transducer.
<b>Transducer works in reverse. (Pressure goes down when input signal goes up.)</b>	Wires connected in reverse	Insure wiring is connected per Electrical Connection section.
<b>Output Pressure same as supply Pressure with no signal effect.</b>	Pneumatic connections reversed or supply and output both connected to "IN" ports.	Insure supply is connected to port marked "IN" and output is connected to port marked "OUT".

**Note:** If you experience an unusual problem that is not described in this section, or if troubleshooting procedures will not restore the unit to normal operation, please contact Omega.

**A** M-4110/1104 IP211, EP211 SERIES

**Figure 3**

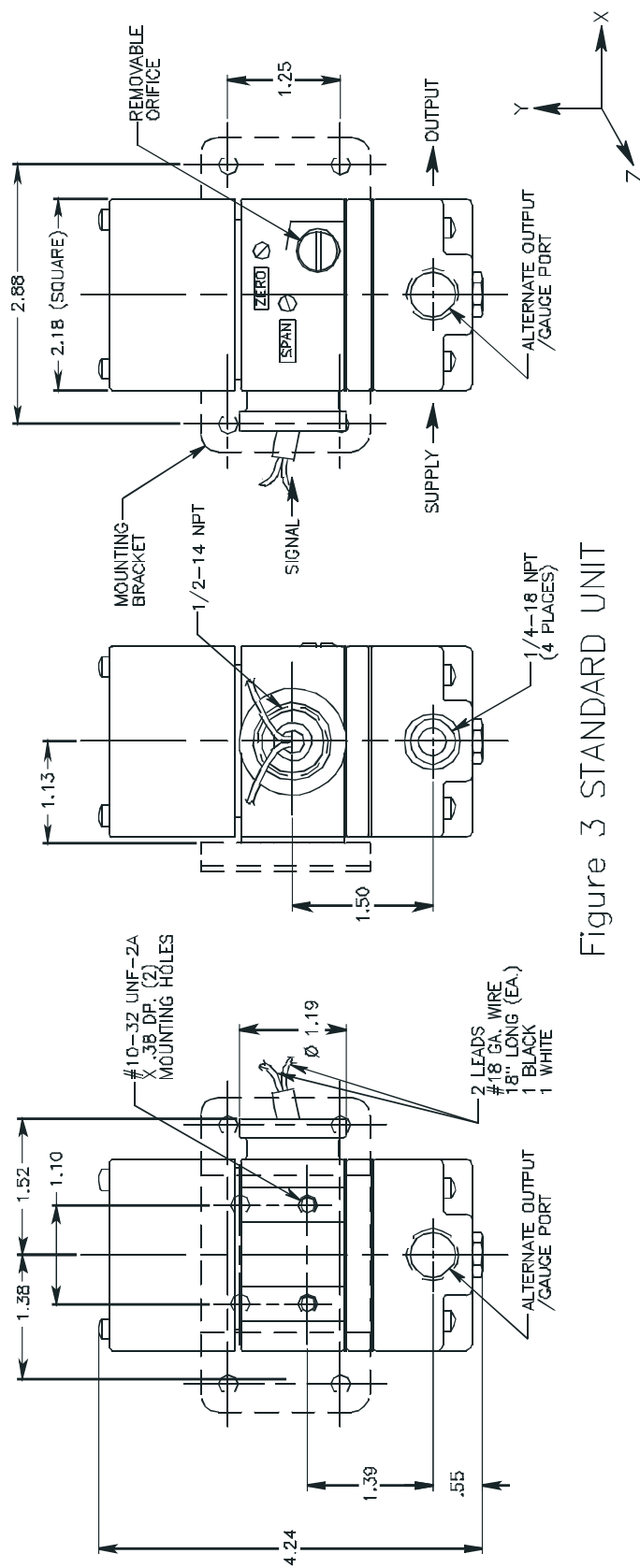

Figure 3 STANDARD UNIT



## WARRANTY/DISCLAIMER

OMEGA ENGINEERING, INC. warrants this unit to be free of defects in materials and workmanship for a period of **13 months** from date of purchase. OMEGA's WARRANTY adds an additional one (1) month grace period to the normal one **(1) year product warranty** to cover handling and shipping time. This ensures that OMEGA's customers receive maximum coverage on each product.

If the unit malfunctions, it must be returned to the factory for evaluation. OMEGA's Customer Service Department will issue an Authorized Return (AR) number immediately upon phone or written request. Upon examination by OMEGA, if the unit is found to be defective, it will be repaired or replaced at no charge. OMEGA's WARRANTY does not apply to defects resulting from any action of the purchaser, including but not limited to mishandling, improper interfacing, operation outside of design limits, improper repair, or unauthorized modification. This WARRANTY is VOID if the unit shows evidence of having been tampered with or shows evidence of having been damaged as a result of excessive corrosion; or current, heat, moisture or vibration; improper specification; misapplication; misuse or other operating conditions outside of OMEGA's control. Components which wear are not warranted, including but not limited to contact points, fuses, and triacs.

**OMEGA is pleased to offer suggestions on the use of its various products. However, OMEGA neither assumes responsibility for any omissions or errors nor assumes liability for any damages that result from the use of its products in accordance with information provided by OMEGA, either verbal or written. OMEGA warrants only that the parts manufactured by it will be as specified and free of defects. OMEGA MAKES NO OTHER WARRANTIES OR REPRESENTATIONS OF ANY KIND WHATSOEVER, EXPRESS OR IMPLIED, EXCEPT THAT OF TITLE, AND ALL IMPLIED WARRANTIES INCLUDING ANY WARRANTY OF MERCHANTABILITY AND FITNESS FOR A PARTICULAR PURPOSE ARE HEREBY DISCLAIMED. LIMITATION OF**

**LIABILITY: The remedies of purchaser set forth herein are exclusive, and the total liability of OMEGA with respect to this order, whether based on contract, warranty, negligence, indemnification, strict liability or otherwise, shall not exceed the purchase price of the component upon which liability is based. In no event shall OMEGA be liable for consequential, incidental or special damages.**

CONDITIONS: Equipment sold by OMEGA is not intended to be used, nor shall it be used: (1) as a "Basic Component" under 10 CFR 21 (NRC), used in or with any nuclear installation or activity; or (2) in medical applications or used on humans. Should any Product(s) be used in or with any nuclear installation or activity, medical application, used on humans, or misused in any way, OMEGA assumes no responsibility as set forth in our basic WARRANTY / DISCLAIMER language, and, additionally, purchaser will indemnify OMEGA and hold OMEGA harmless from any liability or damage whatsoever arising out of the use of the Product(s) in such a manner.

## RETURN REQUESTS/INQUIRIES

Direct all warranty and repair requests/inquiries to the OMEGA Customer Service Department. **BEFORE RETURNING ANY PRODUCT(S) TO OMEGA, PURCHASER MUST OBTAIN AN AUTHORIZED RETURN (AR) NUMBER FROM OMEGA'S CUSTOMER SERVICE DEPARTMENT (IN ORDER TO AVOID PROCESSING DELAYS).** The assigned AR number should then be marked on the outside of the return package and on any correspondence.

The purchaser is responsible for shipping charges, freight, insurance and proper packaging to prevent breakage in transit.

FOR **WARRANTY** RETURNS, please have the following information available **BEFORE** contacting OMEGA:

1. Purchase Order number under which the product was PURCHASED,
2. Model and serial number of the product under warranty, and
3. Repair instructions and/or specific problems relative to the product.

FOR **NON-WARRANTY** REPAIRS, consult OMEGA for current repair charges. Have the following information available **BEFORE** contacting OMEGA:

1. Purchase Order number to cover the COST of the repair,
2. Model and serial number of the product, and
3. Repair instructions and/or specific problems relative to the product.

OMEGA's policy is to make running changes, not model changes, whenever an improvement is possible. This affords our customers the latest in technology and engineering.

OMEGA is a registered trademark of OMEGA ENGINEERING, INC.

© Copyright 2004 OMEGA ENGINEERING, INC. All rights reserved. This document may not be copied, photocopied, reproduced, translated, or reduced to any electronic medium or machine-readable form, in whole or in part, without the prior written consent of OMEGA ENGINEERING, INC.

# Where Do I Find Everything I Need for Process Measurement and Control? **OMEGA...Of Course!**

*Shop online at [www.omega.com](http://www.omega.com)*

## **TEMPERATURE**

- Thermocouple, RTD & Thermistor Probes, Connectors, Panels & Assemblies
- Wire: Thermocouple, RTD & Thermistor
- Calibrators & Ice Point References
- Recorders, Controllers & Process Monitors
- Infrared Pyrometers

## **PRESSURE, STRAIN AND FORCE**

- Transducers & Strain Gages
- Load Cells & Pressure Gages
- Displacement Transducers
- Instrumentation & Accessories

## **FLOW/LEVEL**

- Rotameters, Gas Mass Flowmeters & Flow Computers
- Air Velocity Indicators
- Turbine/Paddlewheel Systems
- Totalizers & Batch Controllers

## **pH/CONDUCTIVITY**

- pH Electrodes, Testers & Accessories
- Benchtop/Laboratory Meters
- Controllers, Calibrators, Simulators & Pumps
- Industrial pH & Conductivity Equipment

## **DATA ACQUISITION**

- Data Acquisition & Engineering Software
- Communications-Based Acquisition Systems
- Plug-in Cards for Apple, IBM & Compatibles
- Datalogging Systems
- Recorders, Printers & Plotters

## **HEATERS**

- Heating Cable
- Cartridge & Strip Heaters
- Immersion & Band Heaters
- Flexible Heaters
- Laboratory Heaters

## **ENVIRONMENTAL MONITORING AND CONTROL**

- Metering & Control Instrumentation
- Refractometers
- Pumps & Tubing
- Air, Soil & Water Monitors
- Industrial Water & Wastewater Treatment
- pH, Conductivity & Dissolved Oxygen Instruments