

1 YEAR
WARRANTY

Ω OMEGA™ **User's Guide**

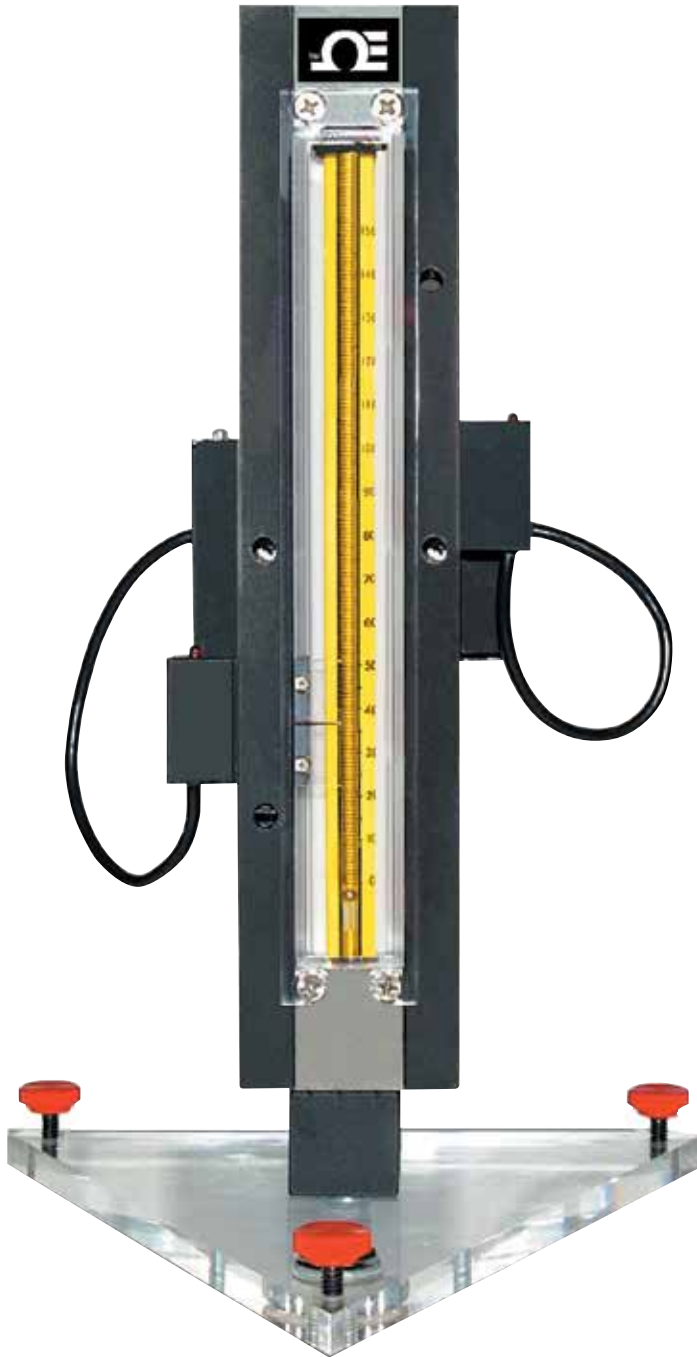

***Shop online at
omega.com***
e-mail: info@omega.com
***For latest product manuals:
www.omegamanual.info***

FLSW Series ROTAMETER WITH ALARM



omega.com info@omega.com

Servicing North America:

**U.S.A.
Headquarters:**

Omega Engineering, Inc.

Toll-Free: 1-800-826-6342 (USA & Canada only)

Customer Service: 1-800-622-2378 (USA & Canada only)

Engineering Service: 1-800-872-9436 (USA & Canada only)

Tel: (203) 359-1660

Fax: (203) 359-7700

e-mail: info@omega.com

For Other Locations Visit omega.com/worldwide

TABLE OF CONTENTS

1. UNPACKING the Optical Sensor Switch.	1
1.1 Inspect Package for External Damage	1
1.2 Unpack the Optical Sensor Switch	1
1.3 Packing List	1
1.4 Returning Merchandise for Repair	1
2. DESCRIPTION.	1
3. INSTALLATION.	2
3.1 Electrical Connections	2
4. SPECIFICATIONS.	4
5. CE Compliance	4
6. OPERATING INSTRUCTIONS.	5
6.1 Sensor alignment.	5
6.2 DIP Switch Configuration.	5
7. TROUBLESHOOTING.	6
7.1 Common Conditions.	6
7.2 Troubleshooting Guide	6
7.3 Technical Assistance.	6
APPENDIX 1 COMPONENT DIAGRAM.	8
APPENDIX 2 DIMENSIONAL DRAWINGS	9
APPENDIX 3 WARRANTY	10

1 UNPACKING THE Optical Sensor Switch

1.1 Inspect Package for External Damage

Your Optical Sensor Switch was carefully packed in a sturdy cardboard carton, with anti-static cushioning materials to withstand shipping shock. Upon receipt, inspect the package for possible external damage. In case of external damage to the package contact the shipping company immediately.

1.2 Unpack the Optical Sensor Switch

Open the carton carefully from the top and inspect for any sign of concealed shipping damage. Please keep all packing and notify Omega Customer Service of any damage.

When unpacking the instrument please make sure that you have all the items indicated on the Packing List. Please report any shortages promptly.

1.3 Packing List

	Quantity
Desired Flow Meter with Hi-Lo Sensors Installed	1
OSSM	1
Power Supply	Optional
Splitter	2
User's Guide	1

1.4 Returning Merchandise for Repair

Please contact the customer service representative at 1-800-826-6342 ext. 2208 for a Return Authorization Number (AR).

It is mandatory that any equipment returned for servicing be purged and neutralized of any dangerous contents including but not limited to toxic, bacterially infectious, corrosive or radioactive substances.

2. DESCRIPTION

The 150 mm Flow Meter with Hi-Lo Alarm Optical Sensor Switch is a non-invasive means for detection of a HI or LOW flow. This sensor is ideal for signaling an alarm, cutoff valve, or other device when the float passes the detector.

The Hi-Lo Optical Sensor Switch consists of the OSSM module and two self-contained mini-slim photoelectric sensors (Thrubeam type). Every sensor has a transmitter and receiver. Two sets of sensors are mounted on two solid carriers on opposite sides of the flow tube. The float inside the flow tube is detected as it passes across the beam of light. The sensors can be used to detect the float passage beyond the set point of the sensor and can also be set to monitor the float position at a specific level, signaling when the float is outside of the range of the sensor light beam.

3. INSTALLATION

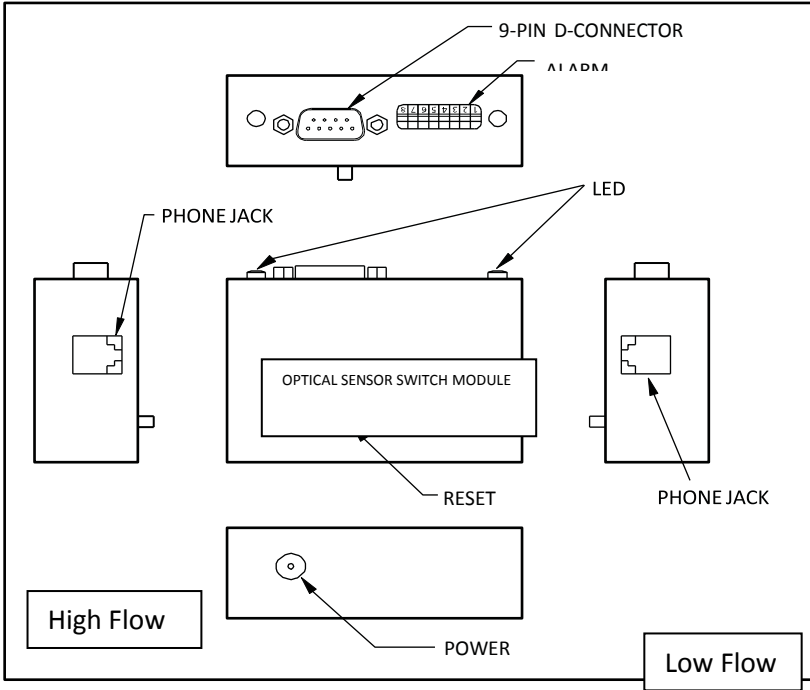

Figure 1: OSSM module

3. Electrical Connections

The Optical Sensor Switch gets a power through the OSSM module. The module could be powered up either by a +12+15 VDC power supply with a minimum current rating of 250 mA, or by the 9-pin D-connector (DB9M) (Fig. 1) for momentary or latch operations.



SUPPLYING DC POWER TO THE POWER JACK AND THE "D" CONNECTOR AT THE SAME TIME WILL DAMAGE THE METER. DC POWER JACK POLARITY IS CENTER POSITIVE.



WARNING: DO NOT CONNECT POWER SUPPLY WITH MORE THAN 15VDC VOLTAGE

- 3.1. Insert the LOW flow sensor's plugs into the splitter, then the splitter's plug into the module's phone jack #1 (Fig. 1).
- 3.2. Insert the HIGH flow sensor's plugs into the splitter, then the

splitter's plug into the module's phone jack #2 (Fig. 1).

3.3 Connect the power supply through the power jack (Fig. 1).

Or

Attach the 9-pin D-connector to the module (fig. 1 & 2).

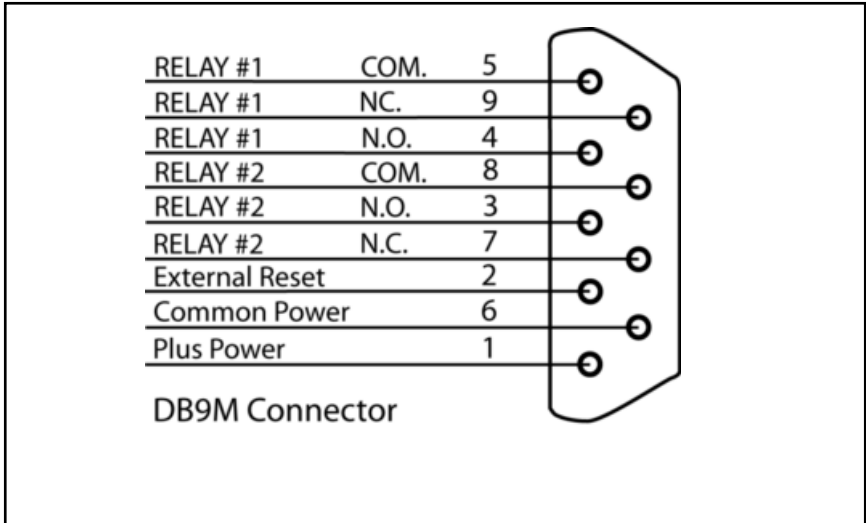

Figure 2: 9 Pin "D" Connector Configuration.

During the initial power up of the Optical Sensor Switch with no flow conditions the red and green LED on the module will be "On". This is an indication that power is on and the sensors are ready for operation. Both sensors will have 2 green lights "On" from each side of the flow meter.



Important notes:

In general, "D" Connector numbering patterns are standardized. There are, however, some connectors with nonconforming patterns and the numbering sequence on your mating connector may or may not coincide with the numbering sequence shown in our pin configuration table above. It is imperative that you match the appropriate wires in accordance with the correct sequence regardless of the particular numbers displayed on your mating connector.

Make sure power is OFF when connecting or disconnecting any cables in the system. The power input is protected by a 600 mA (medium time-lag) resettable fuse. If a shorting condition or polarity reversal occurs, the fuse will cut power to the valve circuit. Disconnect the power to the unit; remove the faulty condition, and reconnect the power. The fuse will reset once the faulty condition has been removed.

Use of the Optical Sensor Switch in a manner other than that specified in this manual may impair the protection provided by the equipment.

4. SPECIFICATIONS

MATERIALS OF CONSTRUCTION

END BLOCKS:	Aluminum or 316 Stainless Steel.
ELASTOMERS:	Buna & Viton (Aluminum), Viton (316 SS).
FLOW TUBE:	Borosilicate Glass.
POWER INPUT:	+ 12+15 VDC. Minimum current rating 250 mA peak to peak max 100mV.
POWER CONSUMPTION:	Less than 200 mA.
ACCURACY:	+/- 2% of full scale.
REPEATABILITY:	0.5% of full scale.
AMBIENT TEMPERATURE:	20-55 deg. C.
RESPONSE TIME:	0.5 milliseconds.
LIGHT IMMUNITY:	4 Element, point light source, red LED 650 nm
DRY CONTACT CLOSURES:	2 normally open, and normally closed relays (1A, 30VDC max.)
ALARM:	70 dB audible buzzer and/or visual LED
ALARM OPTIONS:	High, Low, or High/Low.
BUZZER:	User configurable, momentary or latch.
RESET:	Reset button or remote through "D"-connector to disable relay or buzzer (remote Reset is TTL compatible active Low).

Environmental (per IEC 664): Installation Level II; Pollution Degree

5. CE Compliance

Any model Optical Sensor Switch bearing a CE marking on it, is in compliance with the below stated test standards currently accepted.

EMC Compliance with 2014/108/EC:

Radiated Emmission: EN55011:2009/A1:2010

Immunity Standard: EN61000-4-3:2006/A1:2008+A2:2010

Low-voltage switchgear and controlgear: EN 60947-5-2:2007

RoHS Directive: 2011/65/EU

6. OPERATING INSTRUCTIONS

6.1. Sensor Alignments

Two sensors' carriers can be set in any position along the flow meter tube.



WARNING: Do not install the sensors closer than 1/2" (10 mm) from one to another. Doing so may trigger a false alarm condition.

To set up the switches position:

- Loosen the 2 red thumbscrews;
- Slide the switch carrier to the desired position;
- Tighten the thumbscrews.

Stable operation indicator (green LED) turns on with a stable incoming beam and with a stable blocked light. Output indicator (orange LED) turns on when the beam from emitter is blocked by the float.

Each Optical Sensor Switch is shipped from the factory with the sensors aligned and does not require additional adjustment of the focus distance even if the flow tube was replaced or reinstalled (see p. 6.2).

6.2. DIP switch configuration

The DIP switch, located near the 9-pin D-connector can be used to set up custom's settings separately for High and Low alarm.

In order to activate the sensor's alarm the corresponding switch has to be installed in the "On" position on the Configuration DIP switch (see Fig. 3). Each sensor (High or Low) can be separately set for Momentary or Latch operation. In addition the Relay and Buzzer can be configured individually.

As an example, if the SW1 is set to "On": the High flow alarming (latching mode) is active, then the green LED (on left side of the D-connector) and relay will be energized in the LATCH mode. They will stay in the energized state without any conditions (even if the flow rate changes and the sensor have become inactive) until the RESET button is pressed or external RESET TTL signal is applied. If momentary mode is set (DIP switch SW3 is set to "On") the relay and green LED will be energized only when the High flow sensor is active (Alarm Condition). The same is true for the Buzzer settings.

All Switches "Off" position—Alarm is disabled (LED, Relays and Buzzer).

ALARM DIP SWITCH CONFIGURATION		
“On”- pressed down	“Off”-raised up	
HIGH ALARM	LOW ALARM	ACTION WHEN SWITCH IS “ON”
SW1	SW5	LED and Relay are On (LATCH)
SW2	SW6	BUZZER is On (LATCH)
SW3	SW7	LED and Relay are On momentary (FOLLOW SENSOR)
SW4	SW8	BUZZER is On momentary (FOLLOW SENSOR)

Figure 3: Optical Sensor DIP Switch Configuration.

7. TROUBLESHOOTING

7.1. Common Conditions

Your Optical Sensor Switch was thoroughly checked at numerous quality control points during and after manufacturing and assembly operations. It was carefully packed to prevent damage during shipment. Should you feel that the instrument is not functioning properly please check for the following common conditions first:

Are all cables connected correctly?

Are there any leaks in the installation?

Is the power supply correctly selected according to requirements? When several devices are used a power supply with appropriate current rating should be selected.

Were the connector pinouts matched properly? When interchanging with other manufacturers' equipment, cables and connectors must be carefully wired for correct pin configurations.

7.2. Troubleshooting Guide

NO	INDICATION	LIKELY REASON	SOLUTION
1	No green LED lights on sensors.	Power supply off.	Check connection of the power supply.
		No connections between sensors and splitter; no connections between splitter and OSSM	Check connection between sensors, splitters & the OSSM.
2	Buzzer or Relay does not work.	Wrong configuration of the DIP switch.	Make correct configuration of the DIP switch according to Figure 3.
		Pc board defect.	Return to factory for replacement.
3	The sensor does not react on passing float (no orange LED)	Sensor's carrier is not locked into the position	Tighten the red thumbscrews

7.3. Technical Assistance

Repair personnel. Please call our Technical Assistance at 800 872 9436 ext. 2298. Please have your Serial Number and Model Number ready when you call.

APPENDIX 1

COMPONENTS DIAGRAM

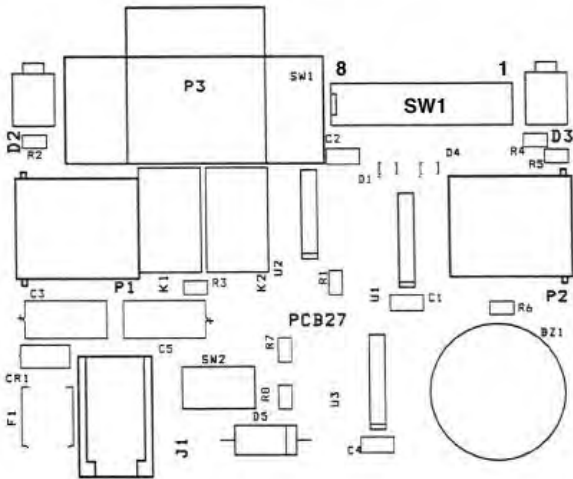

APPENDIX 2

DIMENSIONAL DRAWINGS

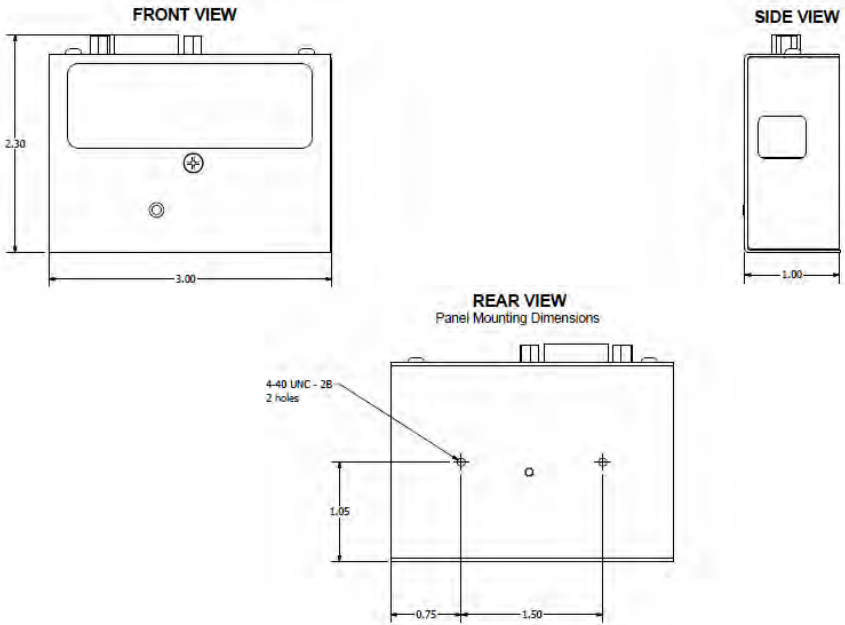

NOTES: Omega reserves the right to change designs and dimensions at its sole discretion at any time without notice. For certified dimensions please contact Omega.

WARRANTY/DISCLAIMER

OMEGA ENGINEERING, INC. warrants this unit to be free of defects in materials and workmanship for a period of **13 months** from date of purchase. OMEGA's WARRANTY adds an additional one (1) month grace period to the normal **one (1) year product warranty** to cover handling and shipping time. This ensures that OMEGA's customers receive maximum coverage on each product.

If the unit malfunctions, it must be returned to the factory for evaluation. OMEGA's Customer Service Department will issue an Authorized Return (AR) number immediately upon phone or written request. Upon examination by OMEGA, if the unit is found to be defective, it will be repaired or replaced at no charge. OMEGA's WARRANTY does not apply to defects resulting from any action of the purchaser, including but not limited to mishandling, improper interfacing, operation outside of design limits, improper repair, or unauthorized modification. This WARRANTY is VOID if the unit shows evidence of having been tampered with or shows evidence of having been damaged as a result of excessive corrosion; or current, heat, moisture or vibration; improper specification; misapplication; misuse or other operating conditions outside of OMEGA's control. Components in which wear is not warranted, include but are not limited to contact points, fuses, and triacs.

OMEGA is pleased to offer suggestions on the use of its various products. However, OMEGA neither assumes responsibility for any omissions or errors nor assumes liability for any damages that result from the use of its products in accordance with information provided by OMEGA, either verbal or written. OMEGA warrants only that the parts manufactured by the company will be as specified and free of defects. OMEGA MAKES NO OTHER WARRANTIES OR REPRESENTATIONS OF ANY KIND WHATSOEVER, EXPRESSED OR IMPLIED, EXCEPT THAT OF TITLE, AND ALL IMPLIED WARRANTIES INCLUDING ANY WARRANTY OF MERCHANTABILITY AND FITNESS FOR A PARTICULAR PURPOSE ARE HEREBY DISCLAIMED. LIMITATION OF LIABILITY: The remedies of purchaser set forth herein are exclusive, and the total liability of OMEGA with respect to this order, whether based on contract, warranty, negligence, indemnification, strict liability or otherwise, shall not exceed the purchase price of the component upon which liability is based. In no event shall OMEGA be liable for consequential, incidental or special damages.

CONDITIONS: Equipment sold by OMEGA is not intended to be used, nor shall it be used: (1) as a "Basic Component" under 10 CFR 21 (NRC), used in or with any nuclear installation or activity; or (2) in medical applications or used on humans. Should any Product(s) be used in or with any nuclear installation or activity, medical application, used on humans, or misused in any way, OMEGA assumes no responsibility as set forth in our basic WARRANTY/DISCLAIMER language, and, additionally, purchaser will indemnify OMEGA and hold OMEGA harmless from any liability or damage whatsoever arising out of the use of the Product(s) in such a manner.

RETURN REQUESTS/INQUIRIES

Direct all warranty and repair requests/inquiries to the OMEGA Customer Service Department. BEFORE RETURNING ANY PRODUCT(S) TO OMEGA, PURCHASER MUST OBTAIN AN AUTHORIZED RETURN (AR) NUMBER FROM OMEGA'S CUSTOMER SERVICE DEPARTMENT (IN ORDER TO AVOID PROCESSING DELAYS). The assigned AR number should then be marked on the outside of the return package and on any correspondence.

The purchaser is responsible for shipping charges, freight, insurance and proper packaging to prevent breakage in transit.

FOR **WARRANTY** RETURNS, please have the following information available BEFORE contacting OMEGA:

1. Purchase Order number under which the product was PURCHASED,
2. Model and serial number of the product under warranty, and
3. Repair instructions and/or specific problems relative to the product.

FOR **NON-WARRANTY** REPAIRS, consult OMEGA for current repair charges. Have the following information available BEFORE contacting OMEGA:

1. Purchase Order number to cover the COST of the repair,
2. Model and serial number of the product, and
3. Repair instructions and/or specific problems relative to the product.

OMEGA's policy is to make running changes, not model changes, whenever an improvement is possible. This affords our customers the latest in technology and engineering.

OMEGA is a trademark of OMEGA ENGINEERING, INC.

© Copyright 2018 OMEGA ENGINEERING, INC. All rights reserved. This document may not be copied, photocopied, reproduced, translated, or reduced to any electronic medium or machine-readable form, in whole or in part, without the prior written consent of OMEGA ENGINEERING, INC.

Where Do I Find Everything I Need for Process Measurement and Control? **OMEGA...Of Course!** *Shop online at omega.com*

TEMPERATURE

- ☑ Thermocouple, RTD & Thermistor Probes, Connectors, Panels & Assemblies
- ☑ Wire: Thermocouple, RTD & Thermistor
- ☑ Calibrators & Ice Point References
- ☑ Recorders, Controllers & Process Monitors
- ☑ Infrared Pyrometers

PRESSURE, STRAIN AND FORCE

- ☑ Transducers & Strain Gages
- ☑ Load Cells & Pressure Gages
- ☑ Displacement Transducers
- ☑ Instrumentation & Accessories

FLOW/LEVEL

- ☑ Rotameters, Gas Mass Flowmeters & Flow Computers
- ☑ Air Velocity Indicators
- ☑ Turbine/Paddlewheel Systems
- ☑ Totalizers & Batch Controllers

pH/CONDUCTIVITY

- ☑ pH Electrodes, Testers & Accessories
- ☑ Benchtop/Laboratory Meters
- ☑ Controllers, Calibrators, Simulators & Pumps
- ☑ Industrial pH & Conductivity Equipment

DATA ACQUISITION

- ☑ Communications-Based Acquisition Systems
- ☑ Data Logging Systems
- ☑ Wireless Sensors, Transmitters, & Receivers
- ☑ Signal Conditioners
- ☑ Data Acquisition Software

HEATERS

- ☑ Heating Cable
- ☑ Cartridge & Strip Heaters
- ☑ Immersion & Band Heaters
- ☑ Flexible Heaters
- ☑ Laboratory Heaters

ENVIRONMENTAL MONITORING AND CONTROL

- ☑ Metering & Control Instrumentation
- ☑ Refractometers
- ☑ Pumps & Tubing
- ☑ Air, Soil & Water Monitors
- ☑ Industrial Water & Wastewater Treatment
- ☑ pH, Conductivity & Dissolved Oxygen Instruments