

Model: 400B-CV and 402B-CV

## **TABLE OF CONTENTS**

### **SECTION 1**

#### **1.1 GENERAL DESCRIPTION**

#### **1.2 OPTIONS**

### **SECTION 2 SPECIFICATIONS**

### **SECTION 3 INSTALLATION**

#### **3.1 UNPACKING/ REPACKING**

#### **3.2 CONFIGURING**

#### **3.3 MOUNTING**

#### **3.4 WIRING**

### **SECTION 4 CALIBRATION AND SCALING**

**Note:** This manual is for the enhanced version of the Model 400 and 402 units. For models 400 and 402 before 3-2002 with serial numbers without the letter “N” please refer to manual part number M0035.

M3778/0602

# **SECTION 1            DESCRIPTION**

## **1.1 DESCRIPTION.**

This manual contains installation, operation, and calibration information for Series 400 digital process indicators. These solid-state instruments are designed for accurate, reliable, and trouble-free display of voltage or milliamps. All instruments feature a dual-slope A/D converter digital linearization, and a large 0.8" (20mm) easy-to-read 4-digit LED display. Input voltage or current can be scaled to Engineering units from -999 to +9999 counts.

The displays are in-line, uniplanar, 7-segment red LEDs, easy to read through the front Plexiglas panel. A -OL displayed on the read-out indicates a negative polarity overload. Positive readings are inferred (no sign displayed). OL indicate a positive overload condition. All units operate from 100, 120, 220, or 240VAC 50-60 Hz power source. A power connector and ground screw for shield are located at the rear of the instrument. The instrument case is made of solid die-cast aluminum, which is rugged enough to withstand the most hostile environments. It is designed to mount in a panel. The optional rack mounts can accommodate up to 3 units. Bench mount option 400-W5 provides for convenient bench top use.

## Multiple Input Options, Models 402 and 405

Model 402 can accept five inputs of the same input either voltage or current. Buttons numbered 1-5 are located below display. Individual input is selected by pressing appropriate button.

The Model 405A provide 10-switchable inputs to a single indicator. Model 405A are housed in the same rugged case design as the basic indicator. Each may be rack-mounted beside another 405A or indicator. Pushbuttons are in two rows of five and are numbered 1-10, 11-20, etc. Each row is interlocked to prevent simultaneous input selection.

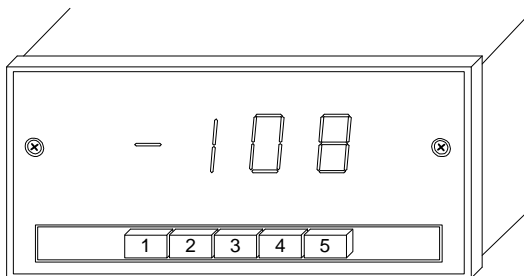

Model 402

Figure 2. Input Sensor Connections 402A

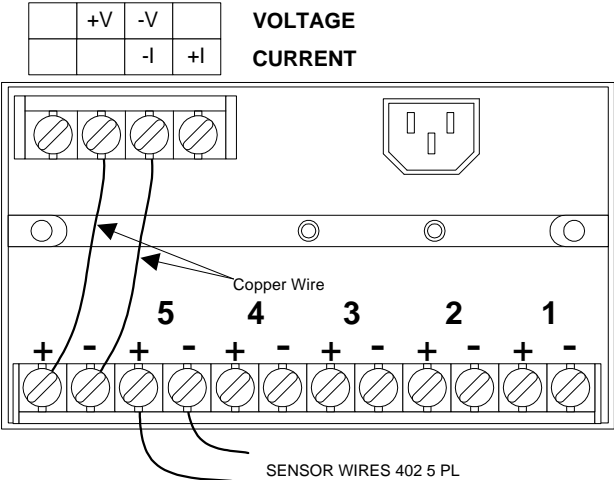

## USING THE EXTERNAL SWITCHING UNITS (MODELS 405)

The External Switching Units provide 10 switchable inputs to a single indicator. Inputs are selected by two rows of front panel pushbuttons labeled 1-10. (For special numbering contact factory). Pressing a particular pushbutton selects that input point for display. Each row of pushbuttons is interlocked so that only one pushbutton within that row is selected at once time.

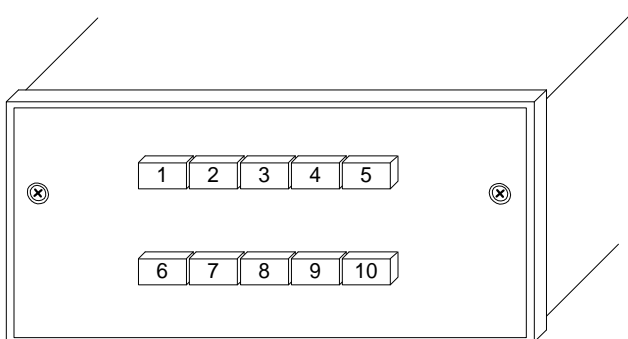

Model 405

## SECTION 2      SPECIFICATIONS

### **Input Range:**

mA: 0-20mADC

Voltage: 0-10 VDC

### **Sensitivity:**

Maximum: 200uV/count; 0.4uA/count

Minimum: 1 count

### **Input Impedance:**

MA: 5 $\Omega$

Voltage: > 1M $\Omega$

### **A/D Read Rate:**

2 per second nominal

### **Power:**

115VAC  $\pm$  10%, 50-60 Hz

230VAC  $\pm$  10%, 50-60 Hz

30mA Max input current @ 115VAC

### **Operating Ranges:**

Temperature: 0 to 50°C

Relative Humidity: 10-80% RH non-condensing

**Storage Range:**

-40 to 65°C

**Size:**

Case: 144mm W x 72mm H x 173 mm D  
(5.768" x 2.84" x 6.82")

**Maximum Weight:**

1.7 kg / 2.5 lb

**Panel cutout:**

68mm H x 138mm W  
2.68" H x 5.44" W

**PERFORMANCE SPECIFICATIONS****Reference Operating Conditions (ROC):**

±10% line voltage  
23 ±2 °C ambient temperature  
<80% RH non- condensing

**Accuracy (at ROC):**

0.02% RDG +/- 1 count

## **Noise Rejection:**

NMRR:  $\geq 60$  db @ 50/60 Hz,  $\pm 0.1$ Hz

CMRR:  $\geq 120$  db @ 50/60 Hz,  $\pm 0.1$ Hz with  $250\Omega$  unbalance.

## **Overload Protection:**

Power Lead to ground: 1500VDC or AC RMS

Voltage: Up to 250VDC or VAC for 1 minute, V+ to V-

mA: Up to 150mADC mAAC for 1 minute, +I to -I

## **Stability With Temperature:**

Zero:  $1\mu\text{V}/^\circ\text{C}$

Span: 0.01% rdg / $^\circ\text{C}$

## **Stability With Time:**

10 counts/year max

## **Repeatability:**

$\pm 1$  count



## **SECTION 3    INSTALLATION**

### **3.1 UNPACKING / REPACKING**

The Series 400 indicators are rugged, but they must be properly packed. Instruments are shipped in a custom-designed carton for shipping, but damage may occur. When you receive your instrument, look for evidence of transit damage. If damage is found, ask the carrier to prepare a Damage Inspection Report and notify our Instrument Repair Department immediately. If your instrument has arrived in good condition, you may perform the functional test described in 3.2.2 to verify proper operation.

### **REPACKING AND RETURNING THE INSTRUMENT**

The original shipping container should be retained in case the instrument must be returned for repair or modification. When returning an instrument for any reason, advise us of the model number, serial number, your name, billing address, shipping address, phone number and a description of the problem. This information will enable our Instrument Repair Department to expedite the return of your instrument. Instruments being returned to the factory are required to be shipped freight prepaid.

Instruments being returned for warranty service must also refer to the original purchase date on packing lists and

purchase orders. Instruments without this information will be processed as a non-warranty repair at current service rates.

If the original shipping container has been discarded, pack your instrument for shipping as follows:

Select a strong cardboard box of sufficient size to allow an inch of packing material around all sides of the unit.

- a. Ensure that the printed circuit boards are secured and front and rear panels are firmly in place.
- b. Wrap the instrument in plastic or strong paper. Place it centrally in the shipping container, and pack poly foam, bubble pack, or rubberized hair around all six sides of the instrument.
- c. Tape the carton flaps securely and label the container "FRAGILE, DELICATE INSTRUMENT". Ship the instrument, freight prepaid (do not ship by U.S mail)

## **Input Voltage Selection (requires removal)**

Input voltage 115 or 220VAC, is selectable by cutting and adding jumpers on the main board as shown on the next page. Locate JP18 on the printed circuit board. Cut and make connection as shown on table depending on input voltage.

## **REMOVING THE ELECTRONICS FROM THE ENCLOSURE**

- 1- Make sure to disconnect power from the unit
- 2- Remove the three back cover screws and remove the rear panel
- 3- Remove the screw located directly above the AC plug
- 4- Remove two screws from the front panel lens and remove lens
- 5- Remove two screws from the front holding the Board assembly and pull it out of the case.
- 6- Reinstall the assembly when finished.

<b>Input Voltage</b>	<b>JP18</b>
<b>120 VAC</b>	<b>1-2, 4-5</b>
<b>220 VAC</b>	<b>2-3, 5-6</b>

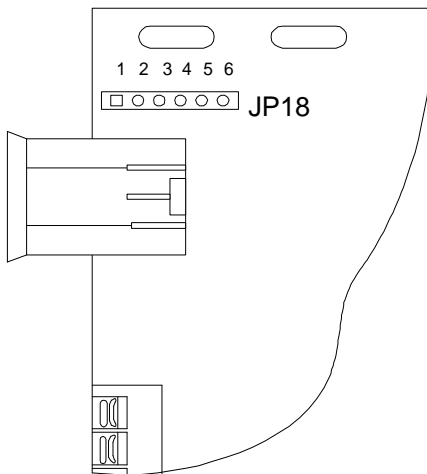

### 3.3 INSTALLATION

#### Panel Mounting

Panel mounting hardware is supplied standard with the instrument. The instrument bezel butts against the front of the mounting panel; the mounting bracket fits over the instrument rear panel. The bracket screws force it against the rear of the mounting panel, locking the instrument in place. Panel cutout dimensions are 68mm x 138mm (2.68" x 5.44").

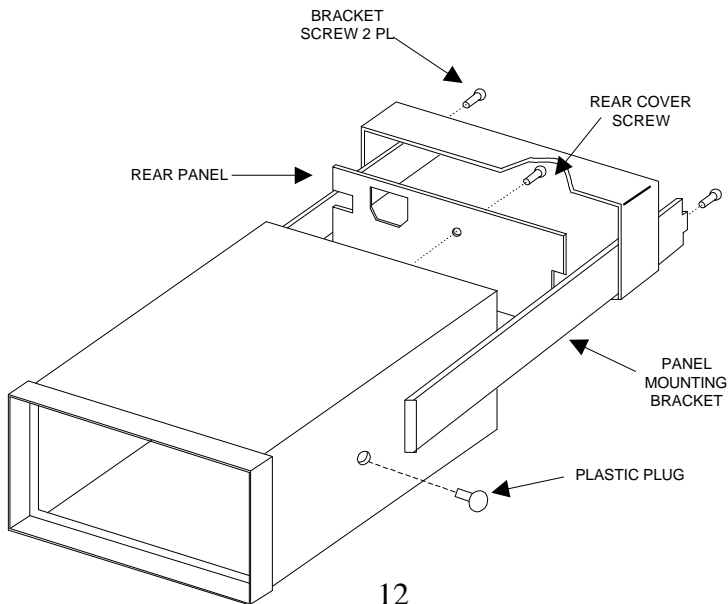

### 3.4 WIRING THE INSTRUMENT.

All signal input connections are made to the instrument using screw terminals. To gain access to the recessed terminal strip, the rear cover panel must be removed. The four signal input terminals are located in the upper-left corner, and are labeled +I, +V, -V, and -I.

#### REMOVE THE POWER CORD BEFORE WIRING

#### Basic Single Channel Wiring

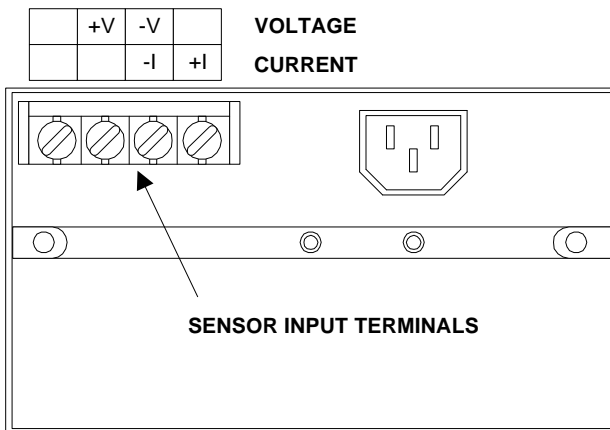

# Model 402 Switching Unit Wiring

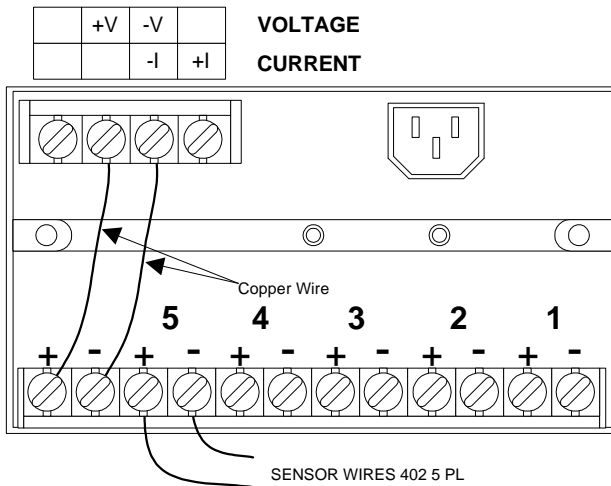

## **SECTION 4**

### **CALIBRATION AND SCALING**

#### **4.1 APPLYING POWER TO THE INSTRUMENT**

Power is applied to the instrument as long as the instrument is plugged into an active source. To remove power, unplug the power cord from the instrument or AC outlet.

To eliminate shock hazard or possible instrument damage, always remove the power cord either from the instrument or power source before configuring the indicator.

#### **4.2 Selecting mA or Volts Input Mode**

To select between mA or Volts input mode, remove the front panel lens to gain access to the display board. Behind the display is a DIP switch used to set the indicator's input measuring mode. See the drawing on the following page showing DIP switch location as well as the location of the SET and ENTER scaling buttons.



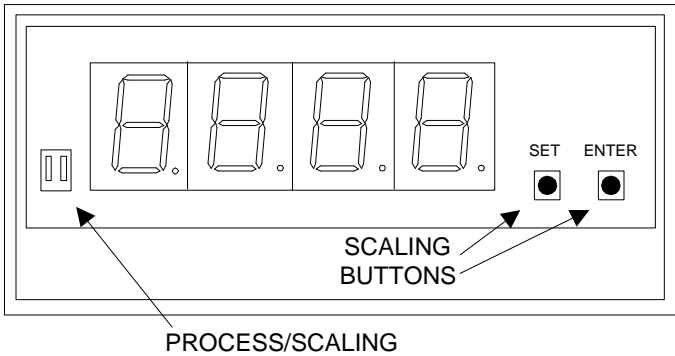

PUSH DOWN HERE  
FOR PROCESS  
MEASURING MODE  
DISPLAY

PUSH DOWN HERE TO  
CONFIGURE  
INSTRUMENT FOR mA  
INPUT

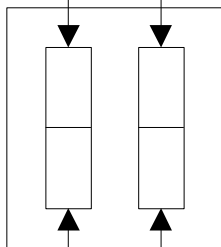

DIP SWITCH

PUSH DOWN HERE  
FOR SCALING MODE

PUSH DOWN HERE TO  
CONFIGURE  
INSTRUMENT FOR  
VOLTAGE INPUT

## Calibrating and Scaling the Indicator

Scaling the indicator to display in your desired engineering units requires simulation of two different input VALUES (typically the lowest input and highest input) and using the two “SET” and “ENTER” buttons to scroll the digital display.

With the front lens removed and the mA/V switch  
In the position compatible with your input...

Step 1: Hook up a DC milliamp or Voltage source Calibrator or actual transducer, capable of supplying a low scale and full scale input, to the appropriate rear panel screw terminals on the indicator.

Step 2: Set the “PROCESS/SCALING” switch to the SCALING position. The word “Lo” will appear on the display.

Step 3: a) Simulate the low scale input (e.g. 4 mA)

b) Push the “ENTER” button.

c) Use the “SET” button to change the value of the flashing digit. When the flashing digit is correct, push the “ENTER” button. The flashing digit will

now move to the next right hand digit. Continue until all digits are correct with the right most digit still flashing.

- d) Push both “SET” and “ENTER” buttons at the same time to program in this scale factor. In other words, when the indicator receives a process input signal identical to the simulated (calibration) one it will display the same value shown now. (e.g. 4mA=0000)

NOTE: While the indicators calibrating itself “oo” will appear in the display. After a few seconds it will return to display “Hi” (go to step 4) or “ERR” (see error message table).

Step 4: With “Hi” displayed change the input to simulate +Full scale (High e.g. 20mA).

Step 5: Repeat steps as shown in Steps 3b, 3c, 3d changing the digits to represent the Full Scale desired display (e.g. 7500). When complete, the indicator will then go to the decimal point position.

Step 6: With decimal points displayed...

- a) Push "SET" button until desired position is displayed
- b) Push "SET" and "ENTER" buttons at the same time to program into memory

Step 7: Return the "PROCESS/SCALING" switch to the PROCESS position. Replace the front lens. Remove the calibrator from the input terminals.

#### NOTES:

- 1) Pushing both the SET and ENTER buttons at the same time always causes the indicator to recalibrate itself to the given input at that moment. As a protective measure, if scaling changes are made and not terminated this way no recalibration will occur, previous values will remain.
- 2) As a further protective measure, the "SET" and "ENTER" buttons are not functional unless the PROCESS/SCALING switch is in the SCALING position.

# Button Function Legend

Use "SET" key to change value of flashing digit or decimal point

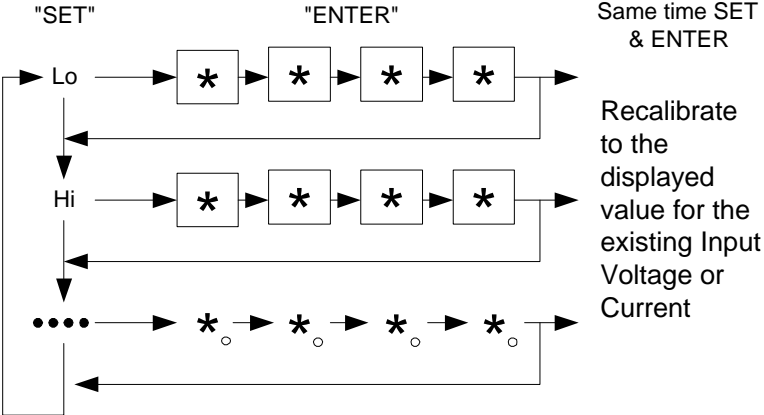

## ERROR MESSAGE TABLE

Message Displayed	DURING CALIBRATION/ SCALING MODE		DURING NORMAL PROCESS MEASURING MODE	
	CAUSE	CURE	CAUSE	CURE
Err1	Slope error Same values entered for both Hi and Lo	"Lo" and "Hi" values must be different. Push "set" button and re-enter for "Lo" and "Hi" values	N/A	
Err2	Slope error. Too many display counts for too little input	Push "SET" button. Reduce number of counts for given input.	N/A	
OL-OL	Overloaded input or display. Input exceeds specification.	Check input voltage or current. Must be within 0-10 VDC 0-20mA	Input exceeds maximum specifications or display is beyond -999 or 9999	Check input voltage or current for over range or open circuit
----	Internal A/D overload	Turn power off, wait 25 seconds, and turn power on again.	Internal A/D overload	Turn power off, wait 25 seconds, and turn power on again.