

1 YEAR
WARRANTY



Ω OMEGA® User's Guide



Shop online at
omega.comSM

e-mail: info@omega.com
For latest product manuals:
www.omegamanual.info



PCL1000 **Multi-Function Calibrator**



omega.com info@omega.com

Servicing North America:

U.S.A.

Headquarters:

OMEGA Engineering, Inc.

Toll-Free: 1-800-826-6342 (USA & Canada only)

Customer Service: 1-800-622-2378 (USA & Canada only)

Engineering Service: 1-800-872-9436 (USA & Canada only)

Tel: (203) 359-1660

Fax: (203) 359-7700

e-mail: info@omega.com

For Other Locations Visit omega.com/worldwide

Table of Contents

1. Introduction	
2. Quick Start Instructions	
A. Key Functions	4
B. Setpoints	4
3. Connection Diagrams & Instructions	
A. Measuring High Voltage AC or DC	6
B. Measuring Low Voltage and Frequency	6
C. Measuring Current	7
D. Sourcing Current	7
E. Simulating Current	8
F. Sourcing Voltage/ Resistance/Frequency	8
G. Sourcing a Thermocouple Signal	9
H. Measuring Temperature Using a Thermocouple	9
I. Measuring Resistance (RTDs)	9
J. Sourcing Resistance (RTDs)	10
4. Maintenance	
A. Power Requirements	11
B. Calibration	11
5. Specifications	12

PCL1000

1. Introduction

The PCL1000 is designed to be a versatile, easy to use multi-function calibrator with a simple user interface. The following instructions will allow the user to begin simple calibration tasks by learning the basic operation of the keys and their functions.

1.1 Customer Service

OMEGA Engineering

Tel: (203) 359-1660

Fax: (203) 359-7811

www.omega.com

email: cservice@omega.com

1.2 Unpacking

Remove the packing list and verify that all equipment has been received. If there are any questions about the shipment please call OMEGA at 1-800-826-6342. When the shipment is received inspect the container and equipment for any signs of damage. Note any evidence of rough handling in transit. Immediately report any damage to the shipping agent.

Note : The carrier will not honor any claims unless all shipping material is saved for their examination. After examining and removing contents, save packing material and carton in the event reshipment is necessary.

1.3 Safety information

Symbols Used

The following table lists the International Electrical Symbols. Some or all of these symbols may be used on the instrument or in this manual.

Symbol	Description
	AC (Alternating Current)
	AC-DC
	Battery
	CE Complies with European Union Directives
	DC
	Double Insulated
	Electric Shock
	Fuse
	PE Ground
	Hot Surface (Burn Hazard)
	Read the User's Manual (Important Information)
	Off
	On

The following definitions apply to the terms “Warning” and “Caution”.

- “Warning” identifies conditions and actions that may pose hazards to the user.
- “Caution” identifies conditions and actions that may damage the instrument being used.

Use the calibrator only as specified in this manual, otherwise injury and damage to the calibrator may occur.

 **Warning**

To avoid possible electric shock or personal injury:

- Do not apply more than the rated voltage. See specifications for supported ranges.
- Follow all equipment safety procedures.
- Do not use the calibrator if it is damaged. Before you use the calibrator, inspect the case. Look for cracks or missing plastic. Pay particular attention to the insulation surrounding the connectors.
- Select the proper function and range for your measurement.
- Make sure the battery cover is closed and latched before you operate the calibrator.
- Remove test leads from the calibrator before you open the battery door.
- Inspect the test leads for damaged insulation or exposed metal.
- When using the probes, keep your fingers away from the probe contacts. Keep your fingers behind the finger guards on the test leads.
- Do not use the calibrator if it operates abnormally. Protection may be impaired. When in doubt, have the calibrator serviced.
- Do not operate the calibrator around explosive gas, vapor, or dust.
- Disconnect test leads before changing to another measure or source function.
- When servicing the calibrator, use only specified replacement parts.
- To avoid false readings, which could lead to possible electric shock or personal injury, replace the battery as soon as the battery indicator appears.

 **Caution**

To avoid possible damage to calibrator or to equipment under test:

- Use the proper jacks, function, and range for your measurement or sourcing application.

2. Quick Start Instructions

A. Key Functions

Key	Function
Input/Output	Toggles the function selected from measurement mode to source mode.
V/mA/Hz	Selects between volts, milliamps, and frequency modes
TC/RTD	Selects between temperature modes either T/C or RTD. Ohms and mV ranges are also included in these functions.
Ranges/Units	This key toggles through all the ranges for a chosen function. Example: If T/C mode is selected the Range key toggles through the ranges J, K, T, E, etc.
0-9 keys	These keys allow a user to enter an output value. Example: to output 20 mA select mA output and Press the “2” key then the “0” key followed by the “ENTER” key.
Arrow ↑ ↓	These keys allow small changes to be made to an output value. Press either the up or the down arrow key to set the value as desired.
CE	The clear entry key allows the user to clear a value before the enter key is pressed.
Shift	This key has a blue text color and acts as a second function key to all keys that have an associated second function. Features such as setpoints, °F/°C, backlight and external pressure module activation all use the Shift key.

B. Setpoints

1. Storing Setpoints

The setpoint mode allows up to 9 setpoints to be stored in non-volatile memory for each range. The procedure is as follows:

- Set the output to the desired value.
- Press shift followed by the “SET” key.
- Choose the desired setpoint storage location by pressing a key (1-9).
- Enter a new value and repeat steps 1 thru 3 as needed, up to 9 setpoints for each range can be stored.

2. Recalling Setpoints

- To recall a setpoint, press shift followed by the “SPT” key.
- You will be prompted to enter the number of the desired setpoint location stored previously.
- Press the desired location number and the unit will go to that output.

3. Automated Stepping

The PCL1000 can auto-step through some or all of the stored setpoints for a given range. The procedure is as follows:

- a. Press “Shift” followed by auto.
- b. “Auto SPT ?” will appear. Enter the ending setpoint location.
Example: if you have all 9 setpoints stored but only want to step through the first 3 then enter “3” for this question.
- c. The next screen prompts you to enter the dwell time from 5 to 500 seconds. Simply enter a number in that range. Then press the “Enter” key.
- d. Auto-step will begin.
- e. To exit auto-step press “CE” key or enter a value.

4. Manual Stepping

The PCL1000 can be manually stepped through all or some of the stored setpoints. The procedure is as follows:

- a. Press “Shift” followed by “Man”.
- b. Using the arrow keys, toggle up and down through the stored setpoints.
- c. To exit press CE or simply enter a new output value.

5. Pressure Module Interface

The PCL1000 has the capability to interface with a family of pressure modules available from OMEGA. The procedure is as follows:

- a. Connect the pressure module to the 15 pin “D” connector on top of the PCL1000.
- b. Press “Shift” followed by the “” key.
- c. Always zero the pressure module before starting a calibration.
Press “Shift” followed by the “Zero” key.

Note: More detailed information can be found with the instructions packaged with each module.

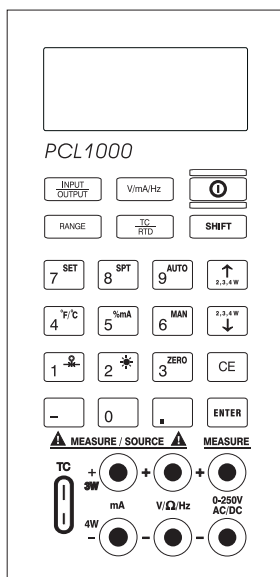

3. Connection Diagrams & Instructions

A. Measuring High Voltage AC or DC

1. Select the Voltage Input Mode. Use the "Range" key to select either AC or DC input.
2. Connect the device to be measured as shown in Figure 1.

! WARNING !

When measuring high voltage be sure to use proper connections as shown in Figure 1. Failure to do so will cause serious damage to the calibrator.

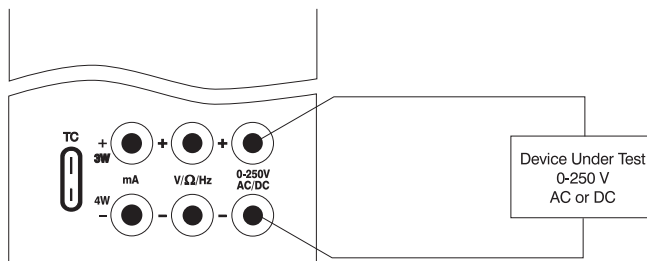

Figure 1.

B. Measuring Low Voltage and Frequency

1. Select the desired mode Voltage or Frequency. Use the "Range" key to select the proper range for the mode chosen.
2. Connect the device under test as shown in Figure 2.

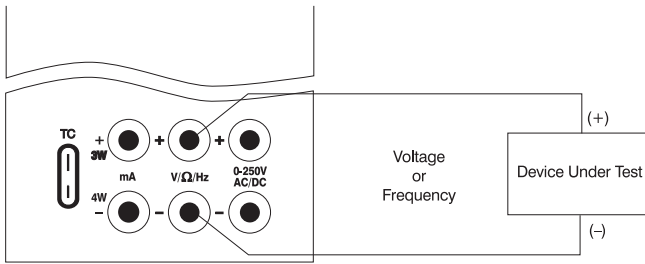

Figure 2.

! WARNING !

Do not exceed 20 VDC at the V/ Ω /Hz input.

C. Measuring Current

1. Select the mA input mode. **Note:** To power the loop while reading current, select the “mAPW” mode.
2. Connect the device under test as shown in Figure 3.
3. Current can either be measured directly in mA or as a percentage such that 4 to 20 mA corresponds to 0 to 100%.

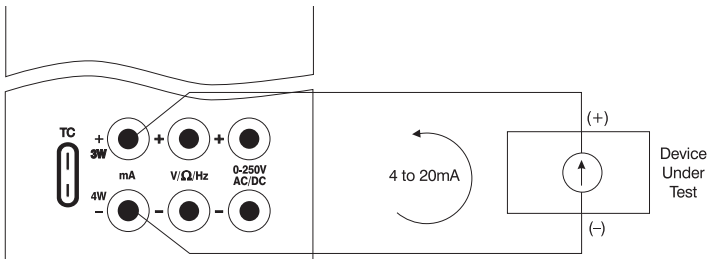

Figure 3.

D. Sourcing Current

1. Select the mA output mode on the calibrator.
2. Connect device under test as shown in Figure 4.
3. Enter the value of desired output current.

Note: If the loop is open “OL” will appear in the display.

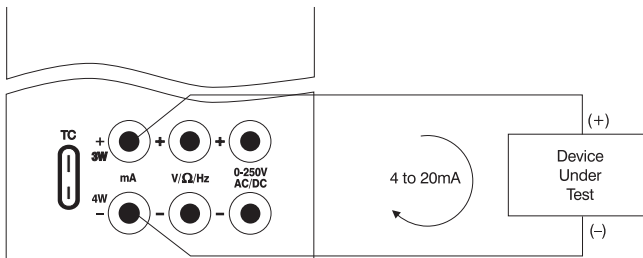

Figure 4.

E. Simulating Current

The PCL1000 can act as a two-wire transmitter and control a 4-20mA loop from the external power supply for that loop.

1. Select the mA “2W” output mode.
2. Connect the device as shown in figure 5.
3. Enter the desired output.

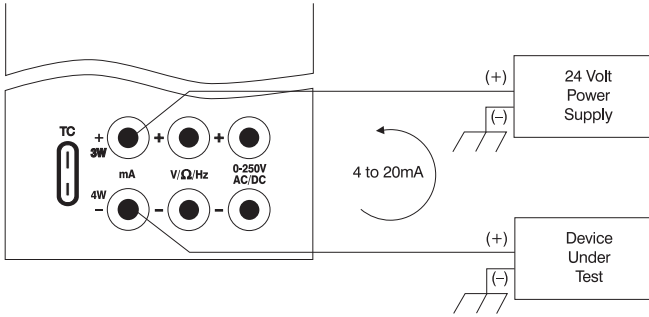

Figure 5.

F. Sourcing Voltage/Resistance/Frequency

1. Select the proper operation mode: volts, ohms, frequency.
2. Connect device under test as shown.
3. In the resistance or frequency modes use the “Range” key to choose the desired range for the mode you’re operating in.
4. The PCL1000 is capable of driving up to ± 1 mA on the Voltage and Frequency ranges and is able to handle up to a 3 mA excitation on the Resistance Simulation Range. Exceeding these limits will result in a warning on the display.

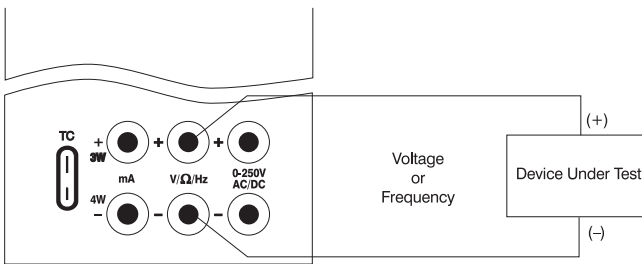

Figure 6.

Note: The frequency output is a 5 Volt square wave with -0.1 volt offset

G. Sourcing a Thermocouple Signal

TC wire must be used to achieve an accurate calibration.

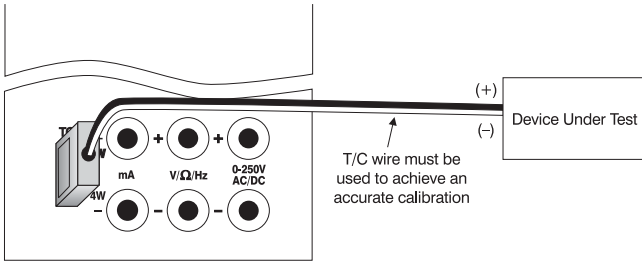

Figure 7.

Note: For best accuracy allow a 10 minute warm-up period after the PCL1000 is turned on.

H. Measuring Temperature Using a Thermocouple

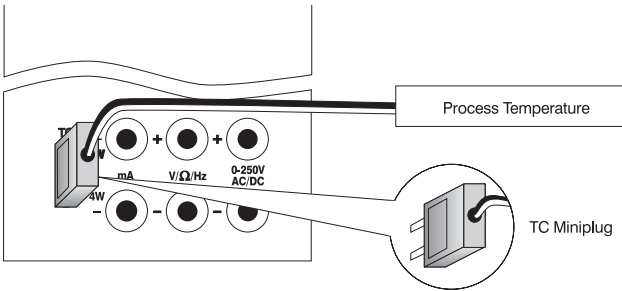
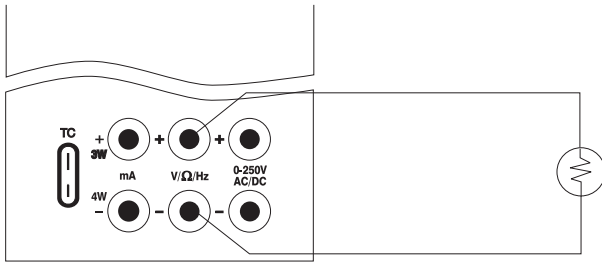

Figure 8.

I. Measuring Resistance (RTDs)

When measuring resistance (ohms) there are 3 choices when using the PCL1000; 2-wire, 3-wire, and 4-wire. While 4-wire offers the highest accuracy, most industrial RTDs are a balance 3-wire. Figure 9. shows how to hook up the PCL1000 for the 3 types of measurements.

1. Choose the desired RTD/ohms range by first pressing the “TC/RTD” key to get into the RTD mode. Then use the “Range” key to select the desired range within the RTD mode.
2. Make sure the PCL1000 is in the Input Mode (Note: that it will indicate 2, 3, or 4W in the upper left corner of the LCD). To set the desired wire configuration use the “Up/Down arrow” keys to toggle through the 2, 3, and 4 wire modes.



Measuring a 2 Wire RTD or Using the Continuity Function

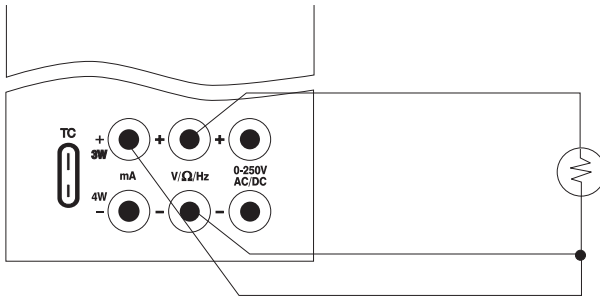

Measuring a 3 Wire RTD

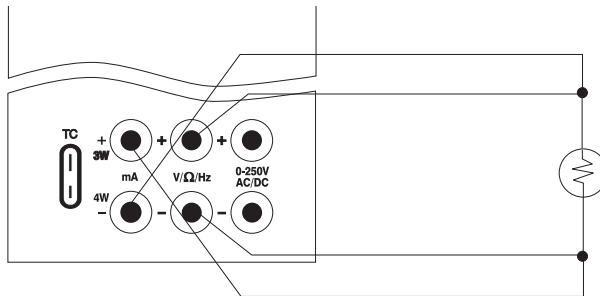

Measuring a 4 Wire RTD

Figure 9.

J. Sourcing Resistance Into a RTD Transmitter

1. As described previously in section F the PCL1000 can source resistance in a RTD Transmitter or measuring device. In many cases the unit under test will require a 3 or 4 wire connection to achieve best accuracy. Refer to Figure 10 for connection information.

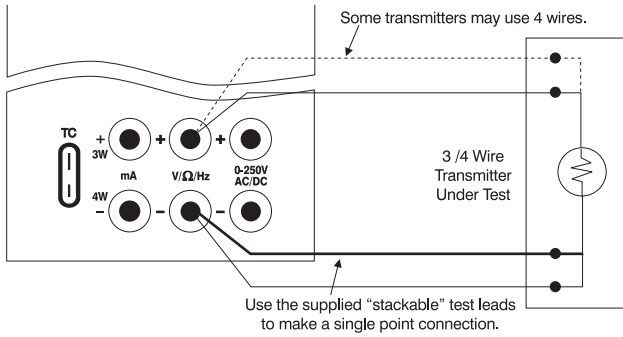

Figure 10.

4. Maintenance

A. Power Requirements

The PCL1000 operates on 4 AA alkaline batteries. To replace the alkaline batteries, remove the two (2) screws on the rear battery door and lift the battery cover.

B. Calibration

The PCL1000 should hold its rated specifications for a minimum of one year. Given this, annual re-calibration is required for best performance.

5. Specifications

Pressure Ranges:	Module Dependent Operates with selected PX971 Transducers	
T/C Ranges:	J, K, T, E, R, S, N, B, L, U including – 10 to 70mV	
RTD Ranges:	Pt 385 (100, 200, 500, 1000 ohms) Pt 392, JIS, Ni120, CU10, YSI400	
Ohms Ranges:	0 to 400.00 and 400.0 to 4000.0	
mA Range:	0 to 24.000 mA	
Voltage:	(Low) Input 0-20.000 V, Output 0-10.000 V (High) Input only 0-250 VDC or VAC	
Frequency:	0-1000.0 CPM 0-1000.0 Hz 0-10.00 KHz	Note: The frequency output is a 5 Volt square wave with –.1 volt offset
Continuity:	0 to 400.0 ohms, audible tone when under 10 ohms	
Accuracy:	T/C Type J: $\pm .3^{\circ}\text{C} \pm 10 \text{ mV}$ ($\pm 0.6^{\circ}\text{C}$ total error) RTD PT100: $\pm .1^{\circ}\text{C} \pm .075 \text{ W}$ ($\pm 0.3^{\circ}\text{C}$ total error) Ohms (400): $\pm 0.1 \text{ W}$ Ohms (3200): $\pm 1.0 \text{ W}$	
mA Compliance:	Up to 1000 W load	
Voltage Drive Capability:	1 mA	
RTD IEX-range:	0.01 mA to 3 mA	
RTD Frequency Response:	10 mS – works with all pulsed XMTR's	
Oper. Temp:	-10°C to 50°C	
Storage Temp:	-40°C to 60°C	
Loop Power:	4 AA alkaline batteries, 25 hours typical operating time	
Size:	7.5" x 4" x 1.5"	

Range & Accuracy

Range	Min	Max	Accuracy (% of reading \pm counts)
V Read (low)	0.000	20.000	0.015% \pm 2
VDC Read (high)	0.0	250.0	0.05% \pm 2
VAC Read (high)	0.0	250.0	0.5% \pm 2
V Source	0.000	10.000	0.015% \pm 2
mV Read	0.00	90.00	0.015% \pm 2
mV Source	0.00	100.00	0.015% \pm 2
mA Read	0.000	24.000	0.015% \pm 2
mA Source	0.000	24.000	0.015% \pm 2
CPM Source	1.0	600.0	\pm 0.05%
Hz Source	1	1000	\pm 0.05%
KHz Source	1.00	10.00	\pm 0.25%
CPM Read	0.0	600.0	0.05% \pm 1
Hz Read	0	1000	0.05% \pm 1
KHz Read	0.00	10.00	0.05% \pm 1

Range & Accuracy (cont.)

Range	Min	Max	Accuracy (% of reading ± counts)
Ohms Read (low)	0.00	400.00	0.1 ohm
Ohms Read (high)	400.0	1500.0	0.5 ohm
	1500.1	3200.0	1.0 ohm

Range	Min	Max	Excitation Current	Accuracy
Ohms Source (low)	5.00	400.00	0.1 to 0.5 mA	0.15 ohm
	5.00	400.00	0.5 to 3 mA	0.1 ohm
Ohms Source (high)	400.0	1500.0	0.05 to 0.8 mA	0.5 ohm
	1500.0	3200.0	0.05 to 0.4 mA	1.0 ohm

Thermocouple Read and Source (All errors included)

Range	Min	Max	Accuracy
J Thermocouple	-200.0	0.0	0.6°C
	0.0	1200.0	0.4°C
K Thermocouple	-200.0	0.0	0.8°C
	0.0	1370.0	0.5°C
T Thermocouple	-200.0	0.0	0.8°C
	0.0	400.0	0.5°C
E Thermocouple	-200.0	0.0	0.5°C
	0.0	950.0	0.4°C
R Thermocouple	-20	0.0	2.49°C
	0	500	1.7°C
	500	1750	1.3°C
S Thermocouple	-20	0	2.4°C
	0	500	1.7°C
	500	1750	1.4°C
B Thermocouple	600	800	2.1°C
	800	1000	1.7°C
	1000	1800	1.3°C
L Thermocouple	-200	0.0	0.45°C
	0.0	900.0	0.4°C
U Thermocouple	-200	0.0	0.7°C
	0.0	400.0	0.45°C
N Thermocouple	-200	0.0	1.1°C
	0.0	1300.0	0.6°C
mV Read/Source	-10.00	75.00	0.015% ± .02 mV

RTD Read and Source

Range	Min	Max	Accuracy
Ni120 (672)	-80.0	260.0	0.2°C
Pt100 (385)	-200.0	800.0	0.33°C
Pt100(3926)	-200.0	630.0	0.3°C
Pt100(3916)	-200.0	630.0	0.3°C
Pt200(385)	-200.0	630.0	0.8°C
Pt500(385)	-200.0	500.0	0.3°C
	500.0	630.0	0.4°C
Pt1000(385)	-200.0	100.0	0.2°C
	100.0	630.0	0.3°C
Cu10	-100.0	250.0	2.2°C
YSI400	15.00	50.00	0.05°C

WARRANTY/DISCLAIMER

OMEGA ENGINEERING, INC. warrants this unit to be free of defects in materials and workmanship for a period of **13 months** from date of purchase. OMEGA's WARRANTY adds an additional one (1) month grace period to the normal **one (1) year product warranty** to cover handling and shipping time. This ensures that OMEGA's customers receive maximum coverage on each product.

If the unit malfunctions, it must be returned to the factory for evaluation. OMEGA's Customer Service Department will issue an Authorized Return (AR) number immediately upon phone or written request. Upon examination by OMEGA, if the unit is found to be defective, it will be repaired or replaced at no charge. OMEGA's WARRANTY does not apply to defects resulting from any action of the purchaser, including but not limited to mishandling, improper interfacing, operation outside of design limits, improper repair, or unauthorized modification. This WARRANTY is VOID if the unit shows evidence of having been tampered with or shows evidence of having been damaged as a result of excessive corrosion; or current, heat, moisture or vibration; improper specification; misapplication; misuse or other operating conditions outside of OMEGA's control. Components in which wear is not warranted, include but are not limited to contact points, fuses, and triacs.

OMEGA is pleased to offer suggestions on the use of its various products. However, OMEGA neither assumes responsibility for any omissions or errors nor assumes liability for any damages that result from the use of its products in accordance with information provided by OMEGA, either verbal or written. OMEGA warrants only that the parts manufactured by the company will be as specified and free of defects. OMEGA MAKES NO OTHER WARRANTIES OR REPRESENTATIONS OF ANY KIND WHATSOEVER, EXPRESSED OR IMPLIED, EXCEPT THAT OF TITLE, AND ALL IMPLIED WARRANTIES INCLUDING ANY WARRANTY OF MERCHANTABILITY AND FITNESS FOR A PARTICULAR PURPOSE ARE HEREBY DISCLAIMED. LIMITATION OF LIABILITY: The remedies of purchaser set forth herein are exclusive, and the total liability of OMEGA with respect to this order, whether based on contract, warranty, negligence, indemnification, strict liability or otherwise, shall not exceed the purchase price of the component upon which liability is based. In no event shall OMEGA be liable for consequential, incidental or special damages.

CONDITIONS: Equipment sold by OMEGA is not intended to be used, nor shall it be used: (1) as a "Basic Component" under 10 CFR 21 (NRC), used in or with any nuclear installation or activity; or (2) in medical applications or used on humans. Should any Product(s) be used in or with any nuclear installation or activity, medical application, used on humans, or misused in any way, OMEGA assumes no responsibility as set forth in our basic WARRANTY/DISCLAIMER language, and, additionally, purchaser will indemnify OMEGA and hold OMEGA harmless from any liability or damage whatsoever arising out of the use of the Product(s) in such a manner.

RETURN REQUESTS/INQUIRIES

Direct all warranty and repair requests/inquiries to the OMEGA Customer Service Department. BEFORE RETURNING ANY PRODUCT(S) TO OMEGA, PURCHASER MUST OBTAIN AN AUTHORIZED RETURN (AR) NUMBER FROM OMEGA'S CUSTOMER SERVICE DEPARTMENT (IN ORDER TO AVOID PROCESSING DELAYS). The assigned AR number should then be marked on the outside of the return package and on any correspondence.

The purchaser is responsible for shipping charges, freight, insurance and proper packaging to prevent breakage in transit.

FOR **WARRANTY** RETURNS, please have the following information available BEFORE contacting OMEGA:

1. Purchase Order number under which the product was PURCHASED,
2. Model and serial number of the product under warranty, and
3. Repair instructions and/or specific problems relative to the product.

FOR **NON-WARRANTY** REPAIRS, consult OMEGA for current repair charges. Have the following information available BEFORE contacting OMEGA:

1. Purchase Order number to cover the COST of the repair,
2. Model and serial number of the product, and
3. Repair instructions and/or specific problems relative to the product.

OMEGA's policy is to make running changes, not model changes, whenever an improvement is possible. This affords our customers the latest in technology and engineering.

OMEGA is a registered trademark of OMEGA ENGINEERING, INC.

© Copyright 2017 OMEGA ENGINEERING, INC. All rights reserved. This document may not be copied, photocopied, reproduced, translated, or reduced to any electronic medium or machine-readable form, in whole or in part, without the prior written consent of OMEGA ENGINEERING, INC.

Where Do I Find Everything I Need for Process Measurement and Control? **OMEGA...Of Course!** *Shop online at omega.comSM*

TEMPERATURE

- ☑ Thermocouple, RTD & Thermistor Probes, Connectors, Panels & Assemblies
- ☑ Wire: Thermocouple, RTD & Thermistor
- ☑ Calibrators & Ice Point References
- ☑ Recorders, Controllers & Process Monitors
- ☑ Infrared Pyrometers

PRESSURE, STRAIN AND FORCE

- ☑ Transducers & Strain Gages
- ☑ Load Cells & Pressure Gages
- ☑ Displacement Transducers
- ☑ Instrumentation & Accessories

FLOW/LEVEL

- ☑ Rotameters, Gas Mass Flowmeters & Flow Computers
- ☑ Air Velocity Indicators
- ☑ Turbine/Paddlewheel Systems
- ☑ Totalizers & Batch Controllers

pH/CONDUCTIVITY

- ☑ pH Electrodes, Testers & Accessories
- ☑ Benchtop/Laboratory Meters
- ☑ Controllers, Calibrators, Simulators & Pumps
- ☑ Industrial pH & Conductivity Equipment

DATA ACQUISITION

- ☑ Communications-Based Acquisition Systems
- ☑ Data Logging Systems
- ☑ Wireless Sensors, Transmitters, & Receivers
- ☑ Signal Conditioners
- ☑ Data Acquisition Software

HEATERS

- ☑ Heating Cable
- ☑ Cartridge & Strip Heaters
- ☑ Immersion & Band Heaters
- ☑ Flexible Heaters
- ☑ Laboratory Heaters

ENVIRONMENTAL MONITORING AND CONTROL

- ☑ Metering & Control Instrumentation
- ☑ Refractometers
- ☑ Pumps & Tubing
- ☑ Air, Soil & Water Monitors
- ☑ Industrial Water & Wastewater Treatment
- ☑ pH, Conductivity & Dissolved Oxygen Instruments