

® PHP-400 SERIES

® Chemical Metering Pumps

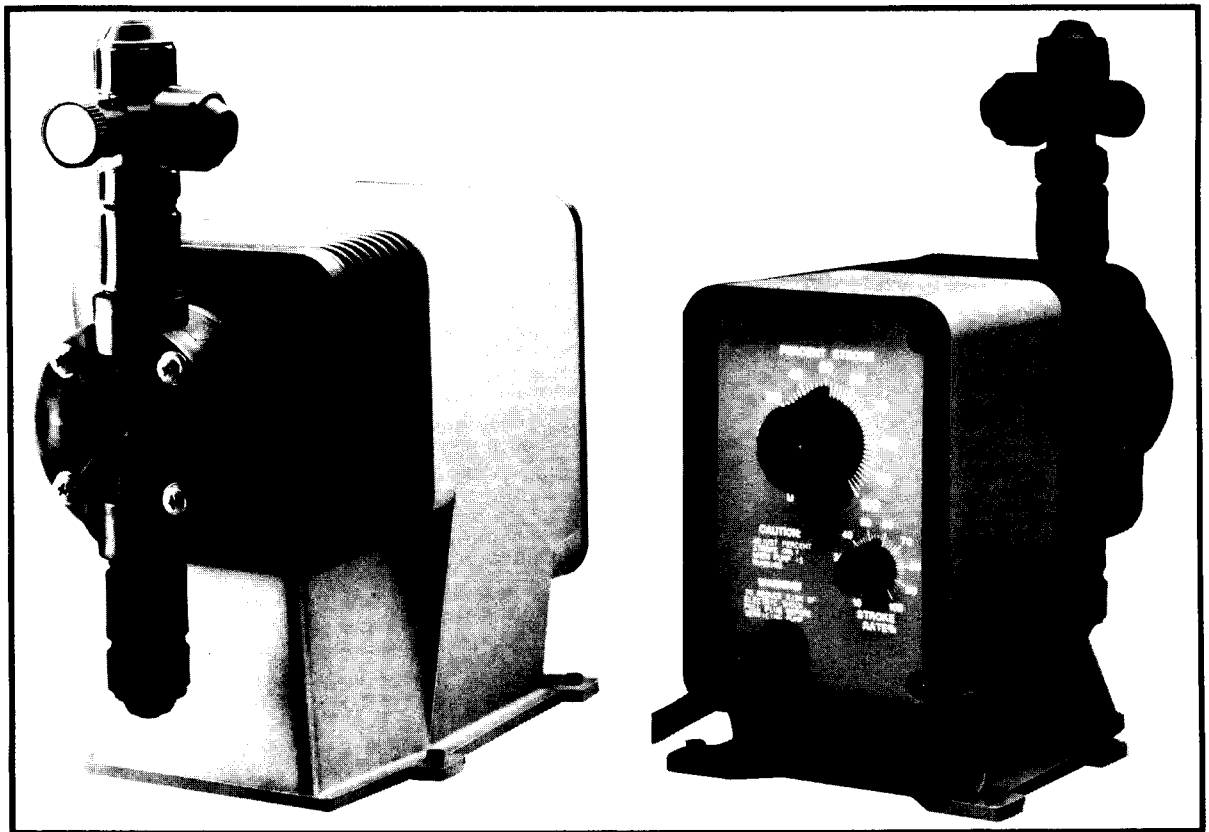

READ ALL CAUTIONS CAREFULLY
BEFORE INSTALLING PUMP



Operator's Manual
M1757/1093

**Servicing USA and Canada: Call OMEGA Toll Free
OMEGA Engineering, Inc.**

One Omega Drive, Box 4047
Stamford, CT 06907-0047 U.S.A.
Headquarters: (203) 359-1660

Sales: 1-800-826-6342 / 1-800-TC-OMEGA

Customer Service: 1-800-622-2378 / 1-800-622-BEST

Engineering: 1-800-872-9436 / 1-800-USA-WHEN

FAX: (203) 359-7700 TELEX: 996404 EASYLINK: 62968934 CABLE OMEGA

**Servicing Europe: United Kingdom Sales and Distribution Center
OMEGA Technologies Ltd.**

25 Swannington Road, Broughton Astley, Leicestershire
LE9 6TU, England

Telephone: 44 (0455) 285520 FAX: 44 (0455) 283912

**The OMEGA Complete Measurement and
Control Handbooks & Encyclopedias™**

- ✓ Temperature
- ✓ Pressure, Strain & Force
- ✓ Flow and Level
- ✓ pH and Conductivity
- ✓ Data Acquisition Systems
- ✓ Electric Heaters



Call for Your FREE Handbook Request Form Today: (203) 359-RUSH

TABLE OF CONTENTS

	<u>Page</u>
SAFETY INSTRUCTIONS	3
INTRODUCTION	4
UNPACKING THE PUMP	5
PRECAUTIONS FOR OPERATION	5
INSTALLATION, PIPING AND WIRING	7
START-UP AND OPERATION	11
MAINTENANCE	13
TROUBLESHOOTING	15
SPECIFICATIONS	16
EXPLODED VIEW DRAWING	17

SAFETY INSTRUCTIONS



When using chemical feed pumps, basic safety precautions should always be followed to reduce risk of fire, electric shock, and personal injury. Failure to follow these instructions could result in death or serious injury.



READ ALL INSTRUCTIONS

GENERAL SAFETY CONSIDERATIONS

- Always wear protective clothing including gloves and safety glasses when working on or near chemical metering pumps.
- Inspect tubing regularly when replenishing chemical solution for cracking or deterioration and replace as necessary. **Always wear protective clothing and safety glasses when inspecting tubing.**
- When pump is exposed to direct sunlight use U.V. resistant tubing.
- Follow directions and warnings provided with the chemicals from the chemical manufacturer. Customer is responsible for determining chemical compatibility with chemical feed pump.
- Secure chemicals and metering pumps making them inaccessible to children and pets.
- Make sure voltage on chemical metering pump matches the voltage at the installation.
- Do not cut plug off electrical cord or the ground lug - consult a licensed electrician for proper installation.
- Pump is **NOT** to be used to handle flammable liquids.

SAFETY OPERATING PROCEDURES

- All pumps are tested with water before shipment. Remove head and dry thoroughly if you are pumping chemical that will react with water (i.e. sulfuric acid). Valve seats, ball checks, gaskets and diaphragm should also be dried.
- Finger tighten connections on pump head. **DO NOT USE WRENCH.** Teflon tape is only necessary when pump is equipped with NPT connections.
- Before repair or moving pump, disconnect power cord or turn off power to pump. De-pressurize system and drain chemical. **(Always wear protective clothing and safety glasses when working on metering pump.)**
- Always consult licensed plumber and electrician before installation and make sure to conform to local codes.
- Consult with local health officials and qualified water conditioning specialist when treating potable water.
- Be sure to de-pressurize system prior to hook-up or disconnection of metering pump.
- If point of injection is lower than chemical tank and pump, install an anti-siphon valve.
- **DO NOT MODIFY** pump, poses potentially dangerous situation and voids warranty.

• For accurate volume output, pump must be **calibrated** under **all** operating conditons.

INTRODUCTION

These installation, operation and maintenance instructions cover your electronic metering pump. Refer to the pump nameplate to determine the actual model.

■ PRINCIPLE OF OPERATION

Diaphragm metering pumps are used to dispense chemicals or fluids. This is achieved by an electromagnetic drive mechanism (solenoid) which is connected to a diaphragm. When the solenoid is pulsed by the control circuit, it displaces the diaphragm which, through the use of check valves, moves the fluid out the discharge under pressure. When the solenoid is deenergized it returns the diaphragm and pulls more fluid into the pump head and the cycle repeats.

The pump stroke rate is controlled by the internal circuit and is changed by turning the rate knob. The mechanical stroke length of the pump is controlled by the stroke length knob.

■ MATERIALS OF CONSTRUCTION

The wetted materials (those parts that contact the solution being pumped) available for construction are polypropylene, 316 Stainless Steel, and PVDF. These materials are very resistant to most chemicals. However, there are some chemicals, such as strong acids or organic solvents, which cause deterioration of some elastomer and plastic parts, such as diaphragm, valve seat, or head. Consult Chemical Resistance Guide or OMEGA for information on chemical compatibility.

Various manufacturers of plastics, elastomers and pumping equipment publish guidelines that aid in the selection of wetted materials for pumping commercially available chemicals. Two factors must always be considered when using an elastomer or plastic part to pump chemicals. They are:

1. **The temperature of service:** Higher temperatures increase the effect of chemicals on wetted materials. The increase varies with the material and the chemical being used. A material quite stable at room temperature might be affected at higher temperatures.
2. **Material choice:** Materials with similar properties may differ greatly from one another in performance when exposed to certain chemicals.

UNPACKING THE PUMP

Remove the Packing List and verify that you have received all equipment. If you have any questions about the shipment, please call the OMEGA Customer Service Department at 1-800-622-2378 or (203) 359-1660. Inspect the container and equipment for any signs of damage. Note any evidence of rough handling in transit. Immediately report any damage to the shipping agent.

NOTE: The carrier will not honor any claims unless all shipping material is saved for their examination. After examining and removing contents, save packing material and carton in the event reshipment is necessary.

The carton should contain: (See Figure A)

- Metering Pump
- * - Clear Flexible Suction Tubing
- * - Stiff White Discharge Tubing
- Foot Valve/Strainer Assy.
- Back Pressure Injection Valve Assy.
- One Instruction Book that you are now reading
- * - Bleed Valve Assembly (most models)
- * NOT SUPPLIED WITH
AISI-316SS PUMPS.

Make sure that all items have been removed from the shipping carton before it is discarded.

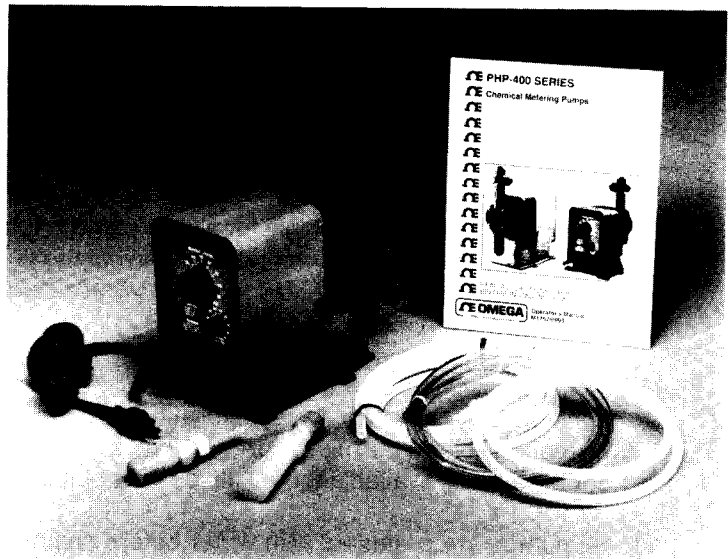

Figure A

PRECAUTIONS FOR OPERATION

Each Electronic Metering Pump has been tested to meet prescribed specifications and safety standards. Proper care in handling, installation and operation will help in ensuring a trouble free installation .

Please read all these cautionary notes prior to installation and start-up of your metering pump.

1. **Important: Pump must be installed and used with supplied back pressure/injection valve. Failure to do so could result in excessive pump output flow.**
2. Handle the pump with care. Dropping or heavy impact may cause not only external damage to the pump, but also to electrical parts inside.
3. Install the pump in a place where the ambient temperature does not exceed 40°C (104°F) and relative humidity below 90%. The pump is water resistant and dust proof by construction and can be used outdoors, however **do not operate the pump submerged**. To avoid high internal pump temperatures, do not operate in direct sunlight.
4. Install the pump in a place convenient for its future maintenance and inspection, then fix it to prevent vibration. Rubber pads are provided for table top operation.
5. Protective caps must be removed prior to installing tubing onto valve assemblies. Use tubing of specified size. Connect the tubing to the suction side securely to prevent the entrance of outside air. Make sure that there is no liquid leakage on the discharge side.

6. Be careful to check that the voltage of the installation matches the voltage indicated on the pump nameplate. Each pump is equipped with a three-prong plug. Always be sure the pump is grounded. To disconnect, do not pull wire but grip the plug with fingers and pull out. Do not use the receptacle in common with heavy electrical equipment which generates surge voltage. It can cause the failure of the electronic circuit inside the pump.
7. Tampering with electrical devices can be potentially hazardous. Always place chemicals and pump installation well out of the reach of children.
8. **Never repair or move the metering pump while operating. Always disconnect electrical power. For safety, always wear protective clothing (protective gloves and safety glasses) when working on or near chemical metering pumps.**
9. An air bleed valve is available for all models with tubing connection. Air purges should be performed when the pump chamber contains no fluid at the time of start-up. As a safety measure, connect the return tubing to the air bleed valve and bypass fluid back to storage tank or a suitable drain.
10. Chemicals used may be dangerous and should be used carefully and according to warnings on the label. Follow the directions given with each type of chemical. Do not assume chemicals are the same because they look alike. Always store chemicals in a safe location away from children. OMEGA cannot be responsible for the misuse of chemicals being fed by the pump. Always have the material safety data sheet (MSDS) available for any fluid being pumped.
11. All pumps are pretested with water before shipment. Remove head and dry thoroughly if you are pumping a material that will react with water, (i.e. sulfuric acid). Valve seats, ball checks, gaskets, and diaphragm should also be dried. Before placing pump into service, extreme care should be taken to follow this procedure.
12. Valve cartridges are stamped to indicate fluid flow direction. Always install so that markings read from top to bottom.
13. When metering hazardous material DO NOT use plastic tubing. Strictly use proper rigid pipe. Consult OMEGA for special adaptors or valve assemblies.
14. **Pump is NOT to be used to handle or meter flammable liquids or materials.**
15. Standard white discharge tubing is not recommended for installations exposed to direct sunlight. Consult OMEGA for special black tubing.
16. Factory will not be held responsible for improper installation of pump, or plumbing. All cautions are to be read thoroughly prior to hook-up and plumbing. For all installations a professional plumber should be consulted. Always adhere to local plumbing codes and requirements.
17. When using pump with pressurized systems, make sure the pressure of the system does not exceed the maximum pressure rating on the pump nameplate. Be sure to de-pressurize system prior to hook-up or disconnecting the metering pump.
18. Electronic power modules are equipped with automatic reset thermal overload devices and may reset unexpectedly.

INSTALLATION, PIPING AND WIRING

The metering pump should be located in an area that allows convenient connections to both the chemical storage tank and the point of injection. The pump is water resistant and dust proof by construction and can be used outdoors, however **do not operate submerged**. Avoid continuous temperatures in excess of 40°C (104°F). To do otherwise will result in damage to the pump.

MOUNTING

Typical mounting arrangements are shown in Figures B to E.

Important: Injection point must be higher than the top of the solution supply tank to prohibit gravity feeding, unless suitable backpressure is always present at the injection point.

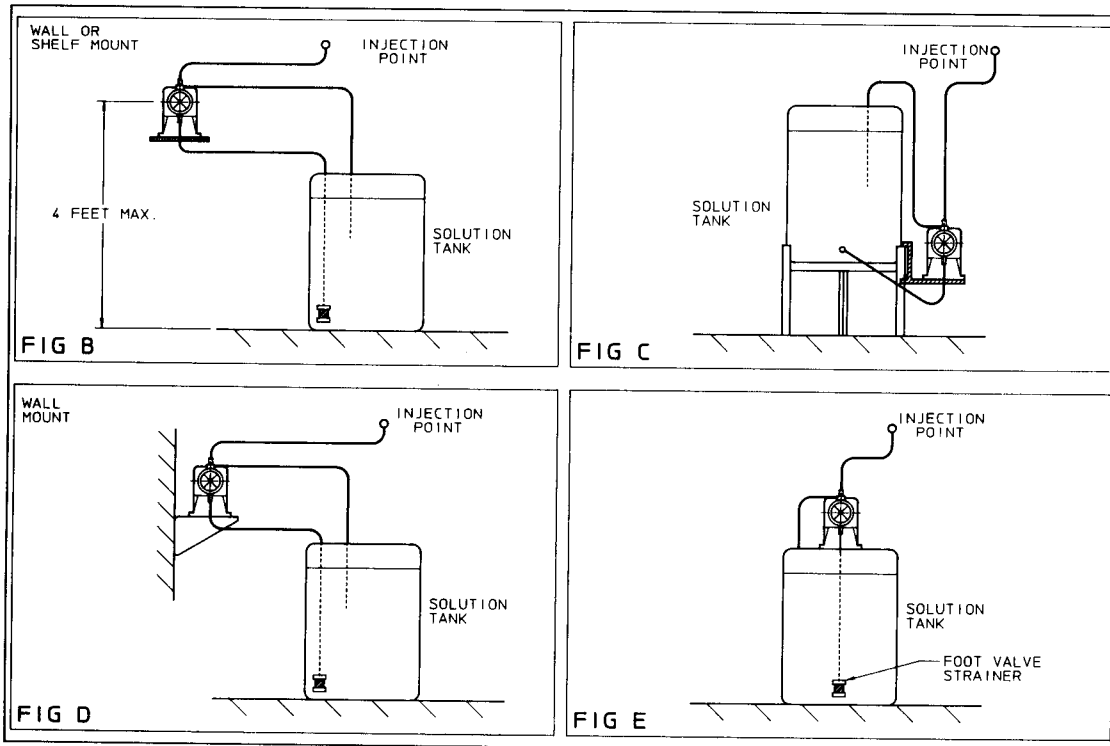

1. For wall or shelf mounting, refer to Figure B. Connect suction tubing to suction valve of chemical pump. Suction valve is the lower valve. Tubing should be long enough so that the footvalve/strainer assembly hangs about 2-3 inches above the bottom of chemical tank. To keep chemical from being contaminated, the tank should have a cover.

2. Flooded suction mounting (installing the pump at the base of the chemical storage tank, Figure C) is the most trouble free type of installation and is recommended for very low output requirements. Since the suction tubing is filled with chemical, priming is accomplished quickly and the chance of losing prime is reduced.

To mount pump, drill 4 holes of 1/4" diameter in the shelf as shown in the dimension drawing (Figure F). Attach pump securely using four #10 bolts and nuts.

3. The pump can be mounted to a wall as shown in Figure D. A wall mount bracket kit is available which includes all necessary hardware to mount the pump to the bracket and the bracket to the wall. Mounting the pump other than as shown in Figure D defeats the purpose of the housing drain. Mounting dimensions for the pump are provided in Figure F for reference.

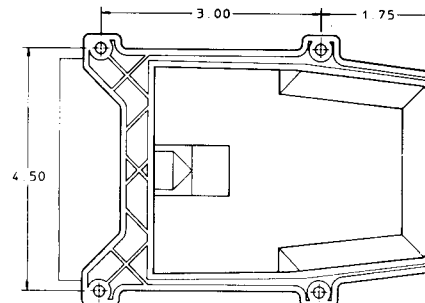

Figure F

- The pump can be mounted on top of a solution tank as shown in Figure E. Install chemical pump on the cover. Insert suction tubing through the center hole and cut tubing so footvalve/strainer hangs about 2-3 inches above the bottom of the tank. Mount the chemical pump rigidly by drilling four 1/4" holes and using four #10 screws and nuts.
- USE AN ANTI-SIPHON VALVE IN THE DISCHARGE LINE whenever the fluid pressure in the discharge line is below atmospheric pressure. This can occur if the injection point is on the suction side of a water pump or against a "negative" head such as when feeding down into a well, SEE FIGURE G1.

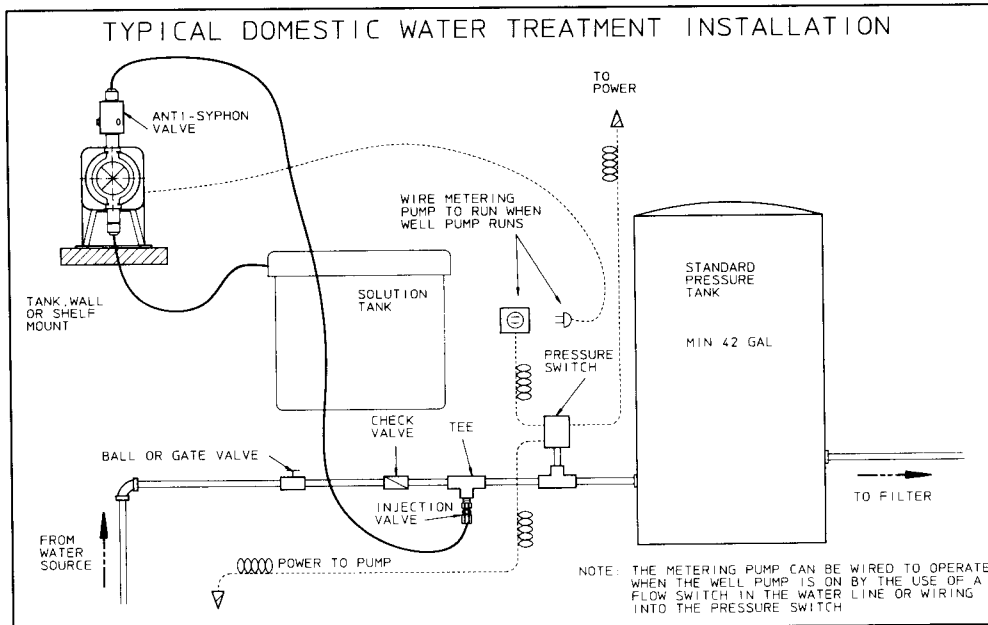
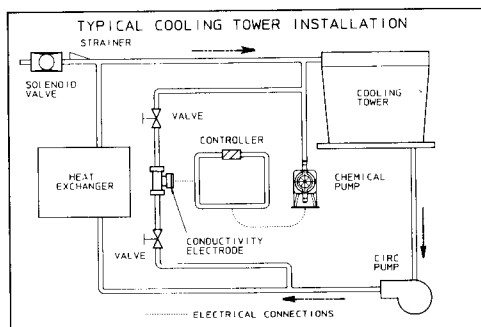

FIG G1



FIGG2

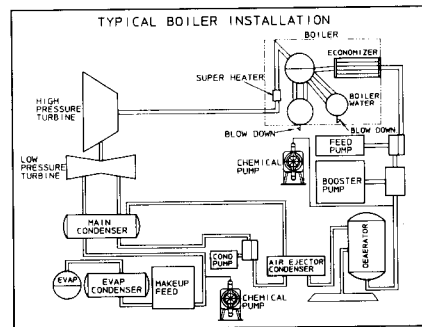
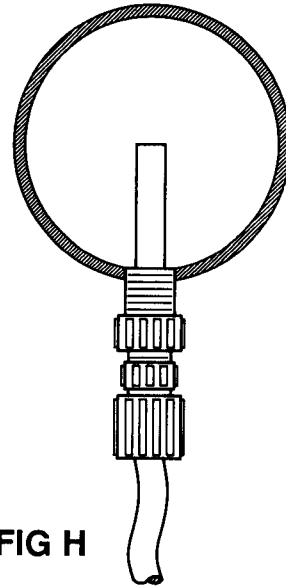

FIG G3

PIPING

- Use provided tubing of specified size for connection. Connect tubing securely to prevent leakage of chemical and the entrance of air. Since plastic nuts are used for fittings, they should not be tightened excessively i.e. hand tighten only.
- If the air bleed valve assembly is being used, a return line (tubing) should be securely connected and routed back to the storage tank. **To avoid possible injury from chemicals do not attempt to prime using a bleed valve without installing a return line.**
- When pump is shelf mounted or top mounted on tank, suction tubing should be kept as short as possible.
- To maintain metering performance, a back pressure/injection valve is provided. The injection valve must be installed in the discharge line. Best practice is to install the injection valve at the point of chemical injection.

5. If the discharge tubing is going to be exposed to direct sunlight, black tubing should be used instead of the standard white translucent tubing supplied with each pump. To obtain, contact OMEGA.
6. To prevent clogging or check valve malfunction always install a strainer assembly to the end of the suction tubing (Figure E). This footvalve/strainer assembly should always be installed 2 to 3 inches above the bottom of the chemical tank. This will help prevent clogging the strainer with any solids that may settle on the tank bottom. The chemical tank and footvalve/strainer should be cleaned regularly, to ensure continuous trouble free operation. If the chemical being pumped regularly precipitates out of solution or does not dissolve easily or completely (e.g. calcium hydroxide), a mixer should be used in the chemical tank. These are readily available in many motor configurations and mountings. To obtain, contact OMEGA.
7. A flooded suction (tank liquid level always at a higher elevation than the pump) is recommended when pumping sodium hypochlorite (NaOCl) and hydrazine solution (N₂H₂) etc. which are liable to produce air bubbles. Maintaining a low liquid temperature will also help eliminate this problem .
8. Pipe corrosion can result if dilution at the injection point does not occur rapidly. This problem is easily prevented by observing this simple rule: install injection fitting so that the end is in the center of the flow stream of the line being treated. Trim injector tip as required. See Figure H. Note: Extended injection assemblies are available for large water lines. Consult OMEGA for more information.



WIRING

1. The metering pump should be wired to an electrical source which conforms to those on the pump nameplate. (Applying higher voltage than the pump is rated for will damage the internal circuit.)
2. **⚠ WARNING** – Risk of electrical shock. This pump is supplied with a three prong grounding type power plug. To reduce risk of electric shock, connect only to a properly grounded, grounding type receptacle.
3. In the electronic circuit of the control unit, measures for surge voltage are made by means of surge absorbing elements and high voltage semiconductors. Nevertheless, excessive surge voltage may cause failure in some areas. Therefore, the receptacle should not be used in common with heavy electrical equipment which generates high voltage. If this is unavoidable, however, measures should be taken by (a) the installation of a surge absorbing element (varister of min. surge resistance 2000A) to the power supply connection of the pump, or (b) the installation of a noise suppression transformer.

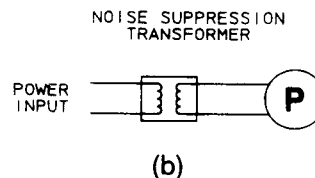
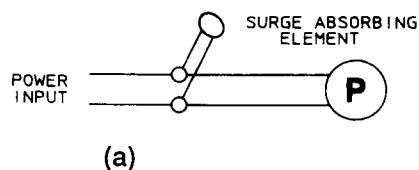

WELL PUMP SYSTEM INSTALLATION

1. Ensure that the metering pump voltage matches the voltage of the well pump. Typical well pump electrical circuits are shown in Figure I. All electric wiring should be installed in accordance to local electrical codes by a licensed electrician.
2. Install the back pressure/injection valve on the discharge side of the metering pump into a tee which is installed into the water line going to the pressure tank. A typical installation is shown in Figure G.

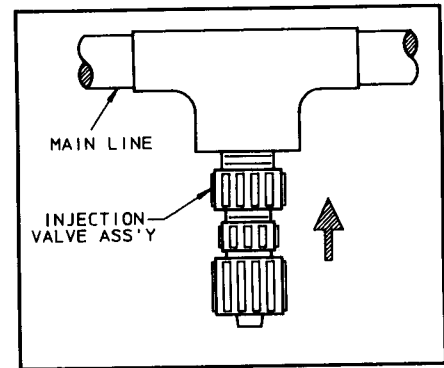

FIG J

Pumps carrying the NSF seal are listed for swimming pools, spas, and hot tubs, and when proper materials are selected, are capable of handling but not limited to the following chemical solutions:

12½% sodium hypochlorite	12% aluminum sulphate
2% calcium hypochlorite	10% hydrochloric acid
20% dichloro-s-triazinone	10% sodium hydroxide
5% trichloro-s-triazinone	5% sodium carbonate

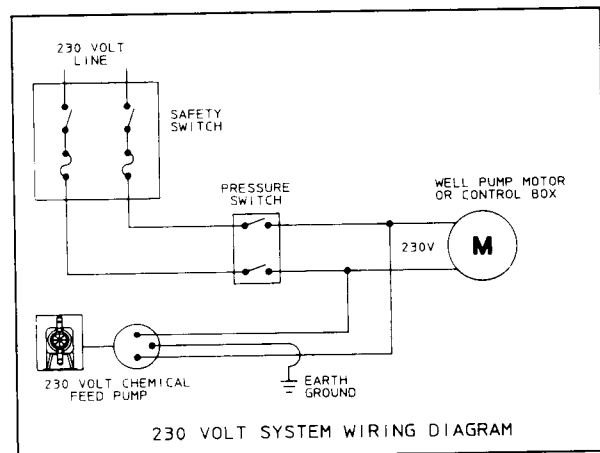
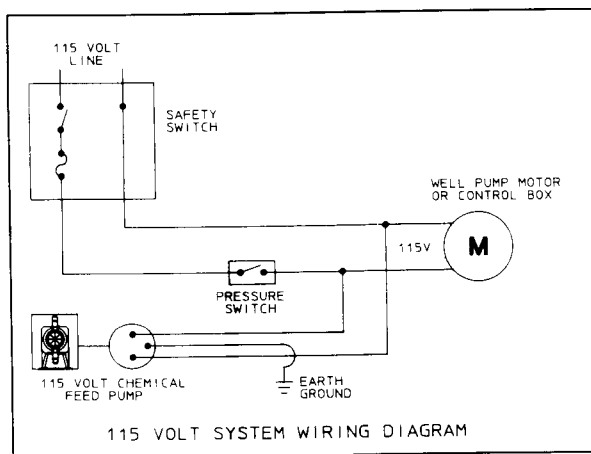

FIG I

START UP AND OPERATION

POWER

All metering pumps are available in 115 volts at 50/60 Hertz, single phase. Optionally 230 volts at 50/60 Hertz, single phase can be provided. **Prior to start-up always check to insure that the pump voltage/frequency/phase matches that of the power supply.**

PRIMING

CAUTION : When working on or around a chemical metering pump installation, protective clothing and gloves and safety glasses should be worn at all times.

All pumps are tested with water. If the chemical to be pumped reacts when mixed with water (e.g. sulfuric acid) the pumphead should be removed and dried thoroughly along with the diaphragm and valve seats.

1. Plug the pump into an appropriate outlet.
2. Adjust the stroke rate knob to the 100% setting mark (for more information see "Capacity Control") .
3. Adjust the stroke length knob to the 100% setting mark (for more information see "Capacity Control").
4. If the discharge line is connected directly to a pressurized system it should be temporarily bypassed during priming of the pump. A bleed valve will simplify this operation by allowing easy bypass of the discharge fluid. All air must be purged from the pumphead before the pump will pump against pressure.

Air Bleed Operation:

- A) While pump is running, turn adjustment screw counterclockwise.
- B) Run with valve open until a solid stream of fluid comes out of the bypass tubing (1/4 x 3/8 supplied with valve), no air bubbles.
- C) Close air bleed valve by turning adjustment screw clockwise.

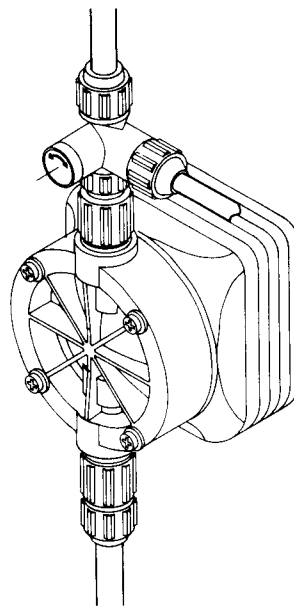

5. Chemical should reach the pumphead after a few minutes of operation. If not, remove the discharge fitting and moisten the discharge valve area (ball check and valve seats) with a few drops of chemical being fed to the metering pump. **For safety, always use protective clothing and gloves, wear safety glasses and use a proper container to hold the chemical.**
6. If the pump continues to refuse to prime, refer to Troubleshooting Section of these instructions.
7. Once the pump has been primed and is pumping the chemical through the head, turn off the power, reconnect the discharge tubing (if it had been removed) and immediately clean any spilled chemical that is on the pump housing or head.
8. Turn the power on once more and adjust the pump flow to the desired rate (see "Capacity Control").
9. Always check the calibration of the pump after start-up. It's best to calibrate the pump under your typical use conditions.

CAPACITY CONTROL

Capacity can be controlled by means of the stroke length adjusting knob or stroke frequency adjusting knob. Graphs are for illustration purposes only. Use a calibration column for accurate calibration. Contact OMEGA for proper calibration equipment.

(1) Stroke Frequency Adjustment:

- Stroke frequency can be controlled from 10 to 100% (12 to 125 spm) by means of the electronic circuit.
- Stroke frequency can be set by means of the stroke frequency adjusting knob even while the pump is in operation.

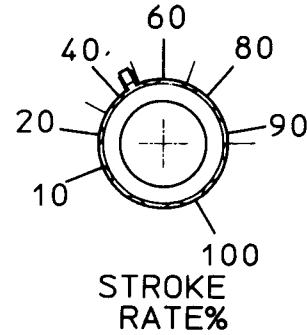

(2) Stroke Length Adjustment:

- Stroke length can be controlled within 0 to 100% of the diaphragm displacement. (It should be controlled within 10 to 100% for practical use.)
- Stroke length can be set by means of the stroke length adjusting knob while the pump is in operation. **Do not turn the knob while the pump is stopped.**

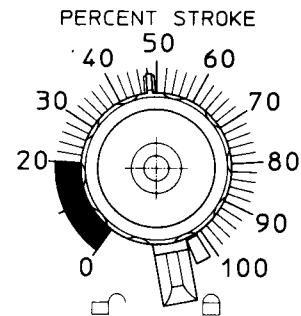

(3) Controlling Procedure:

Proper set points for stroke length and stroke frequency should be determined after consideration of the pump and characteristics of the fluid. The following procedure is recommended from the viewpoint of pump performance. **Note: The closer the stroke length is to 100% the better the pump performance will be.**

- A) Set the stroke length to 100% then adjust the stroke frequency for coarse capacity control.
- B) Measure the capacity.
- C) When the measured capacity is less than the required value, increase the stroke frequency and measure the capacity again.
- D) Then, adjust the stroke length for fine capacity control.
- E) Finally, measure the capacity and make sure that the required value is obtained.

Example	Selected Model	=	PHP-404
	Set Stroke Length	=	100%
	Set Stroke Rate	=	100%
	Output Capacity (Rated Pressure)	=	30 GPD*
	Desired Flow	=	12 GPD
	Adjust Stroke Rate to 80%		
	Output Capacity	=	$0.80 \times 30 = 24 \text{ GPD}^*$
	Stroke Length Setting	=	$\frac{12}{24} \times 100 = 50\% \text{ approx.}$

Thus to obtain the desired flow, stroke length is set at 50% and stroke rate is set at 80%, i.e. output capacity = $0.80 \times 0.50 \times 30 = 12 \text{ GPD}^*$

* Check these values by measurement. Output capacity is higher when feeding against less than rated pressure.

MAINTENANCE

⚠ CAUTION : Before performing any maintenance or repairs on chemical metering pumps, be sure to disconnect all electrical connections and insure that all pressure valves are shut off and pressure in the pump and lines has been bled off.

Always wear protective clothing, gloves and safety glasses when performing any maintenance or repairs on chemical metering pumps.

ROUTINE MAINTENANCE

1. Routinely check the physical operating condition of the pump. Look for the presence of any abnormal noise, excessive vibration, low flow and pressure output or high temperatures [when running constantly at maximum stroke rate, the pump housing temperature can be up to 160°F (70°C)].
2. For optimum performance, cartridge valve assemblies should be changed every 4-6 months. Depending on the application, more frequent changes may be required. Actual operating experience is the best guide in this situation. Repeated short-term deterioration of valve seats and balls usually indicates a need to review the suitability of wetted materials selected for the application. Contact OMEGA for guidance.
3. Check for leaks around fittings or as a result of deteriorating tubing, e.g. when standard white translucent discharge tubing is exposed to direct sunlight. Take appropriate action to correct leak by tightening fittings or replacing components.
4. Keep the pump free of dirt/debris as this provides insulation and can lead to excessive pump temperatures.
5. If the pump has been out of service for a month or longer, clean the pumphead/valve assemblies by pumping fresh water for approximately 30 minutes. If the pump does not operate normally after this "purging run", replace cartridge valve assemblies.

DISASSEMBLY AND ASSEMBLY DIAPHRAGM REMOVAL

1. Flush pumphead and valve assemblies out by running pump on water or other suitable neutralizing solution. Wash outside of pump down if chemical has dripped on pump.
2. Set stroke length of pump to 0% and unplug pump.
3. Disconnect tubing or piping from the pump. Remove the four pumphead screws and then remove the pumphead assembly.
4. Remove the diaphragm by grasping it at the outer edges and turning it counterclockwise until it unscrews from the electronic power module (EPM). Don't lose the deflection plate or diaphragm shims which are behind the diaphragm. Note shim quantity can be from 0 to 2.
5. Inspect diaphragm if it is intended to be used again. Look for indications of the Teflon face being overstretched, (localized white areas) or the elastomer on the back of the diaphragm being worn. Excessive amounts of either condition require diaphragm replacement.

DIAPHRAGM REPLACEMENT

Refer to drawings in the back of the manual.

1. When replacing the diaphragm, it's always a good idea to replace the valve cartridges and other worn parts.
2. Set pump stroke length to 0% and unplug the pump.
3. If you kept the shims from the original diaphragm or know the original quantity you can avoid Step #4 for shimming the diaphragm and go to Step #5.
4. Slide the diaphragm deflection plate onto the back of the diaphragm stud, radius side towards the diaphragm. Next slide two shims onto the diaphragm threaded stud and screw the diaphragm into the EPM unit. Refer to sketch. Turn diaphragm clockwise until it stops turning. If there is a gap between the adaptor and diaphragm, repeat the procedure removing one shim each time until the diaphragm just touches the adaptor or is slightly recessed.
5. Apply grease to areas of the diaphragm that contact the deflection plate or radius on the adaptor.
6. Screw the diaphragm into the EPM unit's shaft with the deflection plate and appropriate number of shims in between.
7. Adjust stroke length to 50%. It is easier to do this if you temporarily turn the pump on. Place the pumphead onto the adaptor with flow arrows pointing up and install and tighten pumphead screws. Tighten screws until pumphead pulls up against adaptor.
8. Adjust stroke length back to 100% for easier priming and place pump back into service.

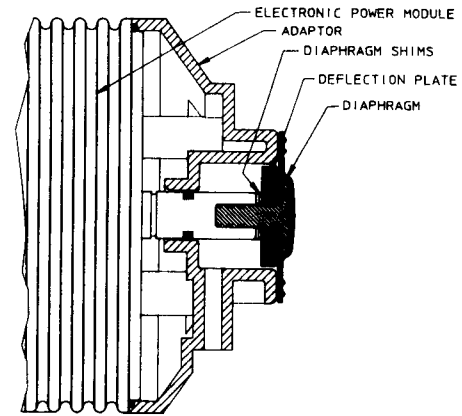

VALVE REPLACEMENT

1. Flush pump to clean any chemical from pumphead.
2. Unplug pump and disconnect any tubing or piping.
3. Unscrew valve cartridges and discard. Also remove O-Rings down inside pumphead.
4. Using new O-Rings, install new valve cartridges with stamped letters reading from top to bottom. Hand tighten only, do not use wrenches or pliers.
5. Reconnect tubing or piping and reinstall the pump.

TROUBLESHOOTING

PROBLEM	PROBABLE CAUSE	REMEDY
LOSS OF CHEMICAL RESIDUAL	<ol style="list-style-type: none"> 1. Pump setting too low 2. Scale at injection point 3. Solution container allowed to run dry 	<ol style="list-style-type: none"> 1. Adjust to higher setting (pump must be operating during the stroke length adjustment). 2. Clean injection parts with 8% muriatic acid or undiluted vinegar. (Also, see Maintenance Section). 3. Refill the tank with solution and prime. (See Start-Up and Operation Section).
TOO MUCH CHEMICAL	<ol style="list-style-type: none"> 1. Pump setting too high 2. Chemical in solution tank too rich 3. Siphoning of chemical into well or main line 	<ol style="list-style-type: none"> 1. Lower pump setting (pump must be operating to adjust stroke length knob). 2. Dilute chemical solution. NOTE: For chemical that reacts with water, it may be necessary to purchase a more dilute grade of chemical from chemical supplier. 3. Test for suction or vacuum at the injection point. If suction exists, install an anti-siphon valve.
LEAKAGE AT TUBING CONN.	<ol style="list-style-type: none"> 1. Worn tube ends 2. Chemical attack 	<ol style="list-style-type: none"> 1. Cut off end of tubing (about 1") and then replace as before. 2. Consult OMEGA for alternate material.
FAILURE TO PUMP	<ol style="list-style-type: none"> 1. Leak in suction side of pump 2. Valve seats not sealing 3. Low setting on pump 4. Low solution level 5. Diaphragm ruptured 6. Pump head cracked or broken 7. Pump head contains air or chlorine gas 8. Breakdown or disconnection of wiring 9. Voltage drop 10. Malfunction of electronic control board 	<ol style="list-style-type: none"> 1. Examine suction tubing. If worn at the end, cut approximately an inch off and replace. 2. Clean valve seats if dirty or replace with alternate material if deterioration is noted. 3. When pumping against pressure, the dials should be set above 20% capacity for a reliable feed rate. 4. Solution must be above foot valve. 5. Replace diaphragm as shown in the "Maintenance Section." Check for pressure above rated maximum at the injection point. NOTE: Chemical incompatibility with diaphragm material can cause diaphragm rupture and leakage around the pump head. 6. Replace pump head as shown in "Maintenance Section." Make sure fittings are hand tight only. Using pliers and wrench can crack pump head. Also, chemical incompatibility can cause cracking and subsequent leakage. 7. After turning off all pressure lines, disconnect discharge tubing and install bleed valve assembly. 8. Connect wiring properly. Check fuse or circuit breaker. 9. Take corrective measures after investigation of cause. 10. Contact OMEGA.

PROBLEM	PROBABLE CAUSE	REMEDY
PUMP LOSES PRIME	<ol style="list-style-type: none"> 1. Dirty check valve 2. Ball checks not seating or not sealing properly 3. Solution container allowed to run dry 	<ol style="list-style-type: none"> 1. Remove and replace or clean off any scale or sediment. 2. Check seat and ball checks for chips, clean gently. If deformity or deterioration is noted, replace part with proper material. Resulting crystals can hold check valves open, therefore the valves must be disassembled and cleaned. Be sure to replace all parts as shown in the Parts Diagram (at the end of the manual). 3. Refill container with proper chemical.
FITTING LEAKAGE	<ol style="list-style-type: none"> 1. Loose fittings 2. Broken or twisted gasket 3. Chemical attack 	<ol style="list-style-type: none"> 1. All fittings can be hand tightened to prevent leakage. Clean off chemicals which have spilled on pump. 2. Check gaskets and replace if broken or damaged. 3. Consult OMEGA for alternate material.
PUMP WILL NOT PRIME	<ol style="list-style-type: none"> 1. Too much pressure at discharge 2. Check valves not sealing 3. Output dials not set at maximum 4. Suction lift height too much 5. Pump equipped with spring loaded high viscosity valves 	<ol style="list-style-type: none"> 1. Turn off all pressure valves, loosen outlet tubing connection at discharge point. Remove discharge valve cartridge. Dampen ball check and valve seats with a few drops of solution. Set pump dials to maximum rate. When pump is primed, reconnect all tubing connections. 2. Disassemble, loosen, clean and check for deterioration or swelling. Reassemble and wet the valve assembly, then prime. See Start-Up and Operating Section. 3. Always prime pump with output dials set at maximum rated capacity. 4. Decrease suction lift or pull vacuum on pump discharge until pump is primed. 5. Loosen discharge valve to aid in priming, take necessary safety precautions, or apply vacuum to pump discharge.

PHP-400 SERIES SPECIFICATIONS

POWER:	115 Vac, 60 Hz
LIQUID END:	Glass-filled polypropylene on "G" models, PVDF on "K" models, and 316 SS on "S" models
VALVE BALLS:	Ceramic for "G" and "K" models; Teflon for "S" models
SEALS:	Hypalon for "G" and "K" models; Teflon for "S" models
DIAPHRAGM:	Teflon-faced Hypalon
METERING RANGE:	10 to 100% of capacity
MAXIMUM FREQUENCY:	125 strokes/minute
NOMINAL POWER:	50 Watts
PEAK POWER CONSUMPTION:	130 Watts
DIMENSIONS:	10" H x 5" W x 9.5" D (250 x 127 x 241 mm)
WEIGHT:	10 lbs. (4.5 kg)

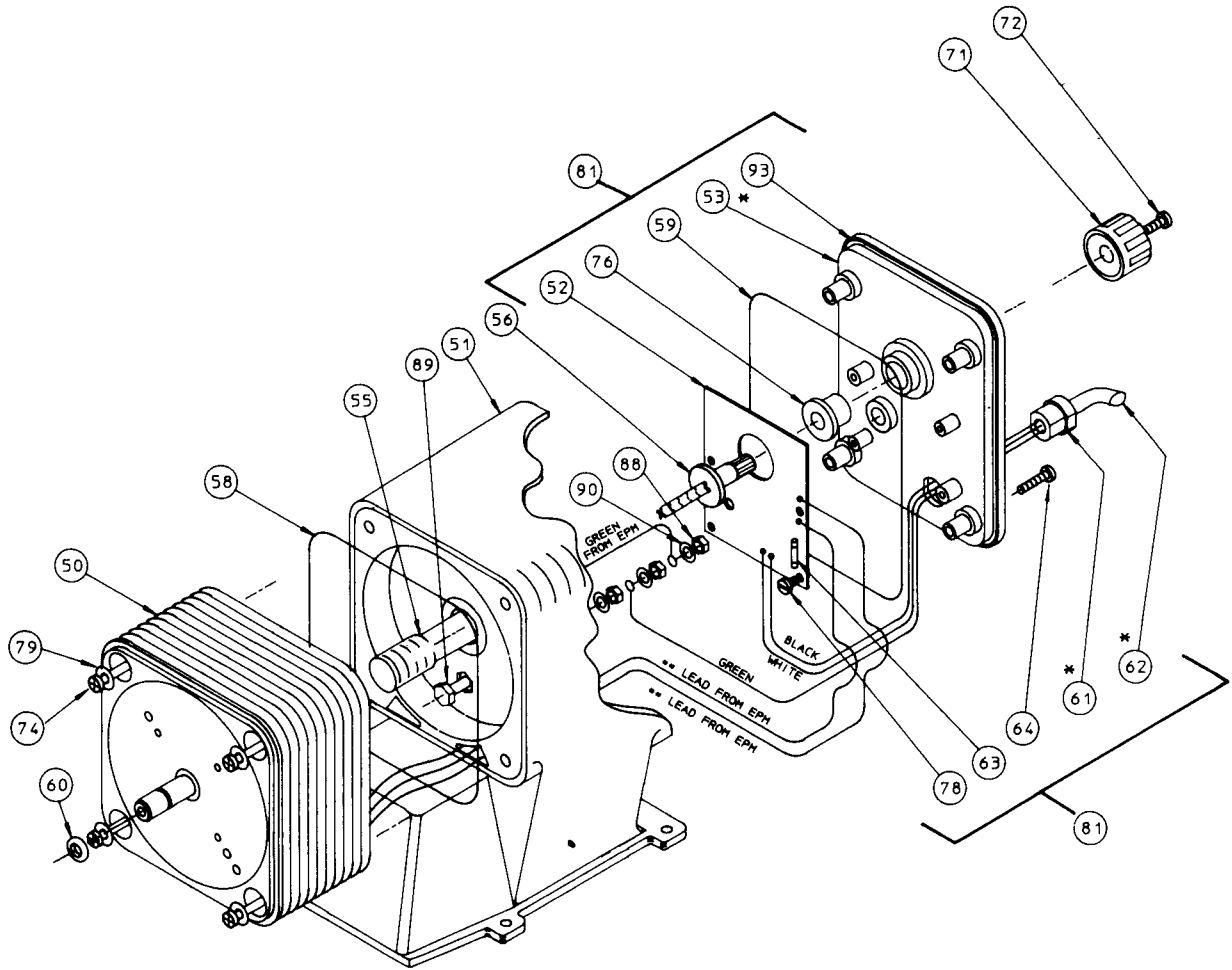

ITEM	PART NAME	QTY	ITEM	PART NAME	QTY
50	ELECTRONIC POWER MODULE (EPM)	1	72	KNOB MOUNTING SCREW	1
51	HOUSING	1	74	EPM MOUNTING SCREW	4
52	ELECTRONIC CONTROL BOARD	1			
53*	CONTROL PANEL	1	76	GROMMET, STROKE LENGTH	1
55	FEMALE ADJUSTMENT SHAFT	1	77*	PANEL LABEL (NOT SHOWN)	1
56	MALE ADJUSTMENT SHAFT	1	78	ELECTRONIC CONTROL BOARD SCREW	2
58	EPM/HOUSING O-RING	1	79	EPM MOUNTING WASHER	4
59	CONTROL PANEL O-RING	1	81	CONTROL PANEL ASSEMBLY	1
60	SECONDARY SEAL	1	88	GROUND LUG NUT	3
61*	STRAIN RELIEF	1	89	GROUND LUG BOLT	1
62*	POWER CORD	1	90	GROUND LUG WASHER	3
63	FUSE	1	93	CONTROL PANEL SUB-ASSEMBLY	1
64	CONTROL PANEL SCREW	4			
71	KNOB, STROKE LENGTH	1			

* COMPONENTS OF ITEM 93.
 ** 115 VOLT EPM UNITS HAVE GREY LEADS.
 230 VOLT EPM UNITS HAVE RED LEADS.

ALL DIMENSIONS ARE IN INCHES

**PHP-400 SERIES
 DRIVE ASSEMBLY**

SECTION/PAGE					
EFFECTIVE		02/14/92			
SUPERSEDES		NEW			
REF	REVISION UPDATE	DATE		DWN BY: CMF	AC00140
				DATE: 01/08/92	

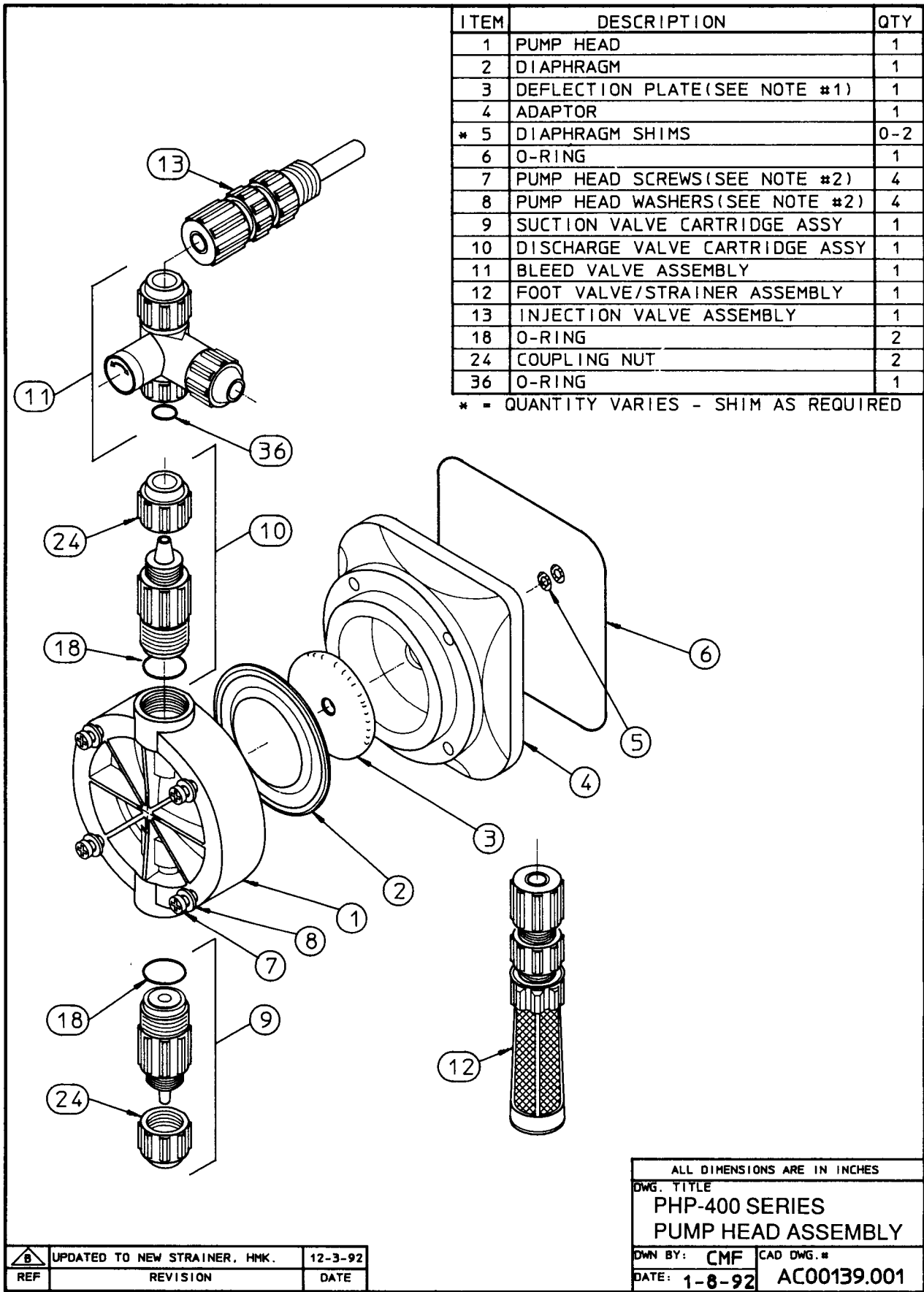

ITEM	DESCRIPTION	QTY
1	PUMP HEAD	1
2	DIAPHRAGM	1
3	DEFLECTION PLATE (SEE NOTE #1)	1
4	ADAPTOR	1
* 5	DIAPHRAGM SHIMS	0-2
6	O-RING	1
7	PUMP HEAD SCREWS (SEE NOTE #2)	4
8	PUMP HEAD WASHERS (SEE NOTE #2)	4
9	SUCTION VALVE CARTRIDGE ASSY	1
10	DISCHARGE VALVE CARTRIDGE ASSY	1
11	BLEED VALVE ASSEMBLY	1
12	FOOT VALVE/STRAINER ASSEMBLY	1
13	INJECTION VALVE ASSEMBLY	1
18	O-RING	2
24	COUPLING NUT	2
36	O-RING	1

* = QUANTITY VARIES - SHIM AS REQUIRED

ALL DIMENSIONS ARE IN INCHES	
DWG. TITLE PHP-400 SERIES PUMP HEAD ASSEMBLY	
DWN BY: CMF	CAD DWG. #
DATE: 1-8-92	AC00139.001

	UPDATED TO NEW STRAINER. HMK.	12-3-92
REF	REVISION	DATE



WARRANTY

OMEGA warrants this unit to be free of defects in materials and workmanship and to give satisfactory service for a period of **13 months** from date of purchase. OMEGA Warranty adds an additional one (1) month grace period to the normal **one (1) year product warranty** to cover handling and shipping time. This ensures that our customers receive maximum coverage on each product. If the unit should malfunction, it must be returned to the factory for evaluation. Our Customer Service Department will issue an Authorized Return (AR) number immediately upon phone or written request. Upon examination by OMEGA, if the unit is found to be defective it will be repaired or replaced at no charge. However, this WARRANTY is VOID if the unit shows evidence of having been tampered with or shows evidence of being damaged as a result of excessive corrosion; or current, heat, moisture or vibration; improper specification; misapplication; misuse or other operating conditions outside of OMEGA's control. Components which wear or which are damaged by misuse are not warranted. These include contact points, fuses, and triacs.

We are glad to offer suggestions on the use of our various products. Nevertheless OMEGA only warrants that the parts manufactured by it will be as specified and free of defects.

OMEGA MAKES NO OTHER WARRANTIES OR REPRESENTATIONS OF ANY KIND WHATSOEVER, EXPRESSED OR IMPLIED, EXCEPT THAT OF TITLE AND ALL IMPLIED WARRANTIES INCLUDING ANY WARRANTY OF MERCHANTABILITY AND FITNESS FOR A PARTICULAR PURPOSE ARE HEREBY DISCLAIMED.

LIMITATION OF LIABILITY: The remedies of buyer set forth herein are exclusive and the total liability of OMEGA with respect to this order, whether based on contract, warranty, negligence, indemnification, strict liability or otherwise, shall not exceed the purchase price of the component upon which liability is based. In no event shall OMEGA be liable for consequential, incidental or special damages.

Every precaution for accuracy has been taken in the preparation of this manual; however, OMEGA ENGINEERING, INC. neither assumes responsibility for any omissions or errors that may appear nor assumes liability for any damages that result from the use of the products in accordance with the information contained in the manual.

RETURN REQUESTS / INQUIRIES

Direct all warranty and repair requests/inquiries to the OMEGA ENGINEERING Customer Service Department. Call toll free in the USA and Canada: 1-800-622-2378, FAX: 203-359-7811; International: 203-359-1660, FAX: 203-359-7807.

BEFORE RETURNING ANY PRODUCT(S) TO OMEGA, YOU MUST OBTAIN AN AUTHORIZED RETURN (AR) NUMBER FROM OUR CUSTOMER SERVICE DEPARTMENT (IN ORDER TO AVOID PROCESSING DELAYS). The assigned AR number should then be marked on the outside of the return package and on any correspondence.

FOR **WARRANTY** RETURNS, please have the following information available BEFORE contacting OMEGA:

1. P.O. number under which the product was PURCHASED,
2. Model and serial number of the product under warranty, and
3. Repair instructions and/or specific problems you are having with the product.

FOR **NON-WARRANTY** REPAIRS OR **CALIBRATION**, consult OMEGA for current repair/calibration charges. Have the following information available BEFORE contacting OMEGA:

1. Your P.O. number to cover the COST of the repair/calibration,
2. Model and serial number of product, and
3. Repair instructions and/or specific problems you are having with the product.

OMEGA's policy is to make running changes, not model changes, whenever an improvement is possible. That way our customers get the latest in technology and engineering.

OMEGA is a registered trademark of OMEGA ENGINEERING, INC.

© 1993 OMEGA ENGINEERING, INC. All rights reserved including illustrations. Nothing in this manual may be reproduced in any manner, either wholly or in part for any purpose whatsoever without written permission from OMEGA ENGINEERING, INC.

OMEGA® ... Your Source for Process Measurement and Control

TEMPERATURE

- Thermocouple, RTD & Thermistor Probes, Connectors, Panels & Assemblies
- Wire: Thermocouple, RTD & Thermistor
- Calibrators & Ice Point References
- Recorders, Controllers & Process Monitors
- Infrared Pyrometers

PRESSURE/STRAIN FORCE

- Transducers & Strain Gauges
- Load Cells & Pressure Gauges
- Displacement Transducers
- Instrumentation & Accessories

FLOW/LEVEL

- Rotameters, Gas Mass Flowmeters & Flow Computers
- Air Velocity Indicators
- Turbine/Paddlewheel Systems
- Totalizers & Batch Controllers

pH/CONDUCTIVITY

- pH Electrodes, Testers & Accessories
- Benchtop/Laboratory Meters
- Controllers, Calibrators, Simulators & Pumps
- Industrial pH & Conductivity Equipment

DATA ACQUISITION

- Data Acquisition and Engineering Software
- Communications-Based Acquisition Systems
- Plug-in Cards for Apple, IBM & Compatibles
- Datalogging Systems
- Recorders, Printers & Plotters

HEATERS

- Heating Cable
- Cartridge & Strip Heaters
- Immersion & Band Heaters
- Flexible Heaters
- Laboratory Heaters