

**MADE
IN
USA**



User's Guide



<http://www.omega.com>
e-mail: info@omega.com

HHP-SG Handheld Strain Gage Indicator Operator's Manual

omega.com[®]

ΩOMEGA

OMEGAnet™ On-Line Service
<http://www.omega.com>**Internet e-mail**
info@omega.com**Servicing North America:**

USA: One Omega Drive, Box 4047
ISO 9001 Certified Stamford, CT 06907-0047
Tel: (203) 359-1660 FAX: (203) 359-7700
e-mail: info@omega.com

Canada: 976 Bergar
Laval (Quebec) H7L 5A1
Tel: (514) 856-6928 FAX: (514) 856-6886
e-mail: canada@omega.com

For immediate technical or application assistance:

USA and Canada: Sales Service: 1-800-826-6342 / 1-800-TC-OMEGA®
Customer Service: 1-800-622-2378 / 1-800-622-BEST®
Engineering Service: 1-800-872-9436 / 1-800-USA-WHEN®
TELEX: 996404 EASYLINK: 62968934 CABLE: OMEGA

Mexico and Latin America: Tel: (95) 800-TC-OMEGASM FAX: (95) 203-359-7807
En Español: (203) 359-7803 e-mail: espanol@omega.com

Servicing Europe:

Benelux: Postbus 8034, 1180 LA Amstelveen, The Netherlands
Tel: (31) 20 6418405 FAX: (31) 20 6434643
Toll Free in Benelux: 06 0993344
e-mail: nl@omega.com

Czech Republic: ul. Rude armady 1868, 733 01 Karviná - Hranice
Tel: 420 (69) 6311899 FAX: 420 (69) 6311114
e-mail: czech@omega.com

France: 9, rue Denis Papin, 78190 Trappes
Tel: (33) 130-621-400 FAX: (33) 130-699-120
Toll Free in France: 0800-4-06342
e-mail: france@omega.com

Germany/Austria: Daimlerstrasse 26, D-75392 Deckenpfronn, Germany
Tel: 49 7056 9398-0 (operator) FAX: 49 7056 9398-29
Toll Free in Germany: 0130 11 21 66
e-mail: germany@omega.com

United Kingdom: One Omega Drive,
ISO 9002 Certified River Bend Technology Centre
Manchester, M44 5EX, England
Tel: 44 (161) 777-6611 FAX: 44 (161) 777-6622
Toll Free in England: 0800-488-488
e-mail: info@omega.co.uk

It is the policy of OMEGA to comply with all worldwide safety and EMC/EMI regulations that apply. OMEGA is constantly pursuing certification of its products to the European New Approach Directives. OMEGA will add the CE mark to every appropriate device upon certification.

The information contained in this document is believed to be correct but OMEGA Engineering, Inc. accepts no liability for any errors it contains, and reserves the right to alter specifications without notice.

WARNING: These products are not designed for use in, and should not be used for, patient connected applications.



This device is marked with the international caution symbol. It is important to read the Setup Guide before installing or commissioning this device as it contains important information relating to safety and EMC.

TABLE OF CONTENTS



1.	Getting Started	
1.1	Unpacking	1
1.2	General Description	1
1.3	Features	2
2.	Safety Considerations	3
3.	Installation and Operation	
3.1	Front of the Meter	4
3.2	Rear of the Meter	6
3.3	Factory Settings	7
3.4	Battery Installation or Replacement	7
3.5	Transducer Hookup	8
4.	Calibration, Gain Selection and Adjustments	9
4.1	Switches & Jumper Locations	9
5.	Customized Scaling Procedure	15
6.	Specifications	19



FIGURES AND TABLES

FIGURES

3.1 Front Panel	4
3.2 Rear View	6
4.1 Zero Calibration	9

TABLES

4.1 Gain Resistor Selection for 1.24 Volts Excitation Voltage	10
4.2 Gain Resistor Selection for 2.50 Volts Excitation Voltage	11
4.3 Zero Resistor Selection	12
4.4 S3 Jumper Switch Description	13
4.5 Solder Switch Description	13
5.1 Gain Switch Settings	18

1.1 Unpacking

Remove the packing list and verify that you have received all equipment. If you have any questions, contact the Customer Service Department nearest you.

Upon receipt of shipment, inspect the container and equipment for any signs of damage. Note any evidence of rough handling in transit. Immediately report any damage to the shipping agent.

**Note**

The carrier will not honor any claims unless all shipping material is saved for their examination. After examining and removing contents, save packing material and carton in the event reshipment is necessary.

Please ensure that a 9 Volt battery is included.

1.2 General Description

The hand held calibrator is a digital indicator for strain gage type transducers such as load cells, torque sensors, or millivolt pressure sensors. It provides excitation voltage for the transducer and displays the readings on a liquid crystal display (LCD). The LCD has a 3 1/2 active digits (0-1999 counts) and an additional dummy zero if needed. The calibrator can display either the actual value of the signal (tracking mode) or the peak value (peak mode). It operates on a standard 9 Volt battery and provides an indication of low battery.

1.2 General Description (continued)

It has two internal reference voltages for powering the bridge. The 1.24 Volt reference is used with the 1K Ohm bridge and below whereas the 2.5 Volt with the 2.5K/5K Ohm bridges and above. Failure to properly select the excitation voltage can result in the calibrator drawing excessive current.

(The calibrator provides amplification, common-mode rejection and controls the LCD Display).

The calibrator is designed for 0.5 to 4.0 mV/V bridge sensitivity range. A ZERO POT and SPAN POT is provided for calibration. See Section 4 for more details.

1.3 Features

- Portable, hand held indicator for bridge type transducers
- 9 Volt battery powered
- Scalable display with dummy zero
- Built-in transducer excitation
- Track/peak modes available
- Selectable decimal point
- Low battery indication
- Blanking overrange



This device is marked with the international Caution symbol. It is important to read this manual before installing or commissioning this device as it contains important information relating to Safety and EMC (Electromagnetic Compatibility).

Note

Unpacking & Inspection

Unpack the instrument and inspect for obvious shipping damage. Do not attempt to operate the unit if damage is found.

Note

- Always disconnect power before changing signal and power connections.
- Do not use this instrument on a work bench without its case for safety reasons.
- Do not operate this instrument in flammable or explosive atmospheres.
- Do not expose this instrument to rain or moisture.
- Allow for adequate ventilation to ensure instrument does not exceed operating temperature rating.
- Use electrical wires with adequate size to handle mechanical strain and power requirements. Install without exposing bare wire outside the connector to minimize electrical shock hazards.

EMC Considerations

- Whenever EMC is an issue, always use shielded cables.
- Never run signal and power wires in the same conduit.
- Use signal wire connections with twisted-pair cables.
- Install Ferrite Bead(s) on signal wires close to the instrument if EMC problems persist.

3.1 Front of the Meter

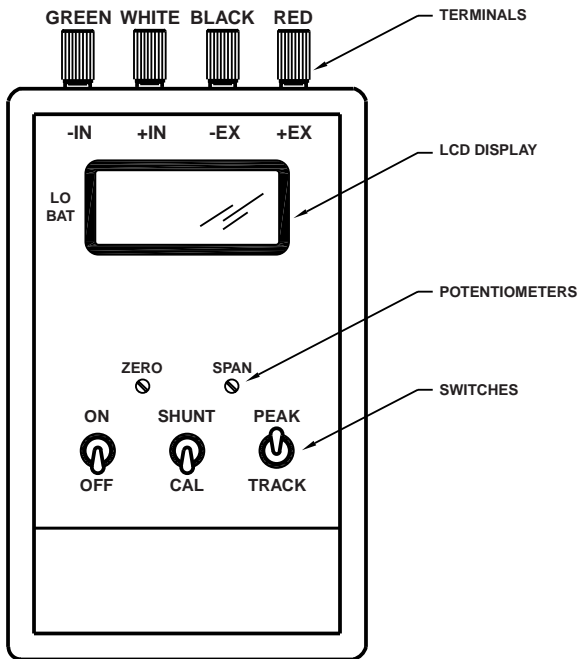

Figure 3.1 — Front Panel

DESCRIPTION

ON/OFF Switch — controls power flow from the battery to all circuits.

SHUNT CAL Switch — places a known resistor (59 K Ohm) across the transducer, so that a known output (half scale, 1000 count approximately) is seen, and is used to self-calibrate the instrument.

Note: a count of 1000 is applicable only to a 350 Ohm bridge.

PEAK/TRACK Switch — selects the mode of operation of the instrument. In the PEAK mode, the instrument will retain the reading of the most positive value detected during the operation. In the TRACK mode, the instrument will continuously follow the variations of the input signal. To reset the peak (when in peak mode), merely switch the instrument to the track mode.

ZERO Potentiometer — is used to obtain a zero indication, thus compensating for drifts and electrical offsets that may exist in the transducer or the instrument.

SPAN Potentiometer - adjusts the fine gain of the amplifier. It is used to assure proper gain-level setting per given transducer.

LCD Display — appears through a window on the front panel. The LO-BATT indication appears at the upper left side of the display and indicates when the 9 Volt battery has dropped below 5.2 Volts.

TERMINALS — Above the front panel are four connectors used to power and read from the transducer. The front-panel label describes the function of each terminal.

3.2 Back of the Meter

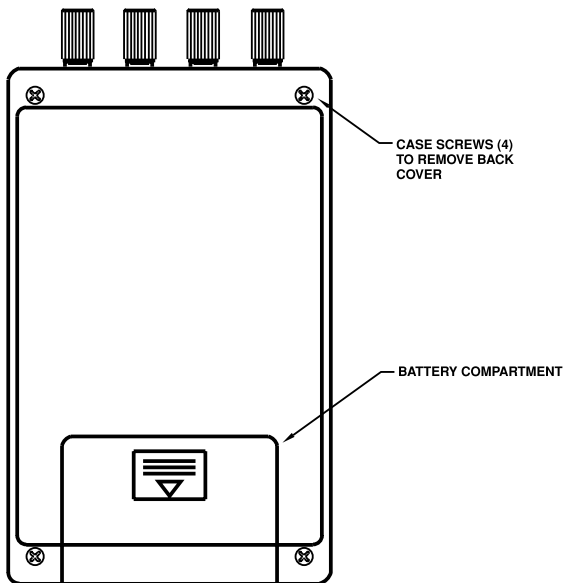

Figure 3.2 – Rear View

3.3 Factory Setting

The calibrator is factory configured to:

- 1XXX.0 decimal point location
- No dummy zero
- 2.5 Volt Transducer excitation
- 3 mV/V sensitivity

If any of the previous characteristics do not suit your application, follow steps in Section 4 of this manual to reconfigure to your needs.

3.4 Battery Installation or Replacement

3.4.1 Turn off the calibrator.

3.4.2 Remove the battery compartment door located on the rear of the unit, sliding the door in the direction of the arrow.

3.4.3 Remove the battery from the compartment and carefully remove it from the battery clip. Do not pull on the wires on either end.

3.4.4 Attach a new battery to the battery clip observing polarity and place the battery back into its recess in the case.

3.4.5 Replace the battery compartment door.

**Note**

If you see (LO-BAT) in the upper left of the LCD, the battery voltage is 5.2 Volts or less. It is time to replace the battery.

3.5 Transducer Hookup

Connect the transducer to the calibrator using the binding post connectors shown in Figure 3.1. Observe proper color coding as shown on the Transducer Information Sheet provided with your transducer. Allow the transducer to warm up for a few minutes, to stabilize the drift.

CALIBRATION, GAIN SELECTION AND ADJUSTMENTS

4.1 ZERO CALIBRATION

Close appropriate switches to obtain desired gain. See Table 4.1 and 4.2 for proper selection. Gain selection is the initial step for ZERO calibration. This also provides course SPAN calibration as well.

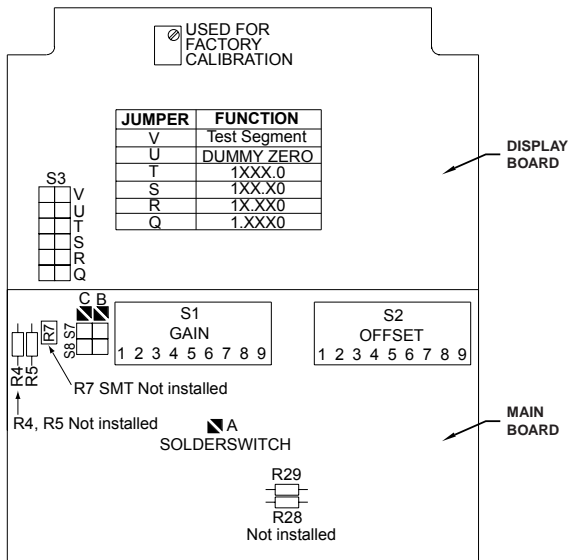

Figure 4.1 – Switches & Jumper Locations

Table 4.1**GAIN RESISTOR SELECTION FOR 1.24 VOLTS EXCITATION VOLTAGE**

SENSITIVITY (mV/V)	S8	S1-7	S1-6	S1-5	S1-4	S1-3	S1-2	S1-1
0.45 to 0.49	C	C	C	C	C	C	C	C
0.50 to 0.54	C	C	C	C	O	C	C	O
0.55 to 0.59	C	C	C	O	O	O	C	O
0.60 to 0.65	C	C	O	C	O	O	O	O
0.66 to 0.72	C	O	C	C	O	C	C	O
0.73 to 0.79	C	O	O	C	O	C	C	C
0.80 to 0.87	C	O	O	C	C	O	O	O
0.88 to 0.96	C	O	O	O	C	O	O	O
0.97 to 1.05	O	C	C	C	C	O	O	C
1.06 to 1.16	O	C	C	O	C	O	C	O
1.17 to 1.27	O	C	O	C	C	O	C	O
1.28 to 1.40	O	C	O	O	O	C	C	C
1.41 to 1.54	O	C	O	O	O	O	C	C
1.55 to 1.70	O	C	O	O	O	O	C	O
1.71 to 1.87	O	O	C	C	O	C	C	C
1.88 to 2.06	O	O	C	C	C	O	O	C
2.07 to 2.27	O	O	O	C	C	C	C	C
2.28 to 2.49	O	O	C	O	C	O	C	O
2.50 to 2.74	O	O	O	C	C	C	O	C
2.75 to 3.02	O	O	C	C	O	O	O	O
3.03 to 3.32	O	O	C	O	O	C	O	O
3.33 to 3.65	O	O	O	O	C	O	C	C
3.66 to 4.02	O	O	O	O	O	C	C	C
4.03 to 4.42	O	O	O	C	O	O	C	O
4.43	O	O	O	O	C	C	O	O

Note

(C=CLOSE / O=OPEN)

FOR 1.24V EXCITATION S1-8 CLOSED.

CALIBRATION & GAIN SELECTION

4

Table 4.2

GAIN RESISTOR SELECTION FOR 2.50 VOLTS EXCITATION VOLTAGE

SENSITIVITY (mV/V)	S8	S1-7	S1-6	S1-5	S1-4	S1-3	S1-2	S1-1
0.45 to 0.49	O	C	C	C	C	C	O	C
0.50 to 0.54	O	C	C	O	C	O	C	C
0.55 to 0.59	O	C	C	O	O	C	C	O
0.60 to 0.65	O	C	C	O	O	C	O	O
0.66 to 0.72	O	C	C	O	O	O	O	O
0.73 to 0.79	O	C	O	O	O	C	O	C
0.80 to 0.87	O	C	O	O	O	C	O	O
0.88 to 0.96	O	O	C	O	C	C	C	C
0.97 to 1.05	O	O	C	C	O	O	C	C
1.06 to 1.16	O	O	C	C	C	O	O	O
1.17 to 1.27	O	O	C	O	C	C	O	O
1.28 to 1.40	O	O	C	O	O	C	O	C
1.41 to 1.54	O	O	C	O	C	O	O	O
1.55 to 1.70	O	O	O	C	O	C	C	O
1.71 to 1.87	O	O	O	O	C	C	O	C
1.88 to 2.06	O	O	O	C	C	O	O	O
2.07 to 2.27	O	O	O	O	C	O	C	O
2.28 to 2.49	O	O	O	O	C	C	O	O
2.50 to 2.74	O	O	O	O	O	O	C	C
2.75 to 3.02	O	O	O	O	O	C	O	C
3.03 to 3.32	O	O	O	C	O	O	O	O
3.33 to 3.65	O	O	O	O	C	O	O	O
3.66 to 4.02	O	O	O	O	O	O	C	O
4.03 to 4.42	O	O	O	O	O	C	O	O
4.43	O	O	O	O	O	O	O	C

(C=CLOSE / O=OPEN)

Note

FOR 2.50V EXCITATION S1-9 IS CLOSED.
See NOTES 1, 2, and 3 at end of section.

- 4.1.1** Apply zero signal.
- 4.1.2** Using Table 4.3, select and Close the appropriate switches. (if any)

Table 4.3**ZERO RESISTOR SELECTION**

SWITCH	FUNCTION		
	ZERO OFFSET VOLTAGE	DISPLAY COUNT (1.24 VOLT EXC.)	DISPLAY COUNT (2.50 VOLT EXC.)
S2-1	-40 mV	-757 (± 3)	-729 (± 3)
S2-2	-20 mV	-373 (± 3)	-358 (± 3)
S2-3	-10 mV	-184 (± 3)	-177 (± 3)
S2-4	-5 mV	-90 (± 3)	-86 (± 3)
S2-5	+5 mV	+92 (± 3)	+87 (± 3)
S2-6	+10 mV	+186 (± 3)	+177 (± 3)
S2-7	+20 mV	+373 (± 3)	+357 (± 3)
S2-8	+40 mV	+756 (± 3)	+726 (± 3)
S2-9	+80 mV	+1543 (± 3)	+1478 (± 3)
S2-None	0 mV	0 (± 3)	0 (± 3)

- 4.1.3** This will provide coarse adjustment.
- 4.1.4** Use ZERO POT to fine tune to a display count of 000.

4.2 SPAN CALIBRATION

- 4.2.1** Adjust ZERO POT to a 000 display count as suggested in section 4.1.
- 4.2.2** Apply full scale signal per given strain gage. For 3mV/V and 1.24 V excitation, apply 3.720 mV at \pm SIGNAL input.
- 4.2.3** Use SPAN POT to fine tune to a 1999 display count.
- 4.3** After proceeding through the steps above, apply a ZERO signal again and check for a 000 display count. If the ZERO has shifted, repeat the steps for ZERO and SPAN calibration.

Table 4.4

S3 JUMPER SWITCH DESCRIPTION

JUMPER SWITCH	FUNCTION SELECTED DECIMAL POINT POSITION
V	TEST SEGMENT
U	DUMMY ZERO
T	1XXX.0
S	1XX.X0
R	1X.XX0
Q	1.XXX0

Table 4.5

SOLDER SWITCH DESCRIPTION

SOLDER SWITCH	FUNCTION
A	Output is connected to SPAN POT. See NOTE 4.
B	Gain Resistor R6 (750 Ohm) is selected. See Table 4.1 and 4.2.
C	Gain Resistor R7 (OPEN) is selected. Default OPEN. See NOTE 5.

- 1** The sensitivities increase in 10% increments. The SPAN POT range is $\pm 10\%$ which should cover the entire sensitivity range from 0.5 to 4.0 mV/V. Two extra through-hole resistor locations R4, R5 and one surface mount resistor, R7 are available for covering any sensitivity value not covered by resistors in the tables above. (See Figure 4.1).

Note

- 2** The required through hole resistor value can be calculated by using the following formulas:

R-gain (Gain setting resistor) = $60,000 / (\text{Gain} - 4)$ where

Gain (Design gain) = $V\text{-out} / (V\text{-sensitivity} \times V\text{-excitation})$

Units are in Volts and Ohms.

- 3** The formulas above will give you the correct output when the SPAN POT is connected to the circuit. With the SPAN POT in the circuit, it will give you twice the desired output. Therefore V-out equal to half the required output should be used. Examples are shown below:

Example: V-out = 100 mV (a V-out of 100mV will give you an actual output of 200mV) (1999 counts on the LCD Display)

V-sensitivity = 3 mV/V

V-excitation = 1.24 Volts

Gain = $100 \text{ mV} / (3 \text{ mV/V} \times 1.24) = 26.9$

R-gain = $60,000 / (26.9 - 4) = 2.62 \text{ K Ohms}$

- 4** For SPAN POT to be connected and the output adjustable, solder switch "A" needs to be Open.
- 5** R4, R5 can be any through-hole resistor value as required.
- R7 can be any surface mount resistor value as required.

5.1 CUSTOM SCALING PROCEDURE

Use this procedure if you desire to scale your Strain Gauge Indicator with other than the standard default scaling of 1999 counts equaling a full-scale reading.

- 1** Determine the full-scale reading you desire in terms of counts. This must be between 0 and 1999 counts.

Example: You desire a full-scale reading of 500 counts to correspond to an actual reading of 50.0 in/lbs.

- 2** Divide the number of counts determined in step 1 by 10 to obtain the number of mV required to achieve the desired counts.

Example: $\frac{500 \text{ counts}}{10} = 50 \text{ mV}$

- 3** Divide the number of mV obtained in step 2 by 2.

Example: $\frac{50 \text{ mV}}{2} = 25 \text{ mV}$

- 4** Determine the full-scale output of your device (load cell, strain gage, etc.) in terms of mV.

Example: You have a torque cell with a full-scale output sensitivity of 2.2249 mV/V. Multiply this value by the excitation voltage you have selected. (e.g. 1.24V or 2.50V)

$$2.2249 \text{ mV/V} \times 1.24\text{V} = 2.7588 \text{ mV}$$

- 5** Divide the result of step 3 by the result of step 4.

Example: $\frac{25 \text{ mV}}{2.7588} = 9.06$

(This value is the amplifier gain that is necessary to give you the full-scale reading you desire.)

CUSTOMIZED SCALING PROCEDURE

- 6** Look up the gain value calculated in step 5 and find the closest gain value in Table 5.1. (If the value of gain required is not contained in Table 5.1, skip to step 14)
- 7** Read across the table to find the gain desired and the gain switch settings necessary to give you that value.

Table 5.1 (partial)

Example:

S1-1	S1-2	S1-3	S1-4	S1-5	S1-6	S1-7	S8	GAIN
C	O	O	O	O	O	O	O	9

- 8** Open up the Indicator case by removing the four screws which hold the rear cover in place. (see Figure 3.2)
- 9** Set the gain resistor switches to the positions indicated in step 7. (open is up, and closed is down)
- 10** Select the decimal point location (if desired) by using the push-on jumpers “Q” through “T” on the display circuit board. Also select the dummy zero (if desired) by installing the push-on jumper “U” on the display circuit board.
- 11** Close the Indicator case by installing the four screws removed in step 8.
- 12** Connect your device to the Indicator terminals.
- 13** Adjust the ZERO and SPAN pots on the Indicator as necessary to obtain the exact reading you desire.

CUSTOMIZED SCALING PROCEDURE

5

ALTERNATE PROCEDURE FOR GAINS OUTSIDE OF TABLE 5.1 RANGE

14 Use this procedure if the gain value calculated in step 5 is not contained within Table 5.1.

15 Insert the result of step 5 into the following formula:

$$\text{Rgain (ohms)} = \frac{60,000}{(\text{step 5 result} - 4)}$$

Example: $\text{Rgain (ohms)} = \frac{60,000}{(9.06 - 4)} = 11,857 \text{ ohms}$

16 Obtain the nearest standard 1% resistor value that is closest to the step 15 result.

Example: $11,857 \text{ ohms} = 11,800 \text{ ohms}$

17 Open up the Indicator case by removing the four screws which hold the rear cover in place. (see Figure 3.2)

18 Solder the resistor obtained in step 16 into the Indicator main circuit board R4 or R5 location. (The main circuit board is the one with the two 9-position DIP switches located on the board.)

19 Open up all other gain resistors by opening up S1-1 through S1-7 switches (open is up, closed is down) and also open up solder switches "B" and "C" and remove push-on jumpers S7 and S8 all on the main circuit board.

20 Select the decimal point location (if desired) by using the push-on jumpers "Q" through "T" on the display circuit board. Also select the dummy zero (if desired) by installing the push-on jumper "U" on the display circuit board.

21 Close the Indicator case by installing the four screws removed in step 17.

22 Connect your device to the Indicator terminals.

23 Adjust the ZERO and SPAN pots on the Indicator as necessary to obtain the exact reading you desire.

CUSTOMIZED SCALING PROCEDURE

Table 5.1 Gain Switch Settings

S1-1	S1-2	S1-3	S1-4	S1-5	S1-6	S1-7	S8	GAIN
C	C	C	C	C	C	C	C	176
C	C	C	O	O	C	C	C	159
C	C	C	O	O	O	C	C	143
C	O	C	C	C	C	O	C	129
O	C	O	C	O	C	O	C	116
C	C	O	C	O	O	O	C	104
O	O	O	O	C	O	O	C	93
O	O	O	O	O	O	O	C	84
O	C	O	C	O	C	C	O	76
O	O	C	C	C	O	C	O	68
O	O	O	O	O	C	C	O	61
O	O	O	O	C	O	C	O	54
C	O	C	C	C	C	O	O	49
O	O	C	C	C	C	O	O	44
C	O	C	C	O	C	O	O	40
O	C	O	C	O	C	O	O	36
C	C	O	O	O	C	O	O	32
O	O	O	C	O	C	O	O	29
C	O	O	O	O	C	O	O	26
C	O	C	C	O	O	O	O	23
O	O	O	C	C	O	O	O	21
O	C	O	C	O	O	O	O	19
O	C	C	O	O	O	O	O	17
C	O	C	O	O	O	O	O	15
O	O	O	O	C	O	O	O	13
O	O	O	C	O	O	O	O	12
O	C	O	O	O	O	O	O	11
O	O	C	O	O	O	O	O	10
C	O	O	O	O	O	O	O	9
O	O	O	O	O	O	O	O	4

(C=CLOSE / O=OPEN)

Accuracy:	$\pm 0.1 \%$
Supply Voltage:	9 Vdc Transistor Battery
Battery Life:	15 hours minimum with 350 ohm bridge transducer
Supply Current:	20 mA Maximum (350 Ohm Bridge)
Display Output:	3 1/2 Digit LCD Display with Dummy Zero, (1999 counts FS)
Digit Height:	0.4"
Bridge Resistance:	350 ohm to 5K ohm
Minimum Transducer Resistance:	350 ohms
Transducer Excitation:	1.24 Vdc or 2.50 Vdc
Input Signal Sensitivity:	0.5 TO 4 mV/V for full-scale indication of 1999 counts
Conversion Rate:	3 Readings per second
Rollover Error:	± 1 Count maximum
Linearity:	± 1 Count maximum
CMRR:	100 dB
Overvoltage Protection:	15 Vdc Maximum
Excitation Output:	5 mA Maximum (not short circuit protected)
Operating Temp. Range:	0°C to 70°C (32°F to 158°F)
Storage Temp. Range:	-15°C to 85°C (5°F to 185°F)
Humidity Level:	85% or less

Features:

- Scalable display with dummy zero
- Selectable decimal point
- Low voltage indication @ 5.2 Volt
- Blanking overrange
- Peak Detector, < 0.03% per minute bleed-off

Case:

Molded ABS Plastic

Dimensions:3.6" X 6.6" X 1.4"
(91.4 X 167.6 X 35.6mm)



WARRANTY/DISCLAIMER

OMEGA ENGINEERING, INC. warrants this unit to be free of defects in materials and workmanship for a period of **13 months** from date of purchase. OMEGA Warranty adds an additional one (1) month grace period to the normal **one (1) year product warranty** to cover handling and shipping time. This ensures that OMEGA's customers receive maximum coverage on each product.

If the unit should malfunction, it must be returned to the factory for evaluation. OMEGA's Customer Service Department will issue an Authorized Return (AR) number immediately upon phone or written request. Upon examination by OMEGA, if the unit is found to be defective it will be repaired or replaced at no charge. OMEGA's WARRANTY does not apply to defects resulting from any action of the purchaser, including but not limited to mishandling, improper interfacing, operation outside of design limits, improper repair, or unauthorized modification. This WARRANTY is VOID if the unit shows evidence of having been tampered with or shows evidence of being damaged as a result of excessive corrosion; or current, heat, moisture or vibration; improper specification; misapplication; misuse or other operating conditions outside of OMEGA's control. Components which wear are not warranted, including but not limited to contact points, fuses, and triacs.

OMEGA is pleased to offer suggestions on the use of its various products. However, OMEGA neither assumes responsibility for any omissions or errors nor assumes liability for any damages that result from the use of its products in accordance with information provided by OMEGA, either verbal or written. OMEGA warrants only that the parts manufactured by it will be as specified and free of defects. OMEGA MAKES NO OTHER WARRANTIES OR REPRESENTATIONS OF ANY KIND WHATSOEVER, EXPRESSED OR IMPLIED, EXCEPT THAT OF TITLE, AND ALL IMPLIED WARRANTIES INCLUDING ANY WARRANTY OF MERCHANTABILITY AND FITNESS FOR A PARTICULAR PURPOSE ARE HEREBY DISCLAIMED. LIMITATION OF LIABILITY: The remedies of purchaser set forth herein are exclusive and the total liability of OMEGA with respect to this order, whether based on contract, warranty, negligence, indemnification, strict liability or otherwise, shall not exceed the purchase price of the component upon which liability is based. In no event shall OMEGA be liable for consequential, incidental or special damages.

CONDITIONS: Equipment sold by OMEGA is not intended to be used, nor shall it be used: (1) as a "Basic Component" under 10 CFR 21 (NRC), used in or with any nuclear installation or activity; or (2) in medical applications or used on humans. Should any Product(s) be used in or with any nuclear installation or activity, medical application, used on humans, or misused in any way, OMEGA assumes no responsibility as set forth in our basic WARRANTY/DISCLAIMER language, and additionally, purchaser will indemnify OMEGA and hold OMEGA harmless from any liability or damage whatsoever arising out of the use of the Product(s) in such a manner.

RETURN REQUESTS / INQUIRIES

Direct all warranty and repair requests/inquiries to the OMEGA Customer Service Department. BEFORE RETURNING ANY PRODUCT(S) TO OMEGA, PURCHASER MUST OBTAIN AN AUTHORIZED RETURN (AR) NUMBER FROM OMEGA'S CUSTOMER SERVICE DEPARTMENT (IN ORDER TO AVOID PROCESSING DELAYS). The assigned AR number should then be marked on the outside of the return package and on any correspondence.

The purchaser is responsible for shipping charges, freight, insurance and proper packaging to prevent breakage in transit.

FOR **WARRANTY** RETURNS, please have the following information available BEFORE contacting OMEGA:

1. P.O. number under which the product was PURCHASED,
2. Model and serial number of the product under warranty, and
3. Repair instructions and/or specific problems relative to the product.

FOR **NON-WARRANTY** REPAIRS, consult OMEGA for current repair charges. Have the following information available BEFORE contacting OMEGA:

1. P.O. number to cover the COST of the repair,
2. Model and serial number of product, and
3. Repair instructions and/or specific problems relative to the product.

OMEGA's policy is to make running changes, not model changes, whenever an improvement is possible. This affords our customers the latest in technology and engineering.

OMEGA is a registered trademark of OMEGA ENGINEERING, INC.

© Copyright 1999 OMEGA ENGINEERING, INC. All rights reserved. This document may not be copied, photocopied, reproduced, translated, or reduced to any electronic medium or machine-readable form, in whole or in part, without prior written consent of OMEGA ENGINEERING, INC.

Where Do I Find Everything I Need for Process Measurement and Control? OMEGA...Of Course!

TEMPERATURE

- ☑ Thermocouple, RTD & Thermistor Probes, Connectors, Panels & Assemblies
- ☑ Wire: Thermocouple, RTD & Thermistor
- ☑ Calibrators & Ice Point References
- ☑ Recorders, Controllers & Process Monitors
- ☑ Infrared Pyrometers

PRESSURE, STRAIN AND FORCE

- ☑ Transducers & Strain Gauges
- ☑ Load Cells & Pressure Gauges
- ☑ Displacement Transducers
- ☑ Instrumentation & Accessories

FLOW/LEVEL

- ☑ Rotameters, Gas Mass Flowmeters & Flow Computers
- ☑ Air Velocity Indicators
- ☑ Turbine/Paddlewheel Systems
- ☑ Totalizers & Batch Controllers

pH/CONDUCTIVITY

- ☑ pH Electrodes, Testers & Accessories
- ☑ Benchtop/Laboratory Meters
- ☑ Controllers, Calibrators, Simulators & Pumps
- ☑ Industrial pH & Conductivity Equipment

DATA ACQUISITION

- ☑ Data Acquisition & Engineering Software
- ☑ Communications-Based Acquisition Systems
- ☑ Plug-in Cards for Apple, IBM & Compatibles
- ☑ Datalogging Systems
- ☑ Recorders, Printers & Plotters

HEATERS

- ☑ Heating Cable
- ☑ Cartridge & Strip Heaters
- ☑ Immersion & Band Heaters
- ☑ Flexible Heaters
- ☑ Laboratory Heaters

ENVIRONMENTAL MONITORING AND CONTROL

- ☑ Metering & Control Instrumentation
- ☑ Refractometers
- ☑ Pumps & Tubing
- ☑ Air, Soil & Water Monitors
- ☑ Industrial Water & Wastewater Treatment
- ☑ pH, Conductivity & Dissolved Oxygen Instruments