

Flow Transmitter Installation & Maintenance Instructions

M-1038/0105

⚠ CAUTION

This product should be installed and serviced by technically qualified personnel trained in maintaining class flow instrumentation and processing equipment.

⚠ CAUTION

Read instructions thoroughly before installing the unit. If you have any questions regarding product installation or maintenance, call Omega Customer Service for more information.

I. INTRODUCTION

The Flow Transmitter combines the rugged proven technology of a direct reading, piston-type, variable-area flow transmitter, coupled with an electronic signal conditioning circuit. Direct flow rate indication, as well as proportional analog output, is provided simultaneously in this design. The product is sealed against industrial contamination by a NEMA 12 and 13 (IP 52/54) rated enclosure and is suitable for either liquid or gas service.

Uses of the Flow Transmitter include: bearing lubrication; case drain verification, gun drill and machine cooling, pump flow outputs, etc.

II. SPECIFICATIONS

Enclosure Rating

- NEMA 12 & 13 (equivalent to IP 52/54)

Temperature Range

- -20° to 240°F (-29° to 116°C)

Pressure (Aluminum / Brass Operating)

- Liquids (1/4" to 1-1/2"): 3500 psi (241 bar) maximum, with a 3:1 safety factor
- Gases (1/4" to 1-1/2"): 1200 psi (82 bar) maximum, with a 10:1 safety factor

Stainless Steel Operating

- Liquids (1/4" to 1/2"): 6000 psi (414 bar) maximum, with a 3:1 safety factor
- Liquids (3/4" to 1-1/2"): 5000 psi (345 bar) maximum, with a 3:1 safety factor

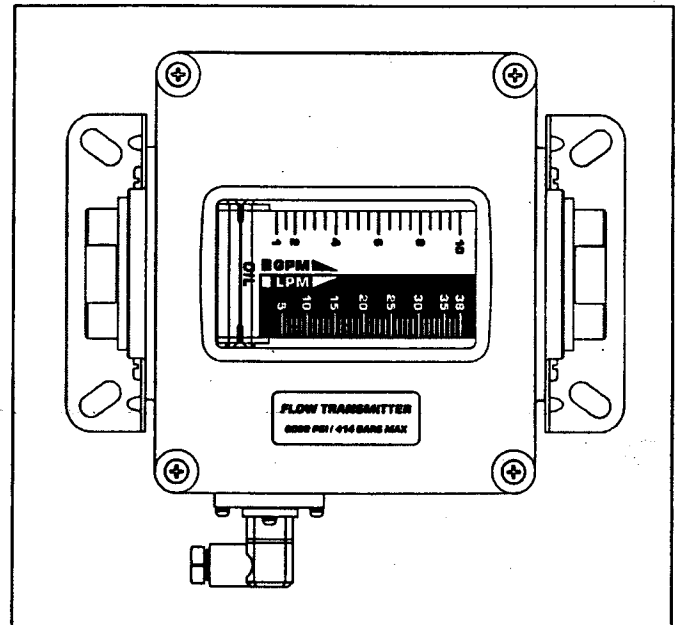

Figure 1. Flow Transmitter

- Gases (1/4" to 1/2"): 1500 psi (103 bar) maximum, with a 10:1 safety factor

Accuracy

- ± 2% of full scale

Repeatability

- ± 0.05%

Pressure Drop

- See Appendix for specific transmitter information

Flow Transmitter Installation & Maintenance Instructions

Electrical

- Power Requirement:
0-5 Vdc Output 7-28 Vdc @ 0.6W maximum
0-10 Vdc Output 12-28 Vdc @ 0.6W maximum
4-20 mA Output (see Figure 2)
- Analog Outputs: 4-20 mA into 1000 Ohms maximum; 0-5 Vdc into 10,000 Ohms minimum; 0-10 Vdc into 10,000 Ohms minimum
- Maximum Loop Load: 4-20 mA only (see Figure 2)
- Circuit Protection: Reverse polarity and current limiting
- Sensitivity: Infinite
- Response Time: 0.1 second
- Transmission Distance: 4-20 mA limited by cable resistance; 0-5 Vdc 1000 feet (300 m) maximum; 0-10 Vdc 1000 feet (300 m) maximum
- Isolation: Inherently isolated from the piping system

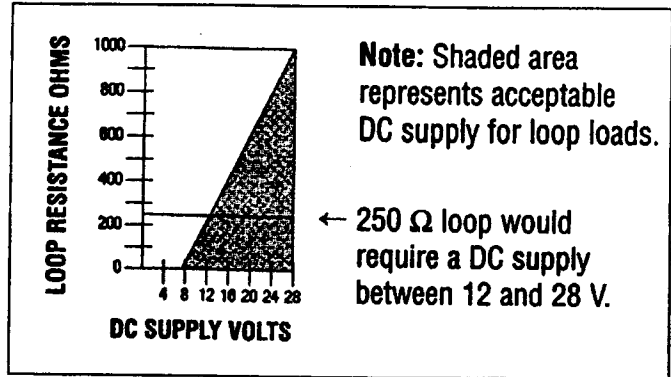
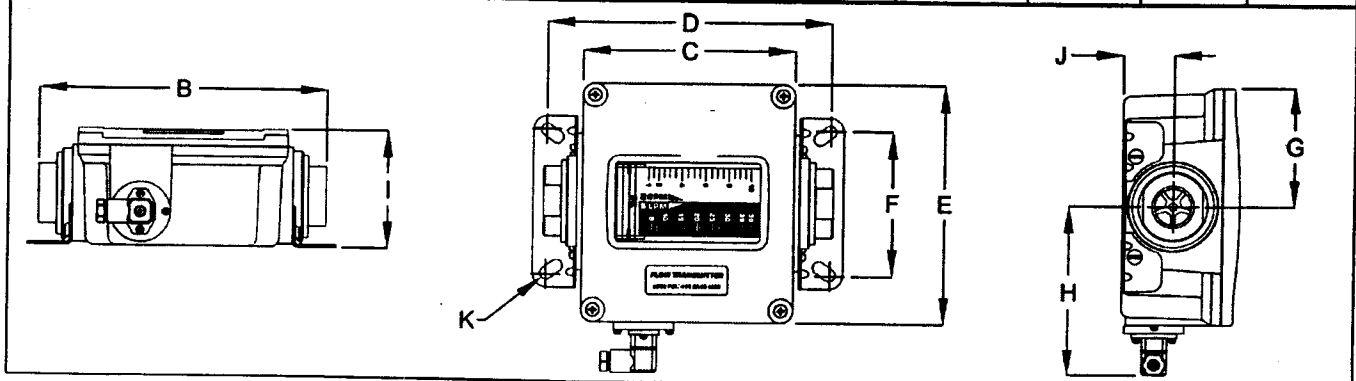

Figure 2. Load Limitations (4-20 mA Output Only)

Dimensions

A Nominal Port Size	B Length in. (mm)	C Length in. (mm)	D Length in. (mm)	E Width in. (mm)	F Width in. (mm)	G Width in. (mm)	H Width in. (mm)	I Depth in. (mm)	J Offset in. (mm)	K Hole Dia. in. (mm)
1/4 (SAE 6)	6.60 (168)	5.27 (134)	6.41 (163)	6.00 (152)	3.23 (82)	3.00 (76)	4.20 (107)	2.94 (75)	1.51 (38)	.31 (8)
1/2 (SAE 10)	6.60 (168)	5.27 (134)	6.41 (163)	6.00 (152)	3.23 (82)	3.00 (76)	4.20 (107)	2.94 (75)	1.51 (38)	.31 (8)
3/4 (SAE 12)	7.20 (183)	5.27 (134)	7.04 (179)	6.00 (152)	3.60 (91)	3.00 (76)	4.20 (107)	2.94 (75)	1.27 (32)	.31 (8)
1 (SAE 16)	7.20 (183)	5.27 (134)	7.04 (179)	6.00 (152)	3.60 (91)	3.00 (76)	4.20 (107)	2.94 (75)	1.27 (32)	.31 (8)
1-1/4 (SAE 20)	12.20 (310)	10.68 (271)	11.65 (296)	7.63 (194)	4.84 (123)	3.82 (97)	5.02 (128)	4.50 (114)	2.20 (56)	.31 (8)
1-1/2 (SAE 24)	12.20 (310)	10.68 (271)	11.65 (296)	7.63 (194)	4.84 (123)	3.82 (97)	5.02 (128)	4.50 (114)	2.20 (56)	.31 (8)



III. INSTALLATION

This unit should be installed and serviced by technically qualified personnel trained in maintaining industrial class flow instrumentation and processing equipment.

⚠ CAUTION

This transmitter may contain residual amounts of test fluid at the time of shipment. This fluid should be removed prior to installation as the fluid may be incompatible or hazardous with some liquids or gasses. Failure to follow these instructions could result in damage to the equipment.

⚠ CAUTION

This standard transmitter is unidirectional. Attempts to flow fluids in the opposite direction of the flow arrow will result in the meter acting as a check valve, creating a deadheading situation. If the differential pressure magnitude is great enough, damage to the internal parts of the meter will result.

⚠ WARNING

Disconnect electrical power before opening wiring enclosure. Failure to follow these instructions could result in serious personal injury or death and/or damage to the equipment.

⚠ WARNING

All wiring should be installed in accordance with the National Electrical Code and must conform to any applicable state and local codes. Failure to follow these instructions could result in serious personal injury or death and/or damage to the equipment.

⚠ CAUTION

Air/gas transmitters are NOT oxygen cleaned.

Installation Recommendations

The transmitter is a simple device to install. However, the following measures are recommended for reliable, trouble-free operation:

Do - Align pipe accurately. Piping should be accurately aligned and of correct length. The high pressure body of the transmitter can withstand shock and flow/pressure pulsation. However, the piping should be firmly supported by external mounting brackets, both upstream and downstream of the meter, to avoid any pipe flexing action that could reduce meter life.

Do - Use rigid mounting. If the transmitter inlet or outlet are to be rigidly mounted, and the opposing port is to be connected to flexible hose, the end connected with the flexible hose must be rigidly mounted.

Do - Use Teflon® tape for sealing NPT fittings.

Do - Install unions. Install a union near the inlet or outlet of the transmitter. This will facilitate quick, easy removal and inspection during periodic maintenance procedures.

Do - Mount the transmitter either horizontally or vertically (flow arrow pointing to either side or straight up). If the transmitter must be mounted inverted, special inverted scales are available from the factory.

Do - Ensure the fluid is traveling in the direction of the flow arrow (Figure 5).

Do - Use at least a 200 mesh (74 micron) filter. The transmitter will allow particulate to pass that would jam most valves and flow controls. Systems that do not have filtration should be equipped with at least a 200 mesh (74 micron) filter. Most hydraulic systems already have much finer filtration. Dirt, ferrous metal or sealing agents, such as Teflon tape may lodge and cause malfunction. If the transmitter is jammed at a fixed position, follow cleaning and maintenance instructions.

Don't - Use thread locking compounds as thread sealant.

Don't - Install the transmitter near turbulence producing fittings such as elbows, reducers, close coupled valves, etc. The transmitter does not require flow straighteners or special lengths of straight inlet/outlet piping to stabilize turbulent flow patterns. However, to assure maximum operational reliability, avoid installation of elbows, valves and/or reducers immediately adjacent to the transmitter inlet.

Don't - Install the transmitter near fast-acting valves. Fast-acting valves have the potential to create high magnitude hydraulic pressure spikes. These spikes can damage the internal components of the transmitter, resulting in inaccuracies or malfunction.

Don't - Allow unidirectional transmitters to be operated against the direction of the flow arrow. The standard transmitter is an unidirectional flow transmitter. The piston acts as a check valve to block flow in the reverse direction. This causes an excessive pressure differential, which can result in damage to internal transmitter components.

Flow Transmitter Installation & Maintenance Instructions

Electrical Connections

Cable may be shortened or lengthened as required by installation. The cable is soldered directly to the electrical connector at the factory.

Cable replacement requires disassembly of the electrical connector.

Schematics

The transmitter can be wired in various configurations to allow interface with many different types of data collection and control instrumentation.

Schematics 1 & 2 represent typical wiring for a target powered by either AC power or DC supply. Schematics 3 & 4 will be utilized when the flow transmitter is operated with loop-powered process indicators or data loggers that do not have external sensor excitation available.

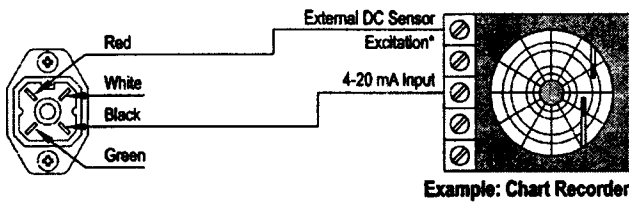

Schematic 1: 4-20 mA connection using target power supply.

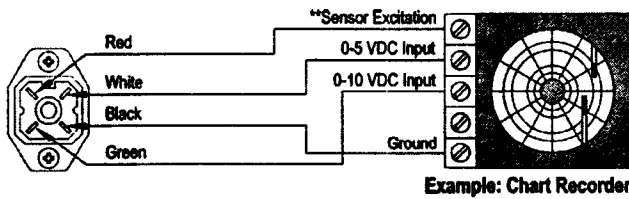

Schematic 2: 0-5 Vdc or 0-10 Vdc connection using target power supply.

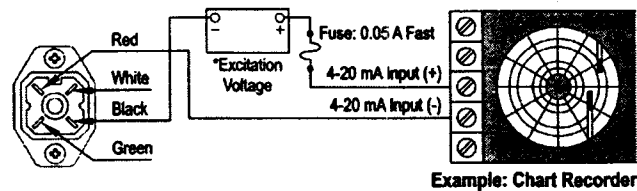

Schematic 3: 4-20 mA connection using external power supply.

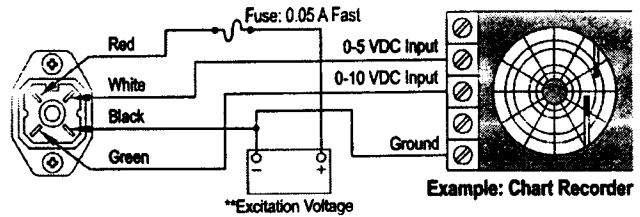

Schematic 4: 0-5 Vdc or 0-10 Vdc connection using external power supply

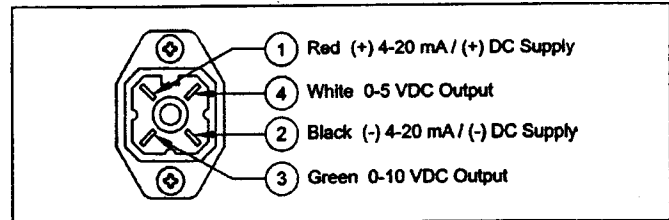

Figure 3. Electrical 4-Pin Connection

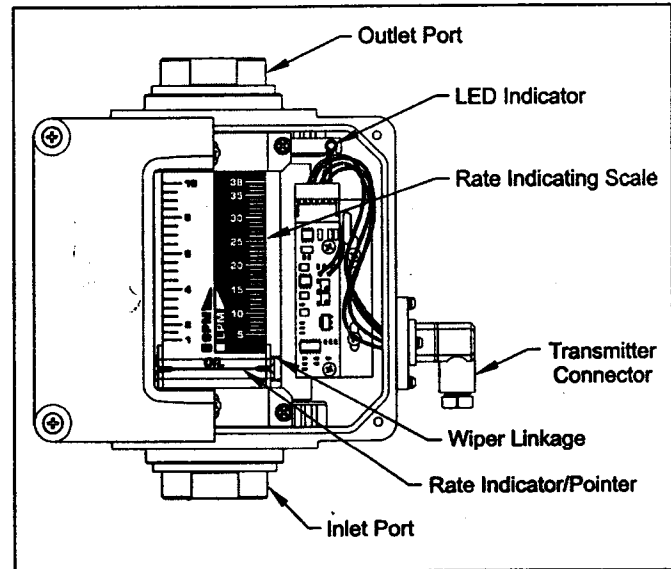

Figure 4. Terminology

⚠ CAUTION

The flow transmitter is designed to operate only one of its three outputs at a time (i.e. 0-5 Vdc or 0-10 Vdc or 4-20 mA). Please consult factory to configure multiple outputs.

Flow Transmitter Installation & Maintenance Instructions

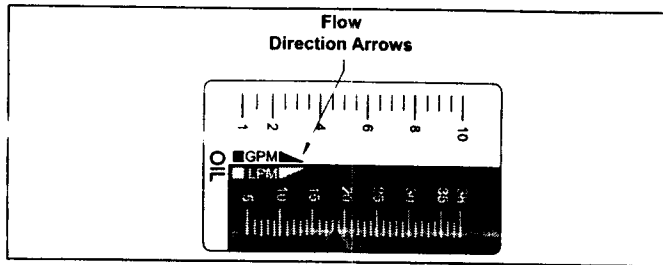

Figure 5. Flow Direction Arrows

Installing the Transmitter

1. Disconnect electrical power from the target system before making or changing any transmitter connections.
2. Use 0.05A fast acting fuse if non-current limited power sources are utilized.
3. Terminate cable shield connection at either DC ground or Earth ground.
4. Mount the transmitter so fluid is traveling in the direction of the flow arrow. See Figure 5.
5. Install unit in desired location. Use wrench on transmitter flats to hold the unit in place during installation. DO NOT TURN the transmitter using the wrench. See Figure 6.
6. After installation, rotate transmitter by hand to view flow scale. See Figure 7.

IV. OPERATION

NOTE: Refer to the Appendix for application information and fluid charts.

OFFSET & SPAN Adjustment (Figure 8)

The OFFSET controls the 4mA. Turning the OFFSET control clockwise will increase the 4mA setting at zero flow rate. The OFFSET control *does not* influence the 0-5 Vdc or 0-10 Vdc outputs. If the transmitter is not providing an output that is within 20 mV of zero, when the flow is zero, consult the factory for instructions.

The SPAN control is used to set 20mA, 5 Vdc or 10 Vdc at the transmitter maximum flow rate. Turning the SPAN control clockwise will increase the current/voltage output at flow rates that are greater than zero.

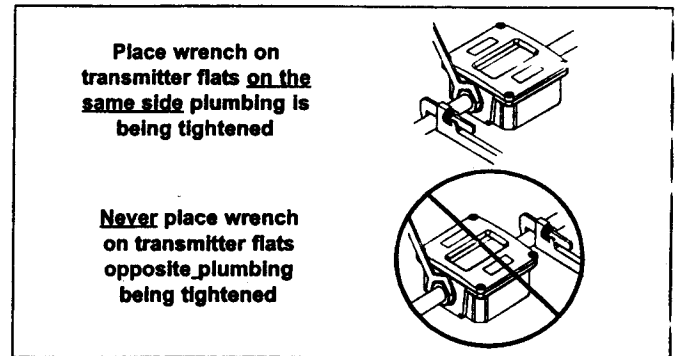

Figure 6. Installing Transmitter

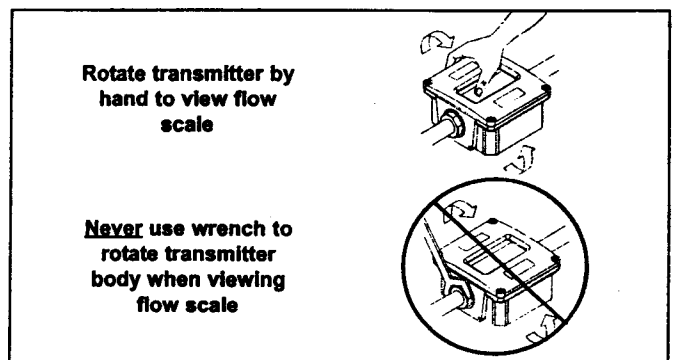

Figure 7. Rotating Transmitter

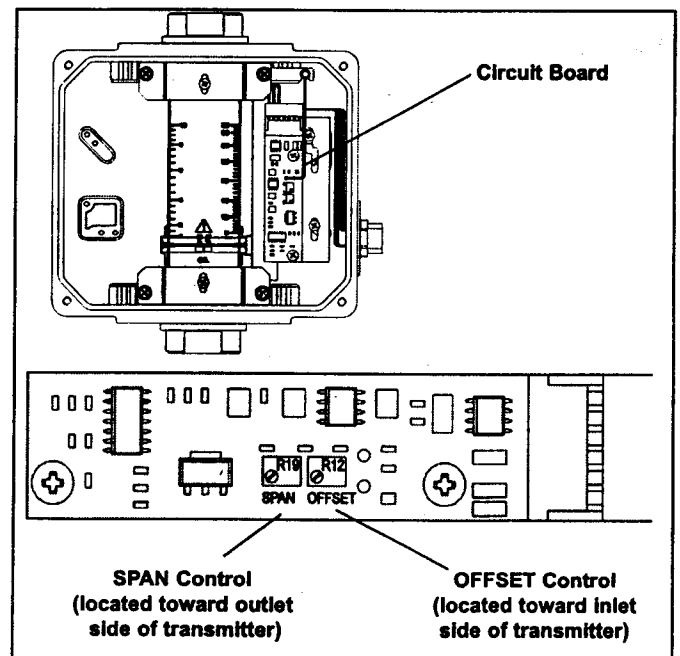

Figure 8. Transmitter Adjustments

Flow Transmitter Installation & Maintenance Instructions

▲ WARNING

Disconnect electrical power before removing transmitter cover. Failure to follow these instructions could result in serious personal injury or death and/or damage to the equipment.

1. Remove cover screws and front cover.
2. Locate the OFFSET and SPAN controls on the circuit board (Figure 8).
3. Turn the adjustment screws to adjust the electrical output to meet your application requirements.
4. Install the cover gasket and front cover and secure with screws. To properly seat the cover gasket, tighten cover screws in a criss-cross pattern as shown in Figure 9.

V. MAINTENANCE

Cartridge Cleaning (Figures 4 & 10)

▲ WARNING

Before attempting to remove the transmitter from the line, check the system to confirm that the line pressure has been reduced to zero PSI. Failure to follow these instructions could result in serious personal injury or death and/or damage to the equipment.

1. Disconnect the transmitter cable.
2. Remove the transmitter from the line. Remove excess piping from transmitter.

NOTE: It is not necessary to remove the aluminum housing from the transmitter to remove it from the line.

3. Thoroughly wipe off the entire transmitter surface using mild detergent or isopropyl alcohol.

▲ CAUTION

Do not use aromatic hydrocarbons, halogenated hydrocarbons, ketones or Ester based fluids on polycarbonate lens. Failure to follow these instructions could result in damage to the transmitter.

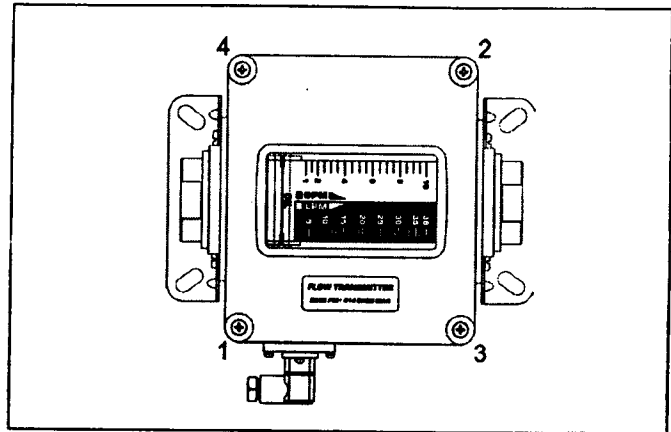

Figure 9. Cover Screw Tightening Sequence

4. Remove the inlet port cap, wave spring, retaining ring, and cone assembly from the transmitter body (Figure 10).
5. Gently push the body towards the outlet port while holding rate indicator/pointer/wiper linkage in place.

NOTE: Be careful not to damage the wiper linkage.

6. The piston, inner magnet and transmitter spring are secured within the transmitter body with a retaining ring. Remove the retaining ring with a small screwdriver, then the internal components can be removed from the body (Figure 10).

NOTE: If internal parts do not slide freely from cartridge, use a wooden dowel inserted into the outlet port of the transmitter to push parts out.

7. Place all parts on a clean work surface. Clean and inspect all parts. Replace any that appear worn or damaged.

Check inlet port O-ring for damage and replace if required.

8. Reassemble the transmitter by inserting the transmitter spring into the body, followed by the piston/inner magnet assembly. A slight compression of the piston against the spring is required during installation of the retaining ring.
9. Gently push body assembly into the outlet end

Flow Transmitter Installation & Maintenance Instructions

of the transmitter enclosure while holding and aligning the rate indicator/pointer and wiper linkage in position. The flat surface of the body outlet port should be flush with the transmitter enclosure opening.

NOTE: Wiper linkage must be coupled to the rate indicator before inserting the cartridge into the housing.

10. With the transmitter positioned vertically on a flat surface, inlet port facing up, install the transmitter cone assembly and wave spring into the body and secure with the inlet port end cap.
11. Reinstall transmitter to the line. Reconnect electrical power.

Quick Re-Coupling

This piston-type variable-area flow transmitter is inherently less sensitive to shock and vibration than other variable-area designs. The unique magnetic coupling also eliminates the need for mechanical linkages that can wear or loosen over the functional life of the transmitter.

However, on occasion, a pressure spike or extreme flow surge can cause the piston to move at such rapid speed that it disconnects the piston (magnetic coupling) from the external magnetic indicator ring. If this occurs, use one of these procedures to re-couple the piston magnet and the external indicator ring.

- If the system permits, simply change flow rate from "no flow" to "full flow" allowing the moving piston to magnetically re-couple to the indicator ring.
- Remove cover and manually re-attach external flow indicator to internal magnet/piston assembly.
- For rigorous cyclical applications where decoupling may occur frequently, consult the technical services staff for further recommendations.

VI. TROUBLESHOOTING

NOTE: Troubleshooting LED is located inside transmitter enclosure. Refer to Figure 4 for location.

The green LED does not illuminate.

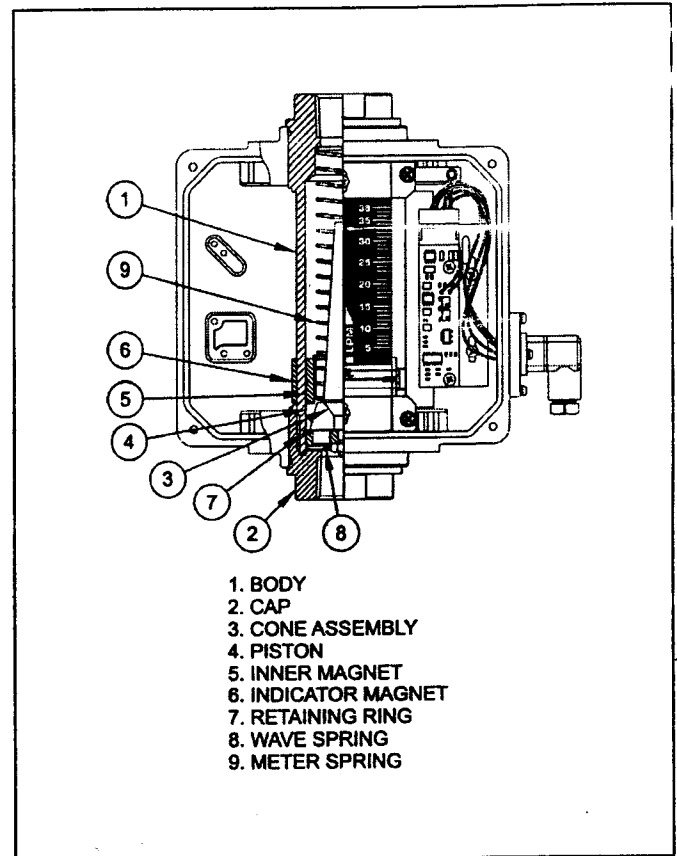

Figure 10. Cartridge Components

- Power supply polarity is reversed.
- Voltage not applied to the red and black wires of the flow Transmitter (7-28 Vdc).
- Loop resistance is greater than maximum allowed.
- Electrical connection to the transmitter not properly secured.
- Broken wire/solder joint in the electrical connector.

The green LED illuminates but output does not vary with flow rate.

- Rate indicator/pointer is not indicating flow. Possible magnetic decoupling has occurred.
- A wiring or configuration error was made in the target device.

Flow Transmitter Installation & Maintenance Instructions

The green LED illuminates but output is greater than the span.

- The connection between the linear resistor element and the transmitter PCB is broken.
- The contact between the linear resistor and the rate indicator/pointer wiper is broken.

The green LED illuminates but output is not proportional to rate of flow.

- The DC power supply is inadequate for the output voltage/loop current requirement.
- For 4-20 mA operation—the loop resistance in the target device is too great.
- Viscosity of the liquid is greater than specifications allow.
- The SPAN control on the transmitter circuit board requires adjustment.

The green LED illuminates but output is erratic—not tracking the rate indicator/pointer.

- Transmitter wires have been run adjacent to or in the same conduit with noisy AC power lines.
- The cable shield connection is not secured to either DC or Earth ground.

VII. APPENDIX

Application Information – Liquid Viscosity Effect (SUS/cSt)

The design utilizes a precision machined, sharp-edged orifice and biasing calibration spring that assures operating stability and accuracy over the wide viscosity range common to many fluids. Generally, high flow models of each transmitter size provide good accuracy over a viscosity range of 40 to 500 SUS (4.2 to 109 cSt).

Density Effect (specific gravity)

Any fluid density change from stated standards has a proportion effect on transmitter accuracy. Special scales can be supplied if actual specific gravity decreases accuracy beyond application limits. Corrections for more or less dense fluids can be made to standard scales using the following correction factor:

$$\frac{1.0}{\sqrt{\text{Specific Gravity}}} \text{ for water/water-based transmitters}$$

$$\frac{0.876}{\sqrt{\text{Specific Gravity}}} \text{ for petroleum-based transmitters.}$$

Application Information – Pneumatic

NOTE: Pressure and temperature readings must be taken at the flow transmitter inlet to ensure accurate correction factors.

The pneumatic flow transmitter is offered with a standard graduated dual scale, calibrated for air in standard cubic feet per minute (scfm) at 1.0 s.g. (70°F @ 100 psi), and liters per second (lps) at 1.0 s.g. (21°C @ 6.9 bar).

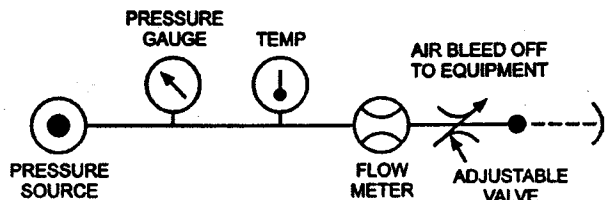

Flow Transmitter Installation & Maintenance Instructions

FLOW RATE CORRECTION FACTORS FOR GAS										
$SCFM (Actual) = \frac{SCFM (Indicated)}{f_1 \times f_2 \times f_3}$										
f_1 = conversion factor for inlet pressure f_2 = conversion factor for temperature f_3 = conversion factor for specific gravity										
PRESSURE CORRECTION FACTOR (f_1)										
Operating Pressure (psig)										
psig	25	50	75	100	125	150	175	200	225	250
f_1	1.700	1.331	1.131	1.00	.902	.835	.778	.731	.692	.658
$f_1 = \sqrt{\frac{114.7}{14.7 + psig}}$										
TEMPERATURE CORRECTION FACTOR (f_2)										
°F	10	30	50	70	90	110	130	150	170	190
f_2	.942	.962	.981	1.00	1.018	1.037	1.055	1.072	1.090	1.107
$f_2 = \sqrt{\frac{460 + ^\circ F}{530}}$										
SPECIFIC GRAVITY CORRECTION FACTOR (f_3)										
$f_3 = \sqrt{\text{Specific Gravity}}$										

FLUID SELECTION CHART	Air / Gas	Specific Gravity	Correction Factor Std. Scale	Material										
				Aluminum	Brass	T316 SSt	T313 SSt	Viton	El R	Polycarbonate	Nylon	Pyrex™		
Air	1.0	1.000	R	R	R	R	R	R	R	R	R	R	R	R
Argon (A)	1.36	1.175	R	R	R	R	R	R	R	R	R	R	R	R
Carbon Dioxide (CO ₂)	1.53	1.237	R	R	R	R	R	R	R	R	R	R	R	R
Freon 11 (CCl ₃ F)	4.92	2.218	R	R	R	R	R	R	R	R	R	R	R	R
Freon 12 (CCl ₂ F ₂)	4.26	2.060	R	R	R	R	R	R	R	R	R	R	R	R
Helium (HE)	0.14	0.374	R	R	R	R	R	R	R	R	R	R	R	R
Hydrogen (H ₂)	0.07	0.265	R	R	R	R	R	R	R	R	R	R	R	R
Natural Gas	0.60	0.775	C	C	R	C	R	N	C	R	R	R	R	R
Nitrogen (N ₂)	0.97	0.985	C	C	R	R	R	R	R	C	R	R	R	R
Oxygen (O ₂)	1.10	1.049	R	R	R	R	R	R	R	R	R	R	R	R
Propane (C ₃ H ₈)	1.57	1.253	R	R	R	R	R	N	N	R	R	R	R	R

R = Recommended
 N = Not recommended
 C = Consult Factory

Flow vs. Pressure Drop

Water Based Fluids

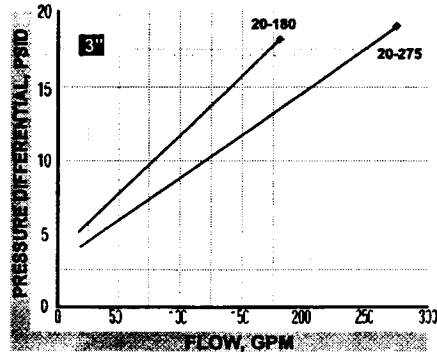
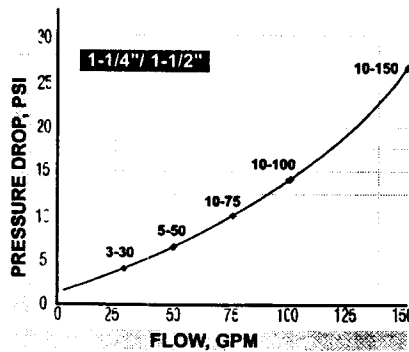
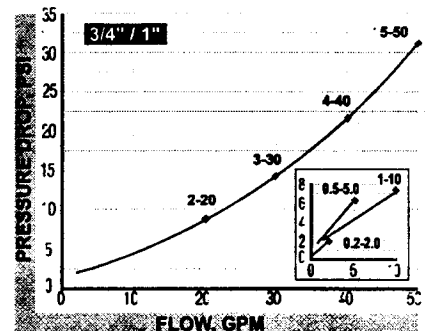
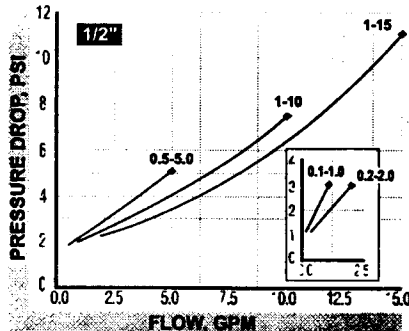
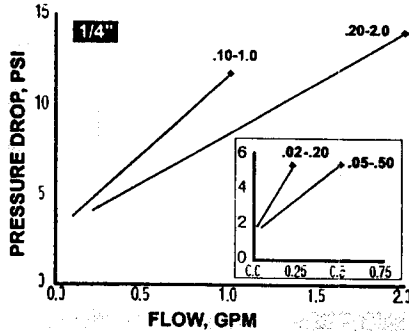

Flow Transmitter Installation & Maintenance Instructions

Water Based Fluids (continued)

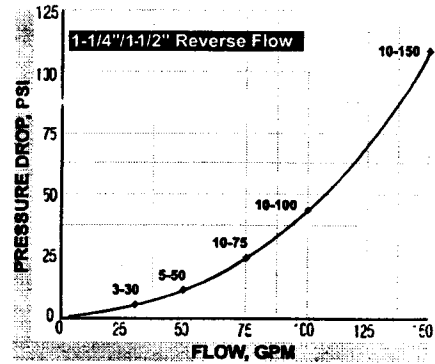
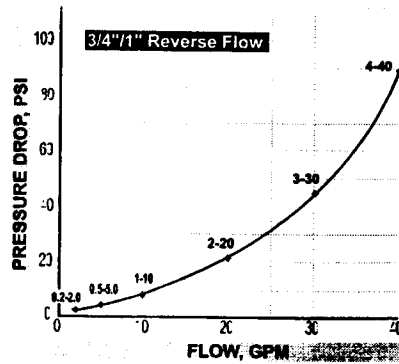
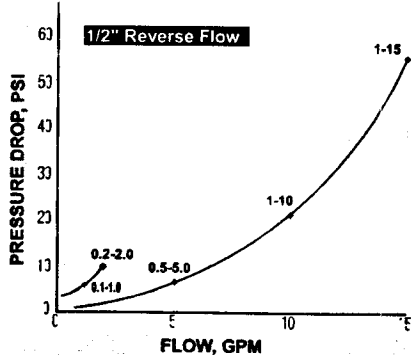

Water

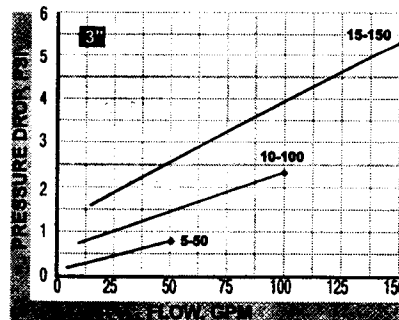
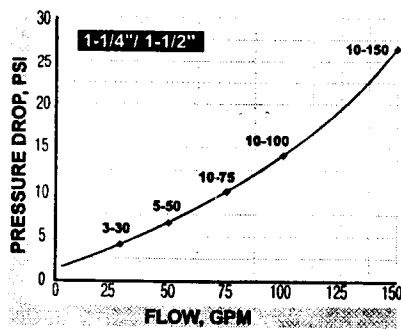
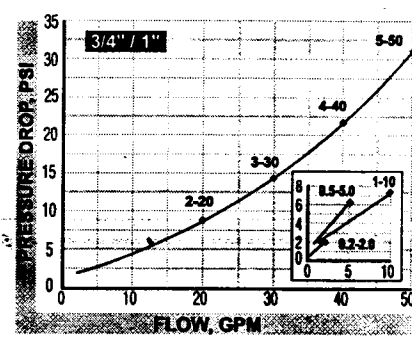
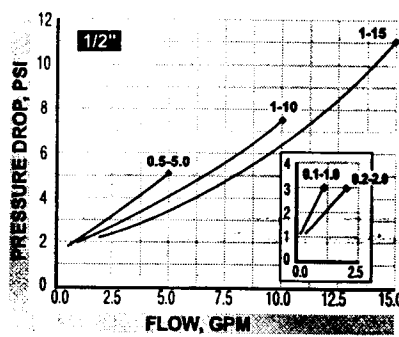
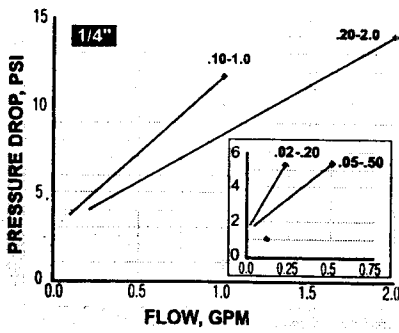

Flow Transmitter Installation & Maintenance Instructions

Caustic and Corrosive Liquids

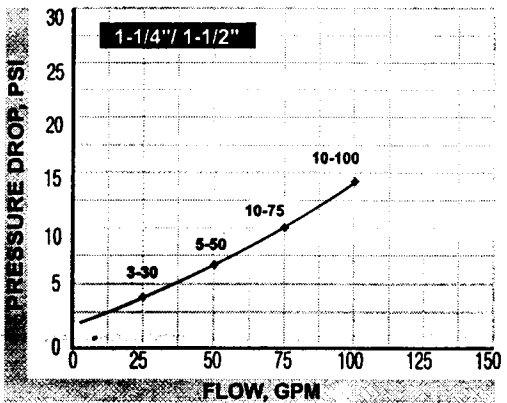
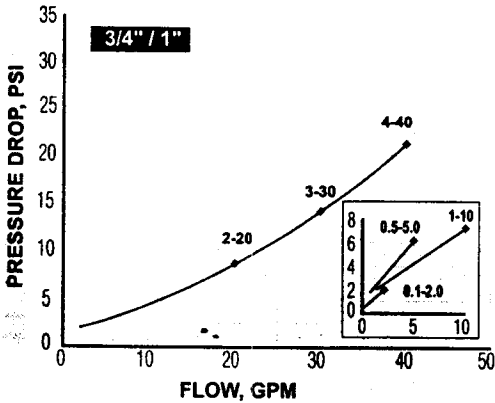
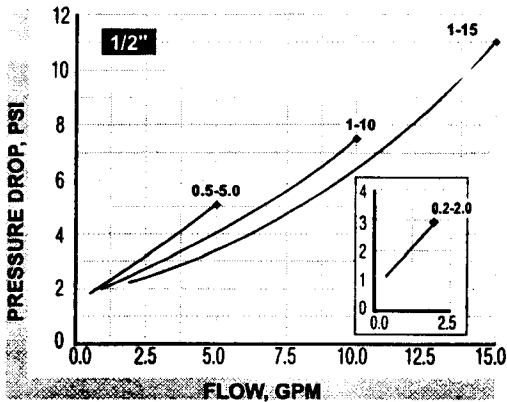
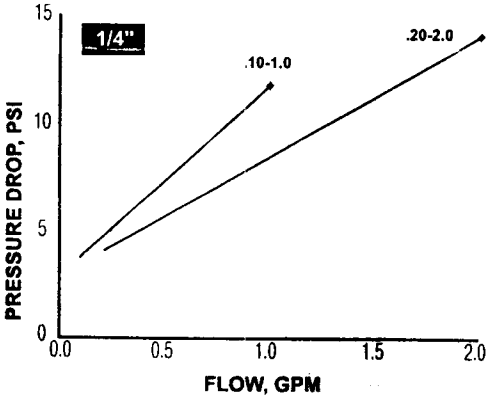

Flow Transmitter Installation & Maintenance Instructions

Petroleum Fluids

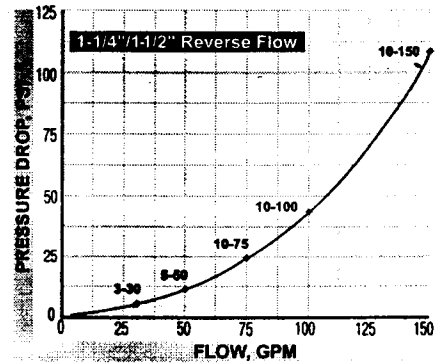
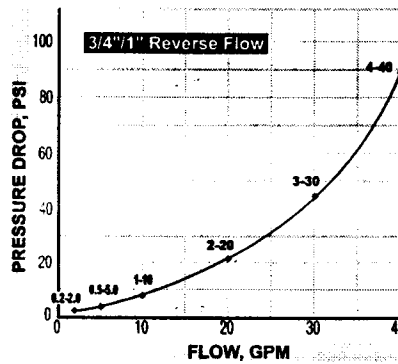
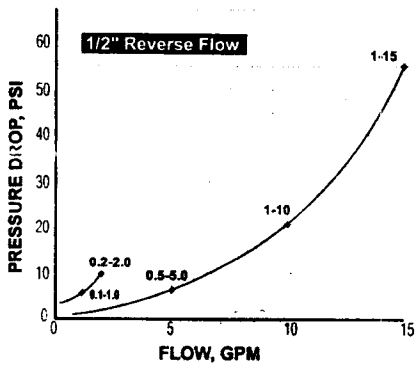
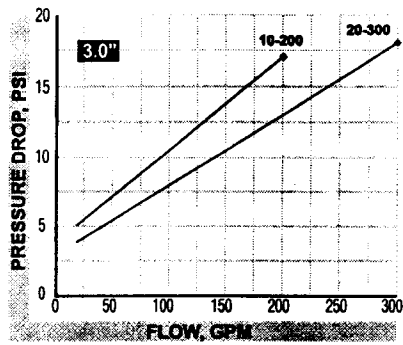
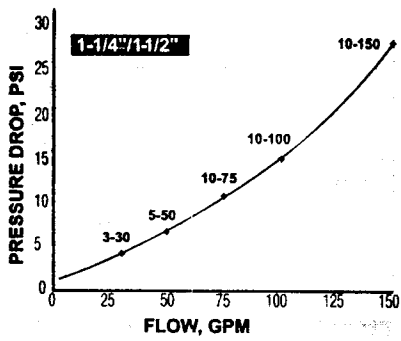
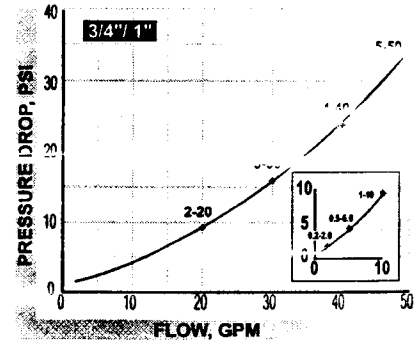
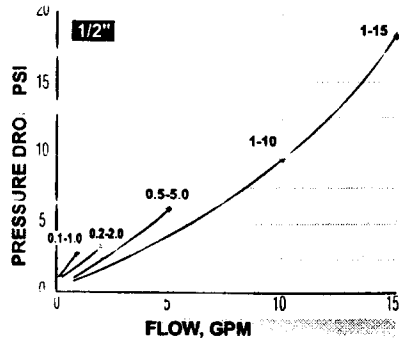
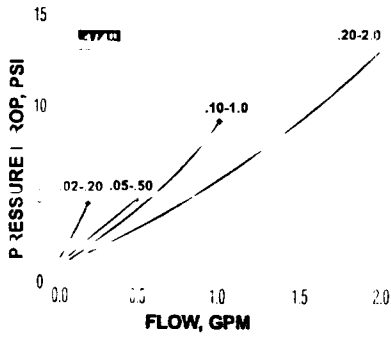

Flow Transmitter Installation & Maintenance Instructions

Phosphate Ester

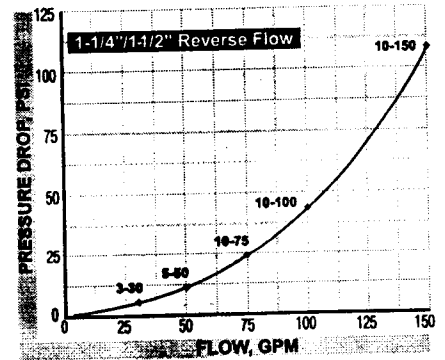
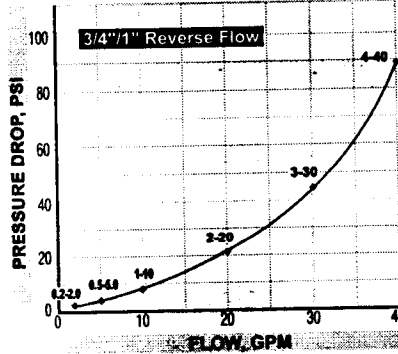
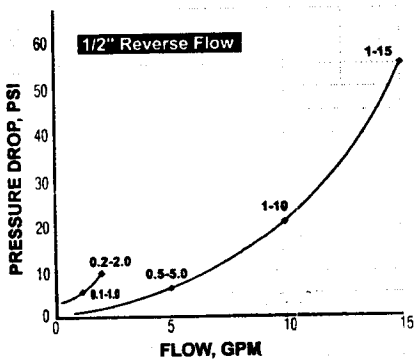
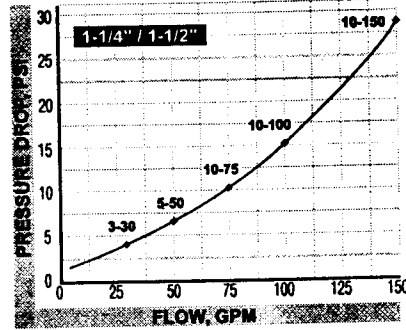
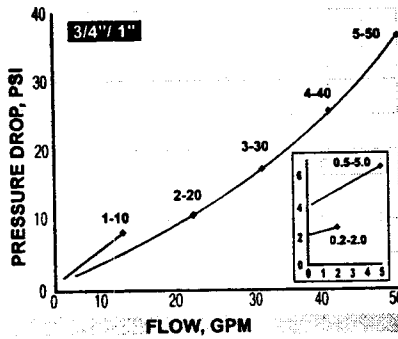
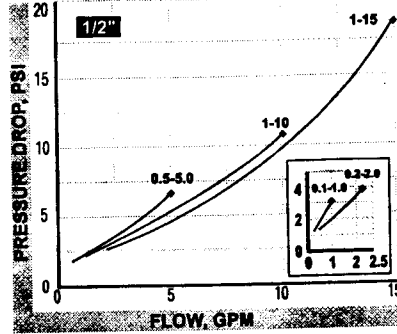
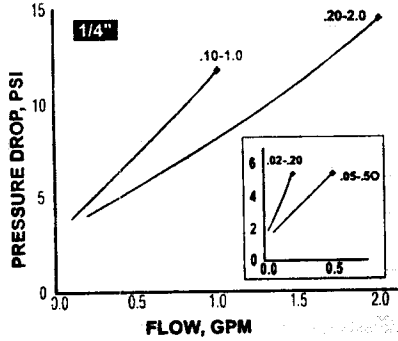

NOTE: Calibrated with 140 SUS (32 cSt), 0.876 s.g. hydraulic oil.
Flow meter scales are corrected for specific gravity to 1.18.

Flow Transmitter Installation & Maintenance Instructions

A.P.I. Oil

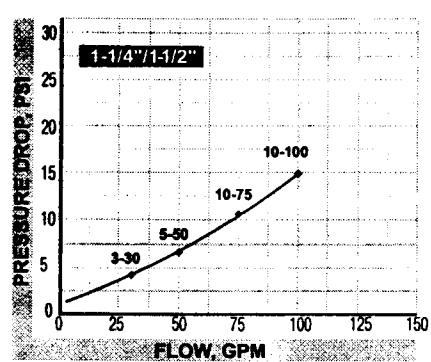
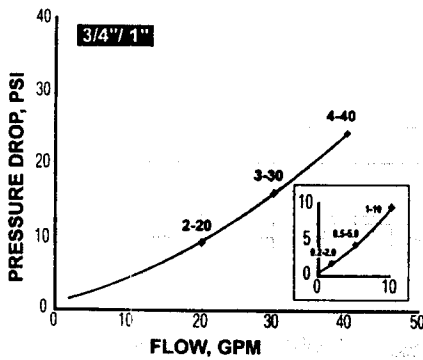
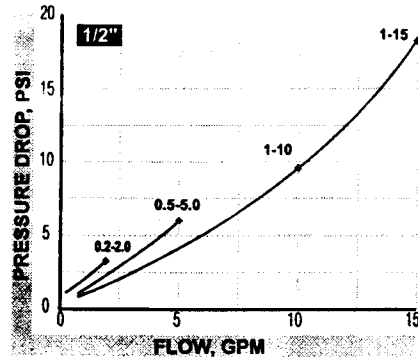
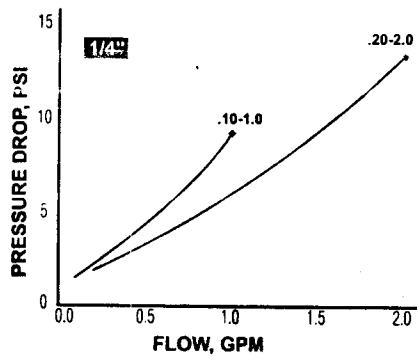

Air / Caustic and
Corrosive Gases

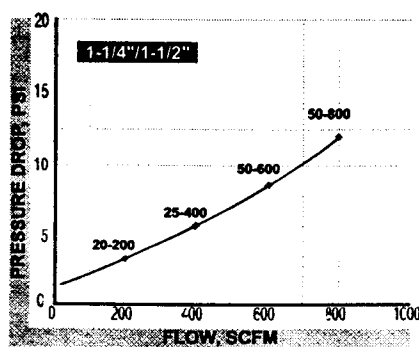
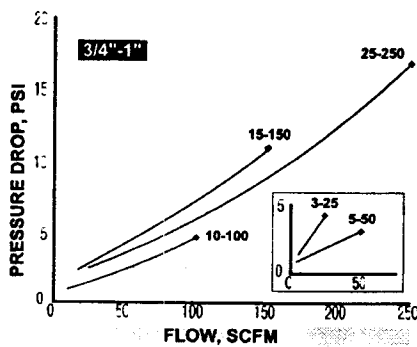
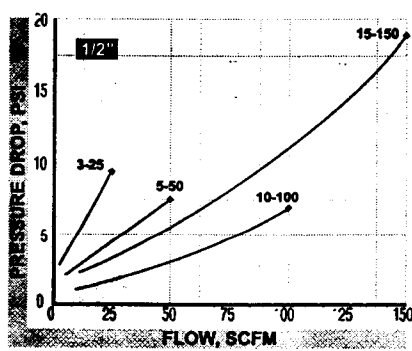
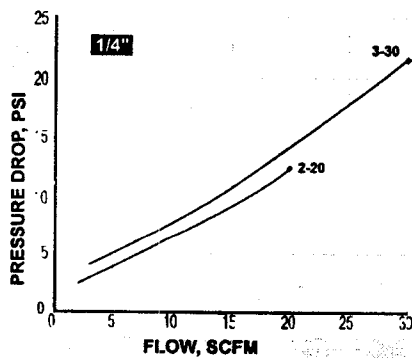

Flow Transmitter Installation & Maintenance Instructions

Air / Compressed Gases

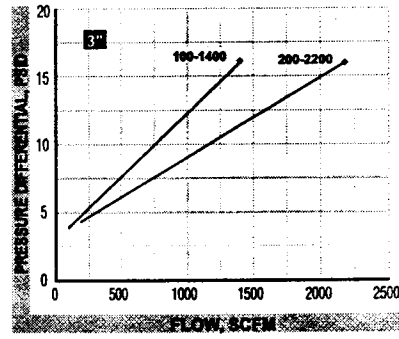
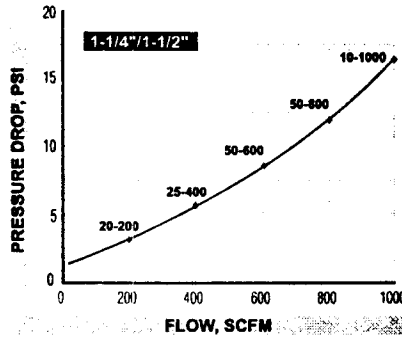
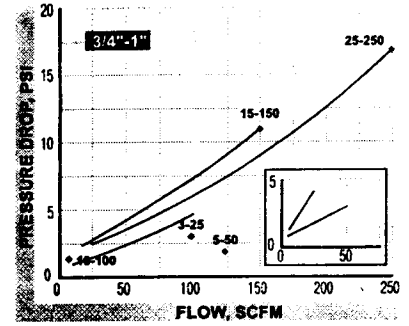
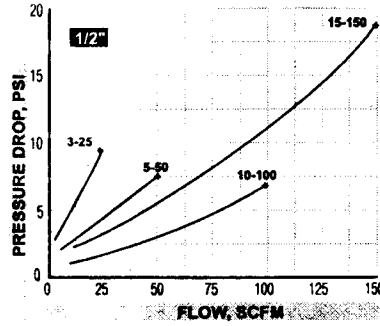
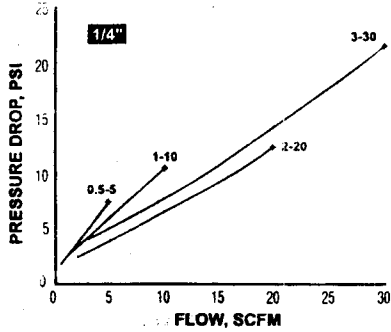

Flow Transmitter Installation & Maintenance Instructions

Air / Compressed Gases

