



**omega.com**

CEOMEGA

OMEGAnet<sup>®</sup> On-Line Service  
www.omega.com

Internet e-mail  
info@omega.com

**Servicing North America:**

**USA: ISO 9001 Certified**  
One Omega Drive, Box 4047  
Stamford CT 06907-0047  
Tel: (203) 359-1660  
FAX: (203) 359-7700  
e-mail: info@omega.com

**Canada:**  
976 Bergar  
Laval (Quebec) H7L 5A1, Canada  
Tel: (514) 856-6928  
FAX: (514) 856-6886  
e-mail: info@omega.ca

**For immediate technical or application assistance:**

**USA and Canada:**  
Sales Service: 1-800-826-6342 / 1-800-TC-OMEGA  
Customer Service: 1-800-622-2378 / 1-800-622-BEST  
Engineering Service: 1-800-872-9436 / 1-800-USA-WHEN  
TELEX: 996404 EASYLINK: 62968934  
CABLE: OMEGA

**Mexico:**  
En Español: (001) 203-359-7803  
FAX: (001) 203-359-7807  
e-mail: espanol@omega.com  
info@omega.com.mx

**Servicing Europe:**

**Benelux:**  
Postbus 8034, 1180 LA Amstelveen  
The Netherlands  
Tel: +31 (0)20 3472121 FAX: +31 (0)20 6434643  
Toll Free in Benelux: 0800 0993344  
e-mail: sales@omegaeng.nl

**Czech Republic:**  
Frystatska 184/46, 733 01 Karvina, Czech Republic  
Tel: +420 (0)59 6311899 FAX: +420 (0)59 6311114  
Toll Free: 0800-1-66342 e-mail: info@omegashop.cz

**France:**  
11, rue Jacques Cartier, 78280 Guyancourt, France  
Tel: +33 (0)1 61 37 29 00 FAX: +33 (0)1 30 57 54 27  
Toll Free in France: 0800 466 342  
e-mail: sales@omega.fr

**Germany/Austria:**  
Daimlerstrasse 26, D-75392  
Deckenpfronn, Germany  
Tel: +49 (0)7056 9398-0 FAX: +49 (0)7056 9398-29  
Toll Free in Germany: 0800 639 7678  
e-mail: info@omega.de

**United Kingdom: ISO 9002 Certified**  
One Omega Drive  
River Bend Technology Centre  
Northbank, Irlam  
Manchester M44 5BD United Kingdom  
Tel: +44 (0)161 777 6611 FAX: +44 (0)161 777 6622  
Toll Free in United Kingdom: 0800-488-488  
e-mail: sales@omega.co.uk

It is the policy of OMEGA to comply with all worldwide safety and EMC/EMI regulations that apply. OMEGA is constantly pursuing certification of its products to the European New Approach Directives. OMEGA will add the CE mark to every appropriate device upon certification. The information contained in this document is believed to be correct, but OMEGA Engineering, Inc. accepts no liability for any errors it contains, and reserves the right to alter specifications without notice.  
**WARNING:** These products are not designed for use in, and should not be used for, human applications.

**TABLE OF CONTENTS**  
**PHA-51/52**

<b>SECTION</b>	<b>PAGE</b>
<b>SECTION 1 INTRODUCTION</b> .....	1
1.1 General Description .....	1
<b>SECTION 2 INSTALLATION</b> .....	1
2.1 Unpacking .....	1
2.2 Mounting Procedure .....	2
2.3 Electrical Connections .....	2
2.3.1 Input Signal .....	2
2.3.2 Analog Output .....	5
2.3.3 Relay Outputs .....	5
2.3.4 Line Power .....	5
<b>SECTION 3 OPERATION</b> .....	6
3.1 Controls and Indicators .....	6
3.2 Setting Relay Functions .....	10
<b>SECTION 4 MAINTENANCE</b> .....	11
4.1 Input Signal Wires .....	11
4.2 Relay Replacement .....	11
<b>SECTION 5 SPECIFICATIONS</b> .....	11

## **SECTION 1 INTRODUCTION**

### **1.1 GENERAL DESCRIPTION**

The OMEGA® PHA-51 and PHA-52 dual alarm modules provide an ideal way to add alarm capability to a control system loop. The module's two relays each have setpoint and deadband controls and an LED to indicate on/off relay status. Relay phasing switches individually select each relay to operate in response to increasing or decreasing input signal value. For compatibility with many systems, input levels are user selectable. The PHA-51 accepts 0 to 20 mA, 4 to 20 mA, or 0 to 5 Vdc inputs and the PHA-52 accepts 0 to 50 mV, 0 to 100 mV, and 0 to 5 Vdc.

## **SECTION 2 INSTALLATION**

### **2.1 UNPACKING**

Remove the Packing List and verify that you have received all equipment, including the following (quantities in parentheses):

PHA-51 or PHA-52 Alarm Module(1)

Operator's Manual (1)

If you have any questions about the shipment, please call the OMEGA Customer Service Department.

When you receive the shipment, inspect the container and equipment for signs of damage. Note any evidence of rough handling in transit. Immediately report any damage to the shipping agent.

---

The carrier will not honor damage claims unless all shipping material is saved for inspection. After examining and removing contents, save packing material and carton in the event reshipment is necessary.

---

## **2.2 MOUNTING PROCEDURE**

Mount in as clean and dry a location as possible where minimal mechanical vibration exists. Avoid locations where corrosive fluids may fall on the unit, or where its ambient temperature limits may be exceeded.

Refer to Figure 2-1 for mounting dimensions. Surface mount the unit, using the four 0.17 inch diameter mounting holes.

The cord grip fittings should be used where cables enter the enclosure. Holes not used for cable entry should be sealed with a plug. Use NEMA 4 rated fittings and plugs to maintain the water-tight integrity of the NEMA 4 enclosure.

## **2.3 ELECTRICAL CONNECTIONS (Refer to Figure 2-2)**

### **2.3.1 Input Signal**

Connect the 0-20 mA, 4-20 mA, 0 to 50 mV, 0 to 100 mV, or 0 to 5 Vdc signal from the measuring instrument to Terminals 2 and 3 on TB1, matching polarity as shown. Place SIGNAL IN SELECT programming switches in appropriate positions to configure module to accept input signal being used.

It is recommended that input signal wires be run in 1/2" metal conduit for protection against moisture and mechanical damage. Do not run input signal wires in the same conduit with power or control wiring ("noise" may interfere with input signal).

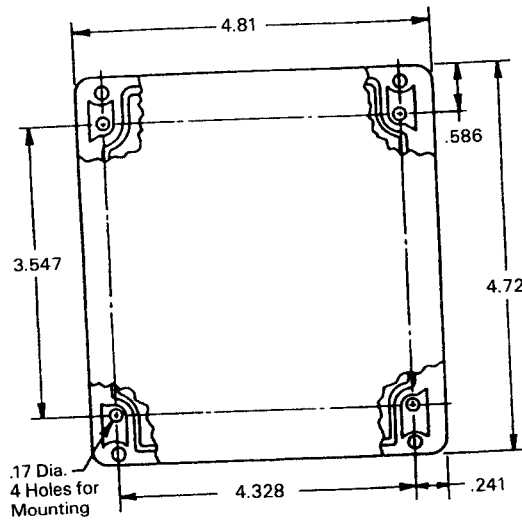

Figure 2-1 Dimensions

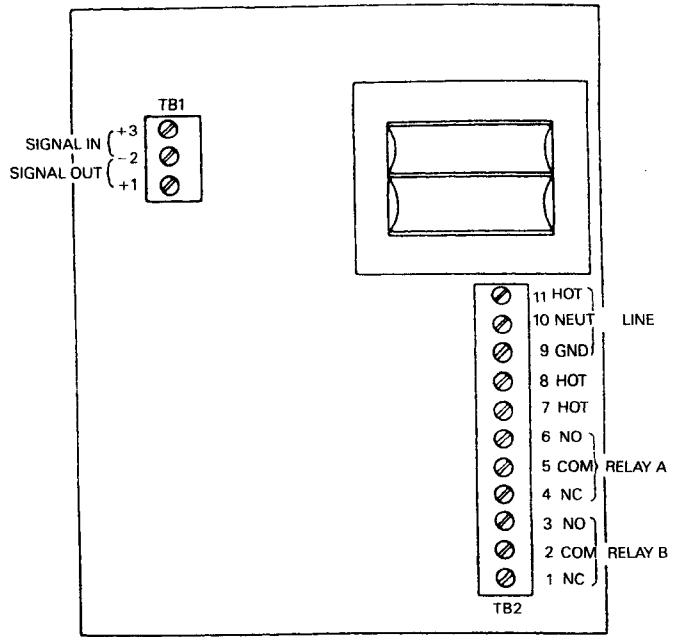

Figure 2-2 Electrical Connections

### **2.3.2 Analog Output**

A 0-1 mA/0-5 VDC analog output is provided at Terminals 1 and 2 on TB1 as a convenience to drive a recorder or other indicating device. When connecting a load, match polarity as indicated. Refer to Section 5, Specifications for load impedance limitations.

### **2.3.3 Relay Outputs**

Two SPDT relay outputs are provided on TB2. Relay outputs must be powered. The module's line power may also be used to power other devices via the relay contacts. Always check control wiring to insure that line power will not be shorted by the switching action of the relay contacts.

Do not exceed each relay's contact rating of 3A at 250 VAC. If larger currents are to be switched, use of an auxiliary relay will extend the life of the relays in the unit.

### **2.3.4 Line Power**

Connect line power to Terminals 9, 10 and 11 on TB2. Use only the standard three-wire connection. To properly ground the module, run a ground strap from Terminal 9 on TB2 to an earth ground (metal conduit, etc.).

#### **CAUTION**

Any other wiring scheme may be unsafe or cause improper operation of the instrument.



## **SECTION 3 OPERATION**

### **3.1 CONTROLS AND INDICATORS**

All controls, switches and indicators used for routine operation are described in Table 3-1. Become thoroughly familiar with the function of each item before operating the unit for the first time. Refer to Figures 3-1 and 3-2.

**TABLE 3-1  
CONTROLS AND INDICATORS**

#### **1. SIGNAL IN SELECT PROGRAMMING SWITCHES**

These four individual slide switches program the dual alarm module to accept one of the appropriate input signals. Each switch must be in the correct position shown in Figure 3-2 for the respectively designated input signal. The fourth (bottom) switch is always in the same position regardless of which input signal is used.

#### **2. ST.PT. A (B) CONTROLS**

Each continuously variable control sets the point at which its respective relay (A, B) turns on in response to increasing process variable value in "high phase" relay operation. The relay remains on whenever the process variable value is above this selected setpoint value. The control's 0-10 adjustment range represents 0 to 100% of the process variable measuring range. The opposite relay operation occurs when a "low phase" is selected with the MODE A (B) switch (see item 4).

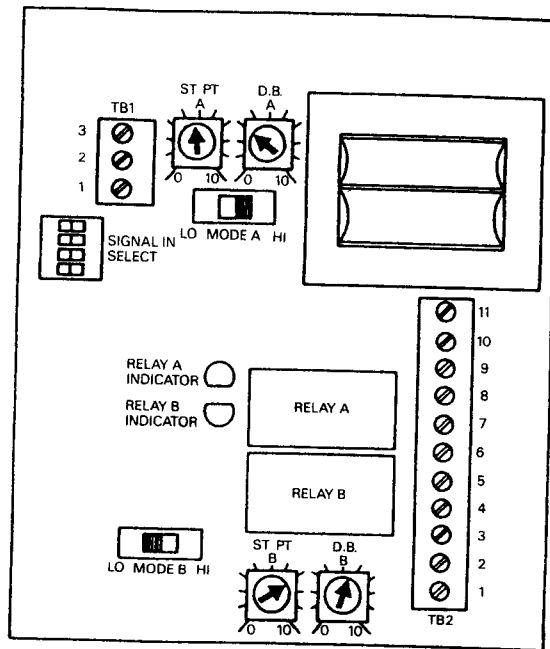
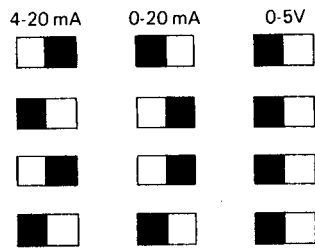
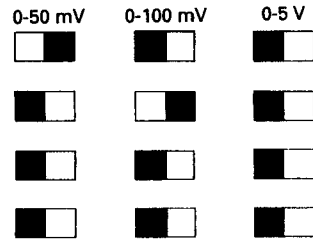

Figure 3-1 Controls Layout



**Figure 3-2 A PHA-51**  
**Signal In Select Switches**



**Figure 3-2 B PHA-52**  
**Signal In Select Switches**

**3. RELAY A (B) INDICATORS (yellow)**

Each indicator lights whenever its respective relay (A, B) turns on.

**4. MODE A (B) SWITCHES**

HI - Selects "high phase" operation for respective relay; it turns on in response to increasing process variable value.

LO - Selects "low phase" operation for respective relay; it turns on in response to decreasing process variable value.

**5. D.B. A (B) CONTROLS**

Each continuously variable control sets the point at which its respective relay (A, B) turns off when the process variable value in high phase operation decreases below the preselected setpoint value set by the ST.PT.A and ST.PT.B controls. This establishes a range or "deadband" in which the relay remains on. The control's 0-10 adjustment range represents approximately 0 to 50% of the process variable measuring range.

The opposite relay operation occurs when a "low phase" is selected with the MODE A (B) switch (see item 4).

### 3.2 SETTING RELAY FUNCTIONS

Prior to operating the PHA-51/52 for the first time, place the SIGNAL IN SELECT programming switches in their appropriate positions for the input signal being used (refer to Table 3-1 and Figure 3-2).

The procedure to set up relay phasing and a setpoint with a deadband is described with the following example. Suppose the process variable measuring range is 0-100 units and the operational requirements for relay A are:

Relay A turns on at 60 units as the process variable increases.  
Relay A turns off at 50 units as the process variable decreases below the setpoint value.

1. Assign a "high phase" to relay A. Place the MODE A switch to HI.
2. To set relay A's setpoint, make the measuring instrument's display indicate 60 units. Turn the PHA-51/52's ST.PT.A control slowly until the RELAY A INDICATOR lights (relay turns on).
3. To set relay A's deadband, turn the D.B.A control fully clockwise (right). Make the measuring instrument's display indicate 50 units and turn the D.B.A control slowly counterclockwise (left) until the RELAY A INDICATOR turns off (relay turns off).
4. Shift the measuring instrument's display reading back and forth, through the established setpoint and deadband, to verify that the relay turns on and off at these points. If further adjustment is required, repeat the steps previously described.

## SECTION 4 MAINTENANCE

### 4.1 INPUT SIGNAL WIRES

If the input signal wires have not been put in conduit or other protective means, they should be inspected every few months for physical damage. At the same time, disconnect the wires at the source and module, and check them for internal shorts with an ohmmeter.

### 4.2 RELAY REPLACEMENT

1. Remove line power from the module.
2. Unsolder and discard the defective relay.
3. Solder an equivalent relay into its respective solder pads.

## SECTION 5 SPECIFICATIONS

<b>INPUTS:</b>	PHA-51: 0 to 20 mA, 4 to 20 mA, 0 to 5 Vdc; PHA-52: 0 to 50 mV, 0 to 100 mV, 0 to 5 Vdc
<b>OUTPUTS:</b>	0 to 5 Vdc, 100 K ohms min. load; 0 to 1 mA, 100 ohms maximum
<b>POWER:</b>	100-130 Vac
<b>RELAYS:</b>	Setpoints: 0 to 100% of input signal range; Deadbands: 0 to 50% of signal input range; Contact Rating: SPDT, 3A resistive, 250 Vac maximum, 3A maximum resistive, 30 Vdc maximum.

**SPECIFICATIONS (cont'd)**

**RESPONSE TIME:** Less than 1 second to 90% of value

**DIMENSIONS:** 4 3/4" x 4 3/4" x 2 1/4"

**WEIGHT:** 1.25 lb











## WARRANTY / DISCLAIMER

OMEGA ENGINEERING, INC. warrants this unit to be free of defects in materials and workmanship for a period of **13 months** from date of purchase. OMEGA's Warranty adds an additional one (1) month grace period to the normal **one (1) year product warranty** to cover handling and shipping time. This ensures that OMEGA's customers receive maximum coverage on each product.

If the unit malfunctions, it must be returned to the factory for evaluation. OMEGA's Customer Service Department will issue an Authorized Return (AR) number immediately upon phone or written request. Upon examination by OMEGA, if the unit is found to be defective, it will be repaired or replaced at no charge. OMEGA's WARRANTY does not apply to defects resulting from any action of the purchaser, including but not limited to mishandling, improper interfacing, operation outside of design limits, improper repair, or unauthorized modification. This WARRANTY is VOID if the unit shows evidence of having been tampered with or shows evidence of having been damaged as a result of excessive corrosion; or current, heat, moisture or vibration; improper specification; misapplication; misuse or other operating conditions outside of OMEGA's control. Components which wear are not warranted, including but not limited to contact points, fuses, and triacs.

OMEGA is pleased to offer suggestions on the use of its various products. However, OMEGA neither assumes responsibility for any omissions or errors nor assumes liability for any damages that result from the use of its products in accordance with information provided by OMEGA, either verbal or written. OMEGA warrants only that the parts manufactured by it will be as specified and free of defects. OMEGA MAKES NO OTHER WARRANTIES OR REPRESENTATIONS OF ANY KIND WHATSOEVER, EXPRESS OR IMPLIED, EXCEPT THAT OF TITLE, AND ALL IMPLIED WARRANTIES INCLUDING ANY WARRANTY OF MERCHANTABILITY AND FITNESS FOR A PARTICULAR PURPOSE ARE HEREBY DISCLAIMED. LIMITATION OF LIABILITY: The remedies of purchaser set forth herein are exclusive, and the total liability of OMEGA with respect to this order, whether based on contract, warranty, negligence, indemnification, strict liability or otherwise, shall not exceed the purchase price of the component upon which liability is based. In no event shall OMEGA be liable for consequential, incidental or special damages.

CONDITIONS: Equipment sold by OMEGA is not intended to be used, nor shall it be used: (1) as a "Basic Component" under 10 CFR 21 (NRC), used in or with any nuclear installation or activity; or (2) in medical applications or used on humans. Should any Product(s) be used in or with any nuclear installation or activity, medical application, used on humans, or misused in any way, OMEGA assumes no responsibility as set forth in our basic WARRANTY/DISCLAIMER language, and, additionally, purchaser will indemnify OMEGA and hold OMEGA harmless from any liability or damage whatsoever arising out of the use of the Product(s) in such a manner.

## RETURN REQUESTS / INQUIRIES

Direct all warranty and repair requests/inquiries to the OMEGA Customer Service Department. BEFORE RETURNING ANY PRODUCT(S) TO OMEGA, PURCHASER MUST OBTAIN AN AUTHORIZED RETURN (AR) NUMBER FROM OMEGA'S CUSTOMER SERVICE DEPARTMENT (IN ORDER TO AVOID PROCESSING DELAYS). The assigned AR number should then be marked on the outside of the return package and on any correspondence.

The purchaser is responsible for shipping charges, freight, insurance and proper packaging to prevent breakage in transit.

FOR **WARRANTY** RETURNS, please have the following information available BEFORE contacting OMEGA:

1. Purchase Order number under which the product was PURCHASED,
2. Model and serial number of the product under warranty, and
3. Repair instructions and/or specific problems relative to the product.

FOR **NON-WARRANTY** REPAIRS, consult OMEGA for current repair charges. Have the following information available BEFORE contacting OMEGA:

1. Purchase Order number to cover the COST of the repair,
2. Model and serial number of the product, and
3. Repair instructions and/or specific problems relative to the product.

OMEGA's policy is to make running changes, not model changes, whenever an improvement is possible. This affords our customers the latest in technology and engineering.

OMEGA is a registered trademark of OMEGA ENGINEERING, INC.

© Copyright 2003 OMEGA ENGINEERING, INC. All rights reserved. This document may not be copied, photocopied, reproduced, translated, or reduced to any electronic medium or machine-readable form, in whole or in part, without the prior written consent of OMEGA ENGINEERING, INC.

# Where Do I Find Everything I Need for Process Measurement and Control? OMEGA...Of Course!

*Shop online at [www.omega.com](http://www.omega.com)*

## **TEMPERATURE**

- Thermocouple, RTD & Thermistor  
Probes, Connectors, Panels & Assemblies
- Wire: Thermocouple, RTD & Thermistor
- Calibrators & Ice Point References
- Recorders, Controllers & Process Monitors
- Infrared Pyrometers

## **PRESSURE, STRAIN AND FORCE**

- Transducers & Strain Gages
- Load Cells & Pressure Gages
- Displacement Transducers
- Instrumentation & Accessories

## **FLOW/LEVEL**

- Rotameters, Gas Mass Flowmeters  
& Flow Computers
- Air Velocity Indicators
- Turbine/Paddlewheel Systems
- Totalizers & Batch Controllers

## **pH/CONDUCTIVITY**

- pH Electrodes, Testers & Accessories
- Benchtop/Laboratory Meters
- Controllers, Calibrators, Simulators  
& Pumps
- Industrial pH & Conductivity Equipment

## **DATA ACQUISITION**

- Data Acquisition &  
Engineering Software
- Communications-Based  
Acquisition Systems
- Plug-in Cards for Apple, IBM  
& Compatibles
- Datalogging Systems
- Recorders, Printers & Plotters

## **HEATERS**

- Heating Cable
- Cartridge & Strip Heaters
- Immersion & Band Heaters
- Flexible Heaters
- Laboratory Heaters

## **ENVIRONMENTAL MONITORING AND CONTROL**

- Metering & Control Instrumentation
- Refractometers
- Pumps & Tubing
- Air, Soil & Water Monitors
- Industrial Water & Wastewater  
Treatment
- pH, Conductivity & Dissolved  
Oxygen Instruments

M0602/0496