

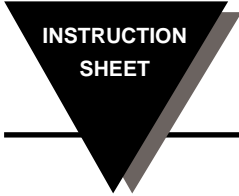

FL-W Series

Water Meter Monitors



M-0373/1206



INTRODUCTION

OMEGA's FL-W Series of Water Flow Monitors are rugged, variable-area flowmeters that can be used with flows from 1 gpm to 90 gpm. These flowmeters utilize the fluid movement to actuate either a swinging vane or piston, which drives the scale pointer and triggers the signal switch. Models FL-W01, FLW02, FLW05, FL-W10, FL-W15 and FL-W20 use the piston design. Models FL-W30, FL-W40, FL-W50, FL-W60, FL-W70, FL-W80 and FL-W90 use the swinging vane design.

SPECIFICATIONS

- ACCURACY:** \pm 5% full scale / piston models;
 \pm 2% full scale / vane models
- REPEATABILITY:** + 1% of reading
- TEMPERATURE RATING:** 200 °F max.
- PRESSURE RATING:** 150 psig max. (piston models);
300 psig max. (vane models)
- PRESSURE DROP:** 2-5 psi (piston models);
2.2 - 3.8 psi (vane models)
- SIGNALSWITCH:** 3-wire SPDT, 15A @ 125 VAC, CSA/CE rated
- INTERNAL WETTED PARTS:** 300 Series SS
- SEALS:** Buna and Teflon (piston models); Buna (vane models)

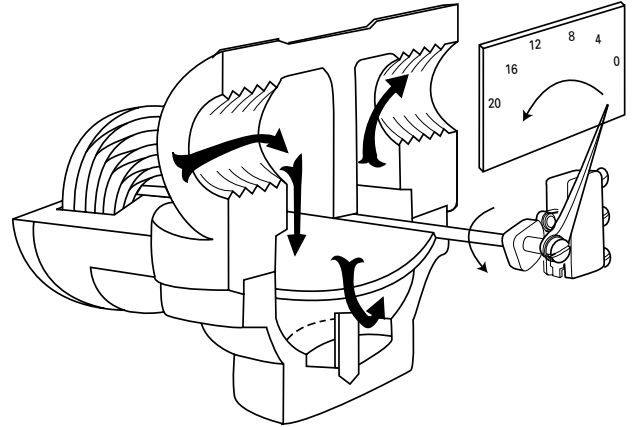

OPERATION DIAGRAM

INSTALLATION

This is an in-line device. To install, thread your piping into the NPT ports, with flow going into the port marked "IN". Mounting can be in any position. See dimension diagram.

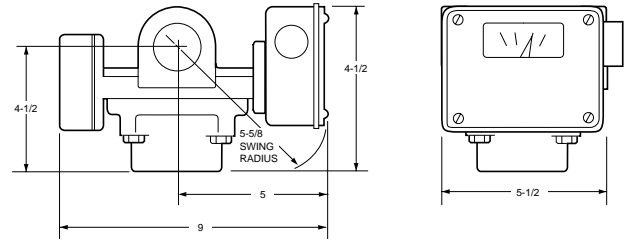

DIMENSION DIAGRAM

Model Number	Flow Rate GPM	Readout Increments	NPT Port Size	Design Type
FL-W01	0-1	0.2	3/4"	PISTON
FL-W02	0-2	0.25	3/4"	PISTON
FL-W05	0-5	1.0	3/4"	PISTON
FL-W10	0-10	2.0	3/4"	PISTON
FL-W15	0-15	3.0	3/4"	PISTON
FL-W20	0-20	4.0	3/4"	PISTON
FL-W30	0-30	5.0	1 1/2"	VANE
FL-W40	0-40	5.0	1 1/2"	VANE
FL-W50	0-50	10.0	1 1/2"	VANE
FL-W60	0-60	10.0	1 1/2"	VANE
FL-W70	0-70	10.0	2"	VANE
FL-W80	0-80	10.0	2"	VANE
FL-W90	0-90	10.0	2"	VANE

INSTRUCTIONS FOR MODELS FL-W30, FL-W40, FL-W50, FL-W60, FL-W70, FL-W80 and FL-W90

THEORY OF OPERATION

The FLW flow monitor utilizes the kinetic energy of a flowing liquid to move a spring-biased swinging vane. This action varies the orifice size in proportion to the flow rate. The vane is mechanically linked to a pointer which indicates the rate of flow on a scale. This mechanical output can also be used to trip electric switches.

RECOMMENDED INSTALLATION PRACTICES
Water hammer and surges can be damaging to any flowmeter and must always be avoided.
 Water hammer occurs when a liquid flow is suddenly stopped as with quick closing and solenoid operated valves. Surges occur when flow is suddenly begun, as when a pump is turned on at full power or a valve is quickly opened. Liquid surges are particularly damaging to flowmeters if the pipe is originally empty. To avoid damaging surges, fluid lines should remain full (if possible) and pumps should be brought up to power slowly and valves opened slowly. In addition, to avoid both water hammer and surges, a surge chamber should be installed.

CHANGING THE SPRING (VANE STYLE)

Remove the spring cover and the main spring. Place the new main spring onto the shaft and attach it by sliding the hole in the inside loop of the coil over the flat head rivet, and then place the outside loop over the roll pin with only 1/4 turn of the spring counter clockwise.

PERIODIC MAINTENANCE

Using a valve to vary the flow, observe the pointer tracking the flow rate. If the flow monitor does not respond properly, it is probably due to foreign material building up around the swinging vane and hanging it up. The vane can sometimes be jogged loose by manipulating the pointer. If it doesn't free up, remove the bowl and clean out the flow chamber around the swinging vane with a knife or brush.

For replacement parts, contact OMEGA Engineering Customer Service Department.

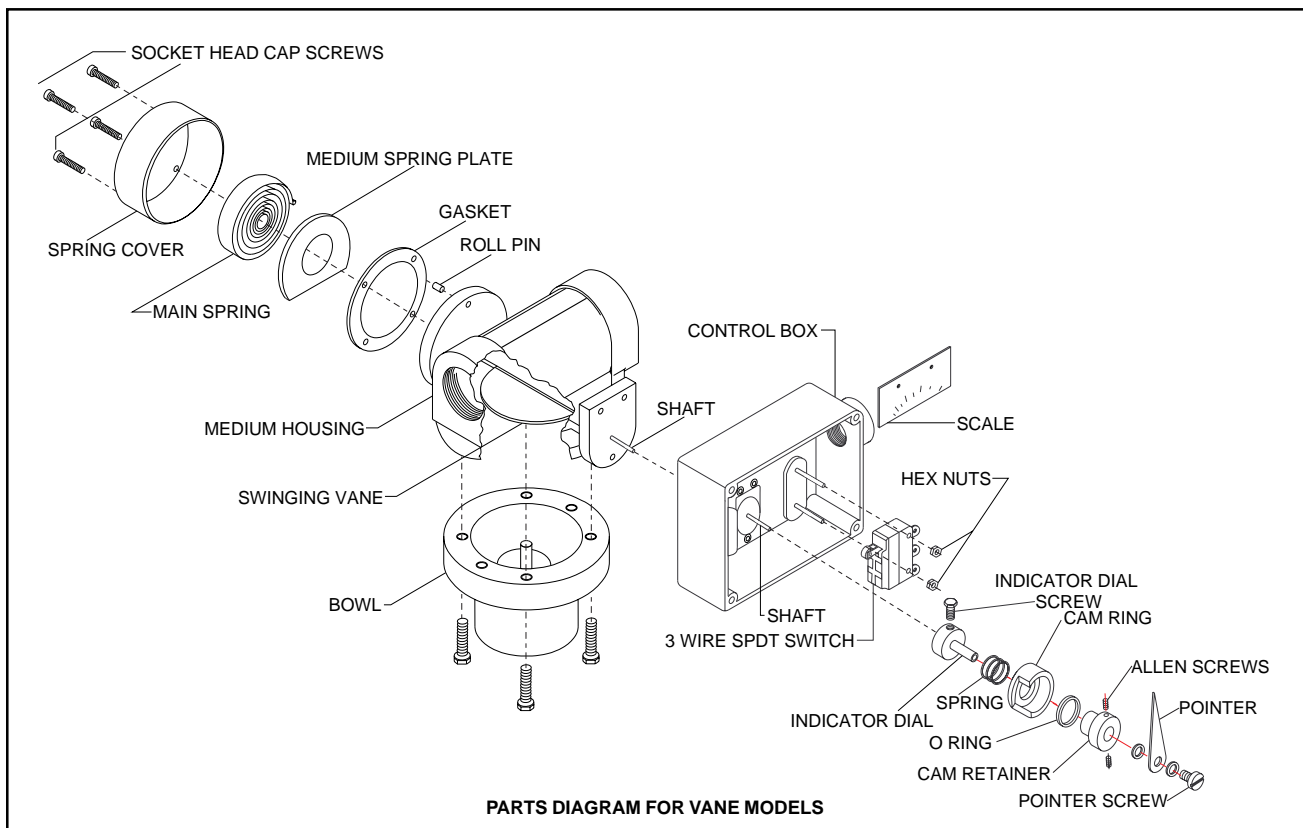

INSTRUCTIONS FOR MODELS FL-W01, FL-W02, FL-W05, FL-W10, FL-W15 and FL-W20

THEORY OF OPERATION

The FLW flow monitor utilizes the kinetic energy of a flowing liquid or gas to move a spring-biased piston. This action varies the orifice size in proportion to the flow rate. The piston is mechanically linked to a pointer which indicates the rate of flow on a scale. This mechanical output can also be used to trip electric switches.

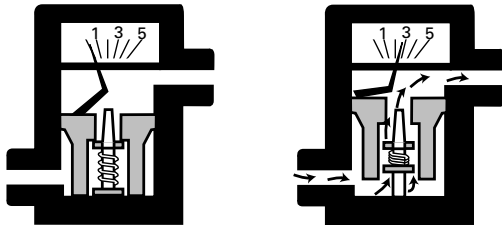

OPERATION DIAGRAM

INSTALLATION

This is an in-line device. To install, thread your piping into the NPT ports, with flow going into one of the two ports marked "IN". Mounting can be in any position. (See dimension diagram).

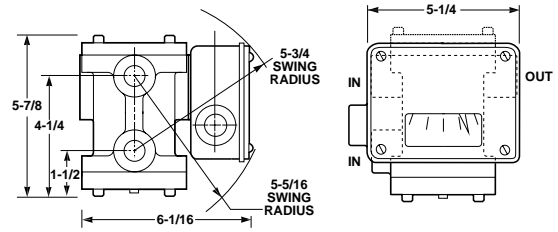

DIMENSION DIAGRAM

SERVICING FLOW SENSING MECHANISM

In the piston design, individual springs cannot be changed. All internal parts are contained in a replaceable capsule, including a piston, piston seal, and steel or stainless steel spring. The capsule is easily removed to correct a malfunction or to change the flow range, as follows:

Loosen the four cap screws from the lower end cap, and pull the end cap and attached flow sensing capsule out of the housing. The capsule may be cleaned by flushing in a liquid, or by a blast of compressed air. However, we do not recommend disassembly of the capsule.

Before installing a cleaned or replacement capsule, clean the interior of the housing with a rag or brush. The tell-tale arm that controls the motion of the pointer must be held out of the way while the capsule is installed. This is done by removing the face plate from the control box, and moving the pointer, by hand, in the direction of maximum scale reading while slipping the capsule and end cap into position. The pointer may then be released, the end cap tightened, and the face plate reinstalled.

For replacement parts, contact OMEGA Engineering Customer Service Department.

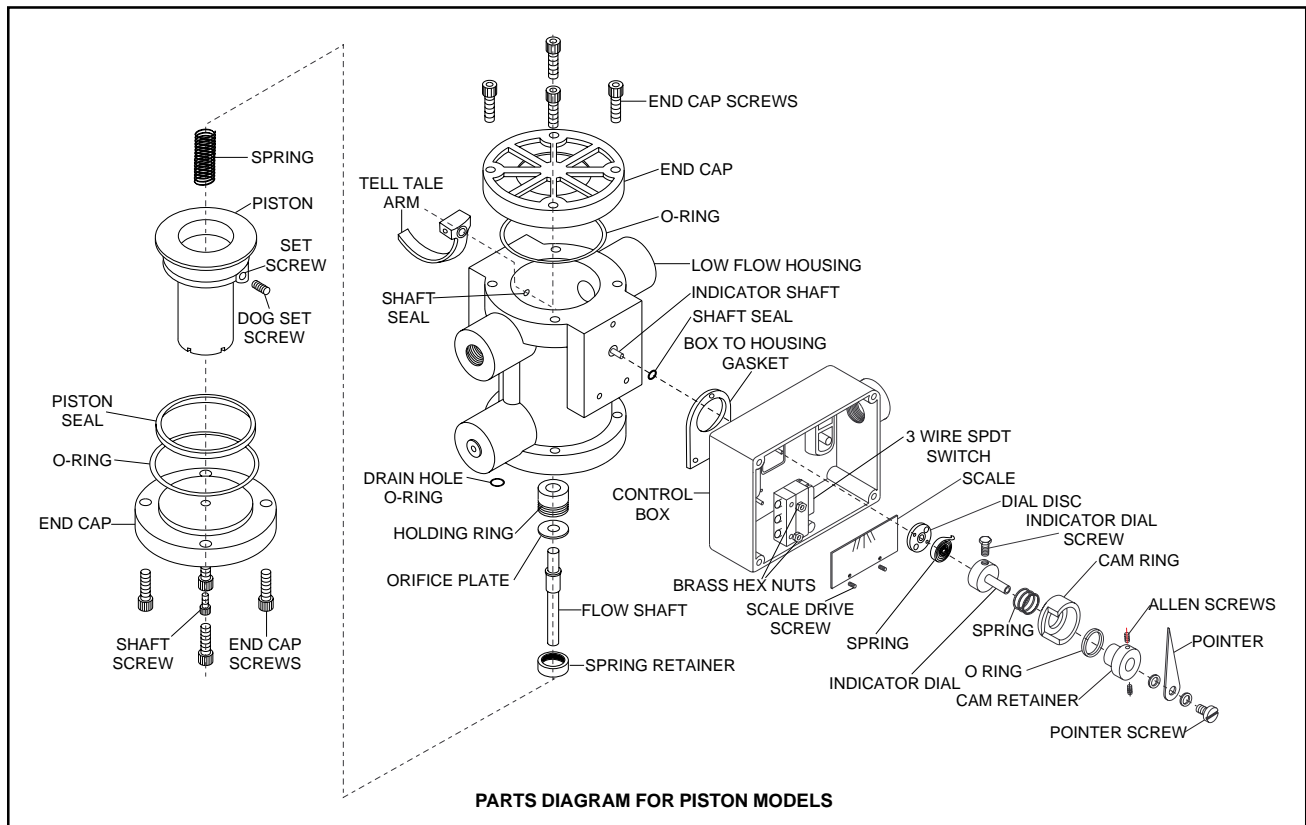

PARTS DIAGRAM FOR PISTON MODELS

CONNECTING THE SWITCH

To connect the switch, refer to the switch diagram.

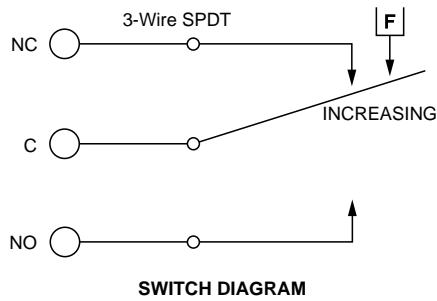

SETTING THE SWITCH POINT FOR VANE AND PISTON MODELS

The cam that actuates the switch is located on the dial assembly. The position of the cam dictates the switch point, i.e., the flow rate at which the cam throws the switch. (Usually, the switch point is initially set at OMEGA). To set or reset the switch point, proceed as follows:

Warning: Shut off the electric power to the control box before opening it.

1. Remove the nameplate, window, and gasket from the control box.
2. The cam that actuates the switch is located just under the pointer. The position of the cam dictates the flow rate at which the cam will trip the switch.
3. Turn the pointer so that it points at the desired flow rate on the scale. Against the low spring forces of the piston models you can do this by grasping the pointer itself (and holding it in position while you adjust the cam).

4. While holding the pointer in the desired position, depress the cam ring fully (approx. 1/16 inch) and rotate it until the switch actuates (clicks). Release your downward pressure and the cam ring will lock at that position.

5. If you can't hear the switch click, you can determine contact closure with an ohmmeter connected across the switch terminals. Connect to the common and normally open or normally closed on the switch.

6. To check the setting, direct the pointer again to the desired flow rate, noting where the switch actuates. Make adjustments as necessary. If the bowl was removed please place on guide roll pins and firmly tighten, in a X motion.

7. It's much easier to set the switch point if you can do it with actual flow present. Adjust the flow to the desired point where you want a signal to occur and turn the cam to actuate the switch as outlined above.

8. Replace window, nameplate, and gasket before turning on electric power.

Flow meters with very high spring force Vane models can be handled by *removing the bowl (under the housing).

WARNING: Isolate meter from process and be sure to bleed off any remaining pressure, as well as purge the line of any hazardous chemical prior to removing the bowl.

To maintain factory calibration accuracy, mark the bowl mounting orientation and replace the bowl in the same position after the cam is properly adjusted. The vane is then grasped and turned. To get the edge of the vane out of its recessed seat, use a socket head screw wrench as a lever, inserting it into one of the vane set screws to rotate the vane. To properly set the cam, the set point must be approached from the normal flow condition. I.E., a low flow contact is set for decreasing flow by moving the indicator above the low flow set point and adjusting the cam to activate or deactivate the switch just as it arrives at the low flow setting. To set the cam for an increasing set point, the cam is adjusted to activate/deactivate the switch as it approaches the set point from zero.



OMEGAnet™ On-Line Service
http://www.omega.com

Internet e-mail
info@omega.com

Servicing North America:

USA: One Omega Drive, Box 4047
ISO 9001 Certified Stamford, CT 06907-0047
Tel: (203) 359-1660 FAX: (203) 359-7700
e-mail: info@omega.com

Canada: 976 Bergar
Laval (Quebec) H7L 5A1
Tel: (514) 856-6928 FAX: (514) 856-6886
e-mail: canada@omega.com

For immediate technical or application assistance:

USA and Canada: Sales Service: 1-800-826-6342 / 1-800-TC-OMEGA™
Customer Service: 1-800-622-2378 / 1-800-622-BEST™
Engineering Service: 1-800-872-9436 / 1-800-USA-WHEN™
TELEX: 996404 EASYLINK: 62968934 CABLE: OMEGA

Mexico and Latin America: Tel: (95) 800-TC-OMEGA™ FAX: (95) 203-359-7807
En Español: (203) 359-1660 ext: 2203 e-mail: espanol@omega.com

Servicing Europe:

Benelux: Postbus 8034, 1180 LA Amstelveen, The Netherlands
Tel: (31) 20 6418405 FAX: (31) 20 6436463
Toll Free in Benelux: 06 0993344
e-mail: nl@omega.com

Czech Republic: Ostravska 767, 733 01 Karvina
Tel: 42 (69) 6311899 FAX: 42 (69) 6311114
e-mail: czech@omega.com

France: 9, rue Denis Papin, 78190 Trappes
Tel: 33 0130-621-400 FAX: 33 0130-699-120
Toll Free in France: 05-4-06342
e-mail: france@omega.com

Germany/Austria: Daimlerstrasse 26, D-75392 Deckenpfronn, Germany
Tel: 49 (07056) 3017 FAX: 49 (07056) 8540
Toll Free in Germany: 0130 11 21 66
e-mail: germany@omega.com

United Kingdom: 25 Swanington Road, P.O. Box 7, Omega Drive,
ISO 9002 Certified Broughton Astley, Leicestershire, Irlam, Manchester,
LE9 6TU, England M44 5EX, England
Tel: 44 (1455) 285520 Tel: 44 (161) 777-6611
FAX: 44 (1455) 283912 FAX: 44 (161) 777-6622
Toll Free in England: 0800-488-488
e-mail: uk@omega.com

It is the policy of OMEGA to comply with all worldwide safety and EMC/EMI regulations that apply. OMEGA is constantly pursuing certification of its products to the European New Approach Directives. OMEGA will add the CE mark to every appropriate device upon certification.

The information contained in this document is believed to be correct but OMEGA Engineering, Inc. accepts no liability for any errors it contains, and reserves the right to alter specifications without notice.
WARNING: These products are not designed for use in, and should not be used for, patient connected applications.



WARRANTY/DISCLAIMER

OMEGA ENGINEERING, INC. warrants this unit to be free of defects in materials and workmanship for a period of **13 months** from date of purchase. OMEGA Warranty adds an additional one (1) month grace period to the normal **one (1) year product warranty** to cover handling and shipping time. This ensures that OMEGA's customers receive maximum coverage on each product.

If the unit should malfunction, it must be returned to the factory for evaluation. OMEGA's Customer Service Department will issue an Authorized Return (AR) number immediately upon phone or written request. Upon examination by OMEGA, if the unit is found to be defective it will be repaired or replaced at no charge. OMEGA's WARRANTY does not apply to defects resulting from any action of the purchaser, including but not limited to mishandling, improper interfacing, operation outside of design limits, improper repair, or unauthorized modification. This WARRANTY is VOID if the unit shows evidence of having been tampered with or shows evidence of being damaged as a result of excessive corrosion; or current, heat, moisture or vibration; improper specification; misapplication; misuse or other operating conditions outside of OMEGA's control. Components which wear are not warranted, including but not limited to contact points, fuses, and triacs.

OMEGA is pleased to offer suggestions on the use of its various products. However, OMEGA neither assumes responsibility for any omissions or errors nor assumes liability for any damages that result from the use of its products in accordance with information provided by OMEGA, either verbal or written. OMEGA warrants only that the parts manufactured by it will be as specified and free of defects. OMEGA MAKES NO OTHER WARRANTIES OR REPRESENTATIONS OF ANY KIND WHATSOEVER, EXPRESSED OR IMPLIED, EXCEPT THAT OF TITLE, AND ALL IMPLIED WARRANTIES INCLUDING ANY WARRANTY OF MERCHANTABILITY AND FITNESS FOR A PARTICULAR PURPOSE ARE HEREBY DISCLAIMED. LIMITATION OF LIABILITY: The remedies of purchaser set forth herein are exclusive and the total liability of OMEGA with respect to this order, whether based on contract, warranty, negligence, indemnification, strict liability or otherwise, shall not exceed the purchase price of the component upon which liability is based. In no event shall OMEGA be liable for consequential, incidental or special damages.

CONDITIONS: Equipment sold by OMEGA is not intended to be used, nor shall it be used: (1) as a "Basic Component" under 10 CFR 21 (NRC), used in or with any nuclear installation or activity; or (2) in medical applications or used on humans. Should any Product(s) be used in or with any nuclear installation or activity, medical application, used on humans, or misused in any way, OMEGA assumes no responsibility as set forth in our basic WARRANTY/DISCLAIMER language, and additionally, purchaser will indemnify OMEGA and hold OMEGA harmless from any liability or damage whatsoever arising out of the use of the Product(s) in such a manner.

RETURN REQUESTS / INQUIRIES

Direct all warranty and repair requests/inquiries to the OMEGA Customer Service Department. BEFORE RETURNING ANY PRODUCT(S) TO OMEGA, PURCHASER MUST OBTAIN AN AUTHORIZED RETURN (AR) NUMBER FROM OMEGA'S CUSTOMER SERVICE DEPARTMENT (IN ORDER TO AVOID PROCESSING DELAYS). The assigned AR number should then be marked on the outside of the return package and on any correspondence.

The purchaser is responsible for shipping charges, freight, insurance and proper packaging to prevent breakage in transit.

FOR **WARRANTY** RETURNS, please have the following information available BEFORE contacting OMEGA:

1. P.O. number under which the product was PURCHASED,
2. Model and serial number of the product under warranty, and
3. Repair instructions and/or specific problems relative to the product.

FOR **NON-WARRANTY** REPAIRS, consult OMEGA for current repair charges. Have the following information available BEFORE contacting OMEGA:

1. P.O. number to cover the COST of the repair,
2. Model and serial number of product, and
3. Repair instructions and/or specific problems relative to the product.

OMEGA's policy is to make running changes, not model changes, whenever an improvement is possible. This affords our customers the latest in technology and engineering.

OMEGA is a registered trademark of OMEGA ENGINEERING, INC.

OMEGA is a registered trademark of OMEGA ENGINEERING, INC. All rights reserved. This document may not be copied, photocopied, reproduced, translated, or reduced to any electronic medium or machine-readable form, in whole or in part, without prior written consent of OMEGA ENGINEERING, INC.