

RoHS 2 Compliant



Thermocouple Process Monitor

User's Guide

Shop on line at

omega.com[®]

Ω OMEGA[®]

omega.com

e-mail: info@omega.com

For Latest Product Manuals

omegamanual.info

DP2000-K



OMEGAnet® On-Line Service omega.com	Internet e-mail info@omega.com
---	--

Servicing North America:

USA: One Omega Drive, P.O. Box 4047
ISO 9001 Certified Stamford CT 06907-0047
TEL: (203) 359-1660 FAX: (203) 359-7700
e-mail: info@omega.com

Canada: 976 Bergar
Laval (Quebec) H7L 5A1
TEL: (514) 856-6928 FAX: (514) 856-6886
e-mail: info@omega.ca

For immediate technical or application assistance:

USA and Canada: Sales Service: 1-800-826-6342 / 1-800-TC-OMEGA®
Customer Service: 1-800-622-2378 / 1-800-622-BEST®
Engineering Service: 1-800-872-9436 / 1-800-USA-WHEN®

Mexico and Latin American: TEL: (001) 203-359-7803 FAX: (001) 203-359-7807
e-mail: espanol@omega.com

Servicing Europe:

Benelux: Managed by the United Kingdom Office
TEL: +31 20 347 2121 FAX: +31 20 643 4643
Toll Free in Benelux: 0800 099 3344
e-mail: sales@omegaeng.nl

Czech Republic: Frystatska 184, 733 01 Karviná
TEL: +420 59 6311899 FAX: +420 59 6311114
e-mail: info@omegashop.cz

France: Managed by the United Kingdom Office
TEL: +33 1 61 37 29 00 FAX: +33 1 30 57 54 27
Toll Free in France: 0800 466 342
e-mail: sales@omega.fr

Germany/Austria: Daimlerstrasse 26, D-75392 Deckenpfronn, Germany
TEL: +49 7056 9398-0 FAX: +49 7056 9398-29
Toll Free in Germany: 0800 639 7678
e-mail: info@omega.de

United Kingdom: One Omega Drive
ISO 9001 Certified River Bend Technology Centre
Northbank, Irlam Manchester M44 5BD United Kingdom
TEL: +44 161 777 6611 FAX: +44 161 777 6622
Toll Free in England: 0800 488 488
e-mail: sales@omega.co.uk

It is the policy of OMEGA to comply with all worldwide safety and EMC/EMI regulations that apply. OMEGA is constantly pursuing certification of its products to the European New Approach Directives. OMEGA will add the CE mark to every appropriate device upon certification.

The information contained in this document is believed to be correct but OMEGA Engineering, Inc. accepts no liability for any errors it contains, and reserves the right to alter specifications without notice.

WARNING: These products are not designed for use in, and should not be used for, patient connected applications.



This device is marked with the international hazard symbol. It is important to read the Setup Guide before installing or commissioning this device as it contains important information relating to safety and EMC.

TABLE OF CONTENTS

SAFETY CONSIDERATIONS	ii
MAIN ASSEMBLY	
Specifications	1
Mechanical Assembly and Installation	4
Power & Signal Input Connections	5
Configuration Procedure	6
Configuration Charts	7
Tests and Diagnostics	9
Main Board Connector Pinouts (J1)	10
Drawings	11
SIGNAL CONDITIONER INPUT	
Specifications	16
Signal Input Connections	18
Tests and Diagnostics	19
Configuration Procedure	20
Configuration Charts	21
Calibration	22
Drawings	23
INSTALLATION INSTRUCTIONS	25

SAFETY CONSIDERATIONS



This device is marked with the international Caution symbol. It is important to read this manual before installing or commissioning this device as it contains important information relating to Safety and EMC (Electromagnetic Compatibility).

Unpacking & Inspection



Unpack the instrument and inspect for obvious shipping damage. Do not attempt to operate the unit if damage is found.

This instrument is a panel mount device protected in accordance with Class I of EN 61010 (115/230 AC power connections). Installation of this instrument should be done by Qualified personnel. In order to ensure safe operation, the following instructions should be followed.

This instrument has no power-on switch. An external switch or circuit-breaker shall be included in the building installation as a disconnecting device. It shall be marked to indicate this function, and it shall be in close proximity to the equipment within easy reach of the operator. The switch or circuit-breaker shall not interrupt the Protective Conductor (Earth wire), and it shall meet the relevant requirements of IEC 947-1 and IEC 947-3 (International Electrotechnical Commission). The switch shall not be incorporated in the mains supply cord.

Furthermore, to provide protection against excessive energy being drawn from the mains supply in case of a fault in the equipment, an overcurrent protection device shall be installed.



- The **Protective Conductor** must be connected for safety reasons. Check that the power cable has the proper Earth wire, and it is properly connected. It is not safe to operate this unit without the Protective Conductor Terminal connected.



- Do not exceed voltage rating on the label located on the top of the instrument housing.
- Always disconnect power before changing signal and power connections.
- Do not use this instrument on a work bench without its case for safety reasons.
- Do not operate this instrument in flammable or explosive atmospheres.
- Do not expose this instrument to rain or moisture.

EMC Considerations

- Whenever EMC is an issue, always use shielded cables.
- Never run signal and power wires in the same conduit.
- Use signal wire connections with twisted-pair cables.
- Install Ferrite Bead(s) on signal wires close to the instrument if EMC problems persist.

1.0 MAIN ASSEMBLY SPECIFICATIONS

1.1 GENERAL

OMEGAROMETER DP2000K main assemblies are identified by an initial designator (DP2) plus a power/display option numeral, zero thru nine (0-9).

The following table identifies the main assembly types:

Display Type	120 Vac	240 Vac	9-32 Vdc	5 Vac	24 Vac
LED	DP20	DP22	DP24	DP26	DP28
LCD	DP21	DP23	DP25	DP27	DP29

The OMEGAROMETER Process Monitor consists of a main assembly, signal conditioner and interface options (if ordered) all housed in a 1/8 DIN case.

The main assembly consists of a main board and a display board which is permanently attached to it at a 90 degree angle.

The main board provides mounting for the power supply, circuit components, and connectors for plugging in the signal conditioner, optional analog card, and optional controller/communications interface card (requires removal of a bypass push-on jumper).

The display board includes the analog-to-digital converter, the LED or LCD display and the push-on jumper for programming the decimal points. Decimal point programming may also be done from the main board connector (J1).

1.2 POWER

AC Models:	24/120/240V +10-15% 47-63 Hz
Common Mode Voltage:	1500 Vp test (354 Vp per IEC spacing)
DC Models:	5V \pm 5% (5V return common to signal LO) 9-32V (300V isolation from 9-32V return to signal LO)
Power Consumption:	5 watts maximum

1.3 DISPLAY

LED:	14.2mm (0.56 in), 7-segment light emitting diode
Lens Color:	Red
LCD:	12.7mm (0.50 in), 7-segment liquid crystal
Lens color:	Clear
Range:	0 to \pm 1999
Overload Indication:	Three least significant digits blanked, "1" or "-1" displayed

1.4 CONVERSION

Technique:	Auto-zero, dual slope, average value
Signal Integration Period:	100ms, nominal
Reading Rate:	2.5/second, nominal

1.5 ENVIRONMENTAL

Operating Temperature (Ambient):	0-60°C
Storage Temperature:	-40 to 85°C
Humidity:	To 95% RH, non-condensing, 0-40°C

1.6 MECHANICAL

Case Material:	UL-rated 94V-0, polycarbonate
Weight:	0.57 kg (with interface board)

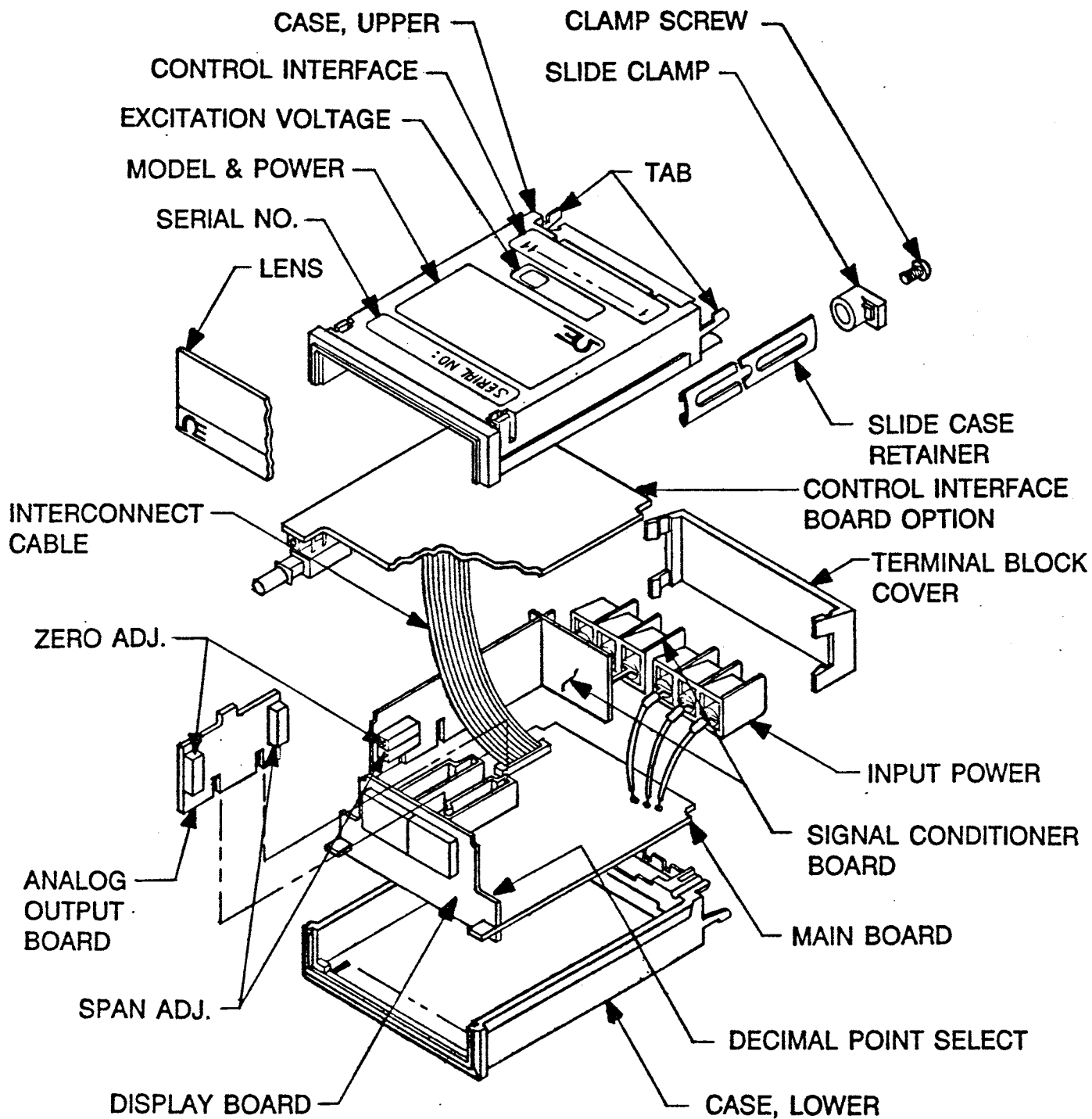

FIGURE 1 OMEGAROMETER EXPLODED VIEW

2.0 MECHANICAL ASSEMBLY & INSTALLATION

2.1 PANEL MOUNTING PROCEDURE (SEE FIGURE 1)

1. Remove the main board edge connector (J1), if installed.
2. Remove the interface board connector (J2), if installed.
3. Loosen two clamp screws on the rear of the case enough to rotate the two slide clamps.
4. Slide the two slide retainers toward the rear of the case and remove them.
5. From the front of the panel, insert the meter into the panel cutout.
6. Slide the slide retainers back onto the case and push up tightly against the rear of the panel.
7. Rotate the slide clamps back into their original position and tighten enough to hold the case in place. Overtightening can break the clamps.
8. Install any connectors removed.

2.2 LABELS (SEE FIGURE 2 FOR PLACEMENT)

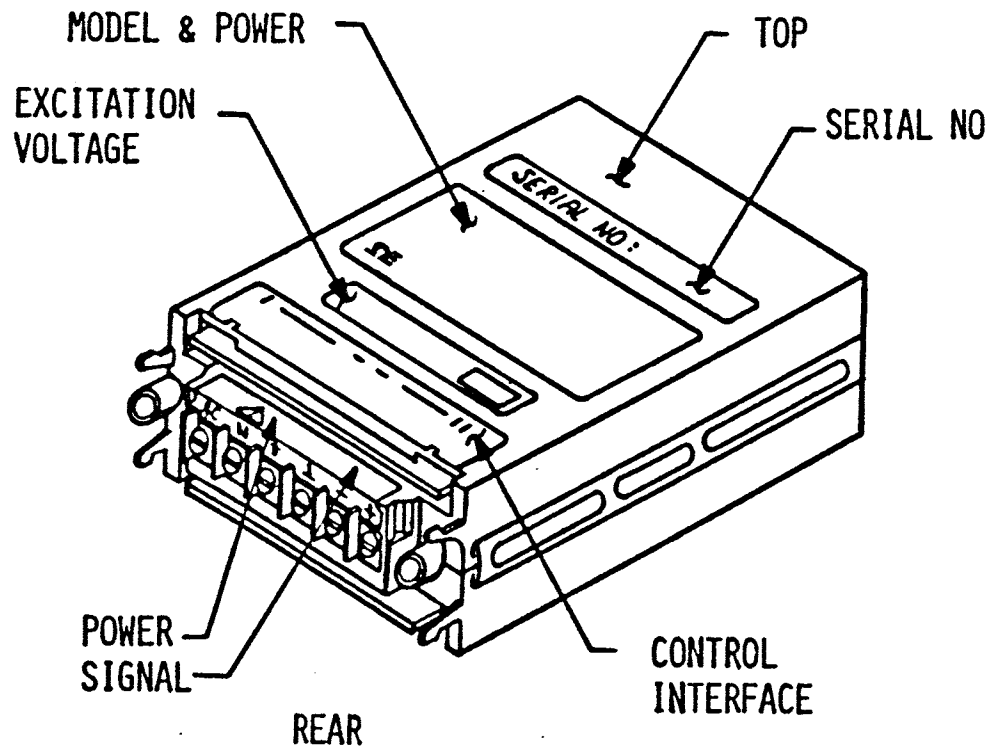

NOTE: READ LABELS FROM THE REAR

FIGURE 2. LABEL PLACEMENT

3.0 POWER & SIGNAL INPUT CONNECTIONS

WARNING: Incorrect power input can damage your OMEGAROMETER PROCESS MONITOR.

3.1 POWER CONNECTIONS

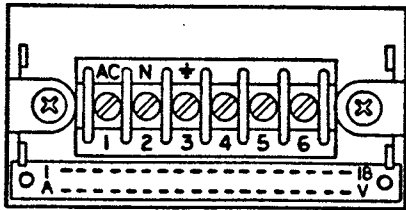

Terminal Connection	AC Versions	Wire Color
1	AC power HI	Black
2	AC power LO (neutral)	White
3	AC power GND	Green

REAR TERMINAL VIEW

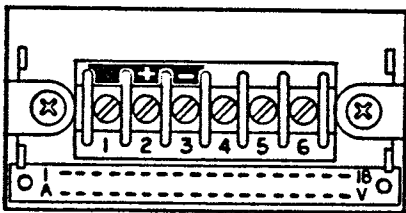

Terminal Connection	DC Versions
1	No connection
2	DC power +
3	DC power - (return)

3.2 SIGNAL INPUT CONNECTIONS

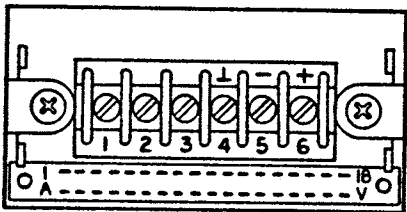

Terminal Connection	6 Terminal Versions Signal
4	Analog GND
5	- Signal LO
6	+ Signal HI

REAR TERMINAL VIEW

4.0 CONFIGURATION PROCEDURE

This procedure is used to set the decimal point of the display and interface board signal bypass selections for the configuration of the OMEGAROMETER DP2000X display and power options (DP20 through DP29).

The main assembly can be configured using the push-on jumpers provided or already positioned on the pin forests. Pin forest designations are shown at the top of every page of the configuration charts.

5.0 CONFIGURATION CHARTS
5.1 DECIMAL POINT SELECTION

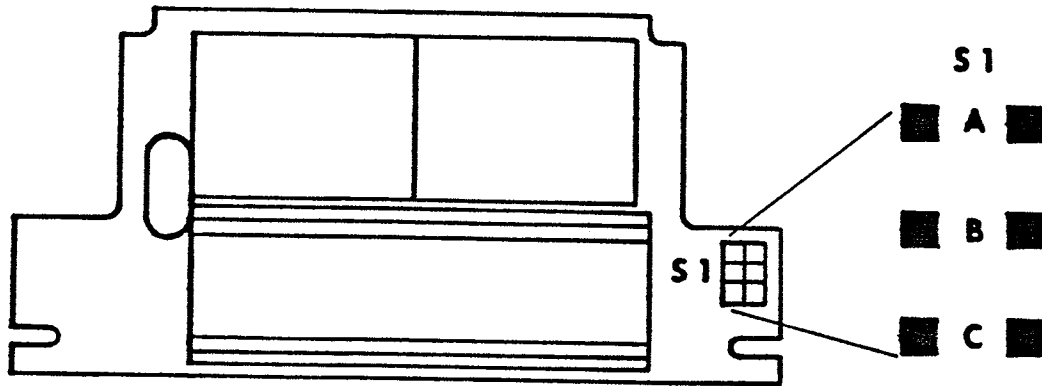

Step 1:		Remove all push-on jumpers not used in the desired configuration(s).
Step 2:		Select the desired configuration from the chart below, then install the push-on jumpers indicated.
Decimal Point Selection	S1	Alternate Decimal Point Selection Using Main Assembly Board (J1) Connector
Decimal Point (1.999)	A	Connect J1-K/9 to J1-6
Decimal Point (19.99)	B	Connect J1-J/8 to J1-6
Decimal Point (199.9)	C	Connect J1-H/7 to J1-6

5.2 INTERFACE BOARD SIGNAL BYPASS SELECTION

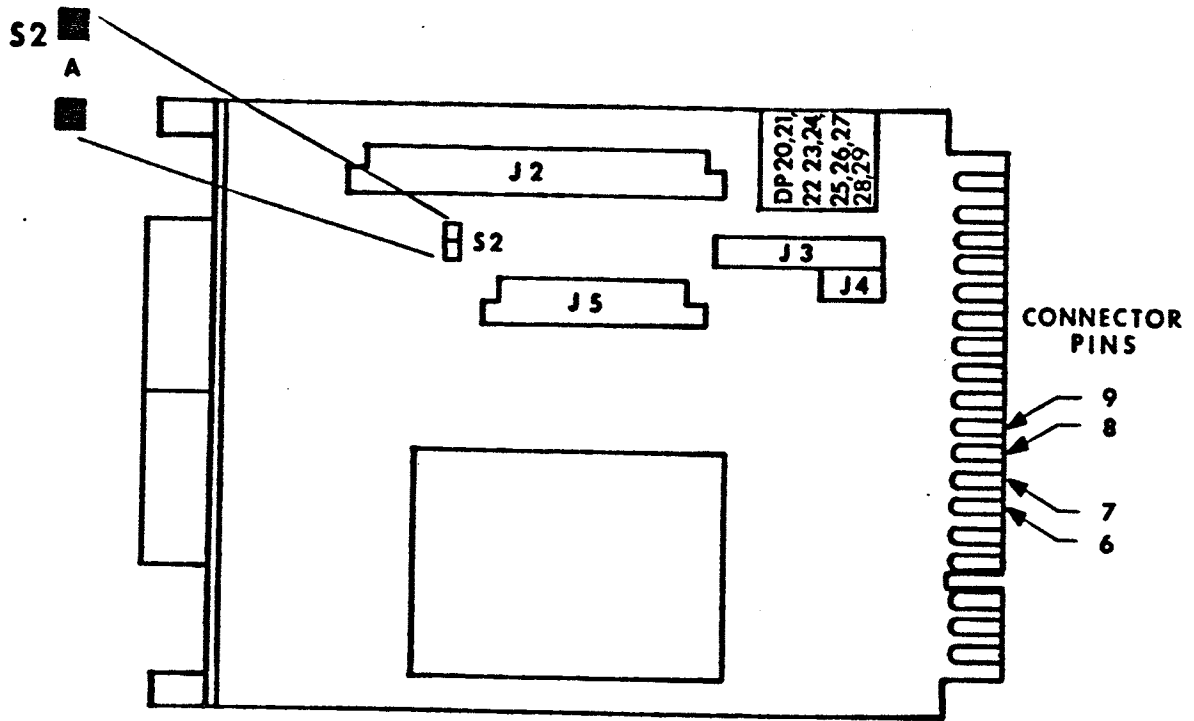

Step 1: Check your OMEGAROMETER part number for a zero (0) in the following position: DP2XX0X. If there is a zero (0) in that position, interface board signal bypass is required.	
Step 2: Remove all push-on jumpers not used in the desired configuration(s).	
Step 3: Select the desired configuration from the chart below, then install the push-on jumpers indicated.	
Interface Board Signal Configuration	S2
Interface Board Signal Bypass	A

6.0 TESTS & DIAGNOSTICS

6.1 TEST CONFIGURATION REQUIREMENTS

The OMEGAROMETER main assembly is designed to function with a signal conditioner board as a minimum configuration. There is no provision for testing a main assembly alone.

6.2 SIGNAL INPUT REQUIREMENTS

Signal input requirements for your configuration are identified in the signal conditioner section of this manual.

7.0 MAIN BOARD CONNECTOR PINOUTS (J1)

(Left to right, looking at rear of case)

<u>Connection</u>	<u>Function</u>	
A - 1	Spare	
B	Oscillator	40 kHz
2	-8.2 Vdc	Analog power
C - 3	Spare	
D	+ Pol (sign)	+ Polarity sign
4	Hold	LED version only
E - 5	Spare	
F	Buffer	Integrator output
6	Digital Ground	
H - 7	199.9 (Decimal Point)	Use with pin 6
J - 8	19.99 (Decimal Point)	Use with pin 6
K - 9	1.999 (Decimal Point)	Use with pin 6
L - 10	TEST (LED version only)	Use with pin M/11
M - 11	+5 Vdc	Analog & digital power
N - 12	Analog output	Standard 1 mV/count
P - 13	Spare	
R - 14	Spare	Used with H & S options - Excitation sense
S - 15	Analog Ground	
T - 16	Analog Option - Return	Used with analog option
U	Analog Option - Out	Used with analog option
17	+30 Vdc	Unregulated power
V - 18	Spare	Used with S option +Excitation sense

- Indicates common pin.
50 mA maximum power available from all internal sources.

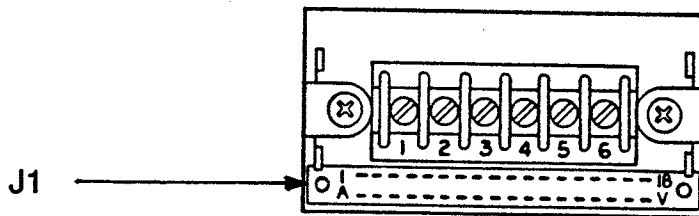

REAR TERMINAL VIEW

8.0 DRAWINGS

8.1 DIMENSIONS

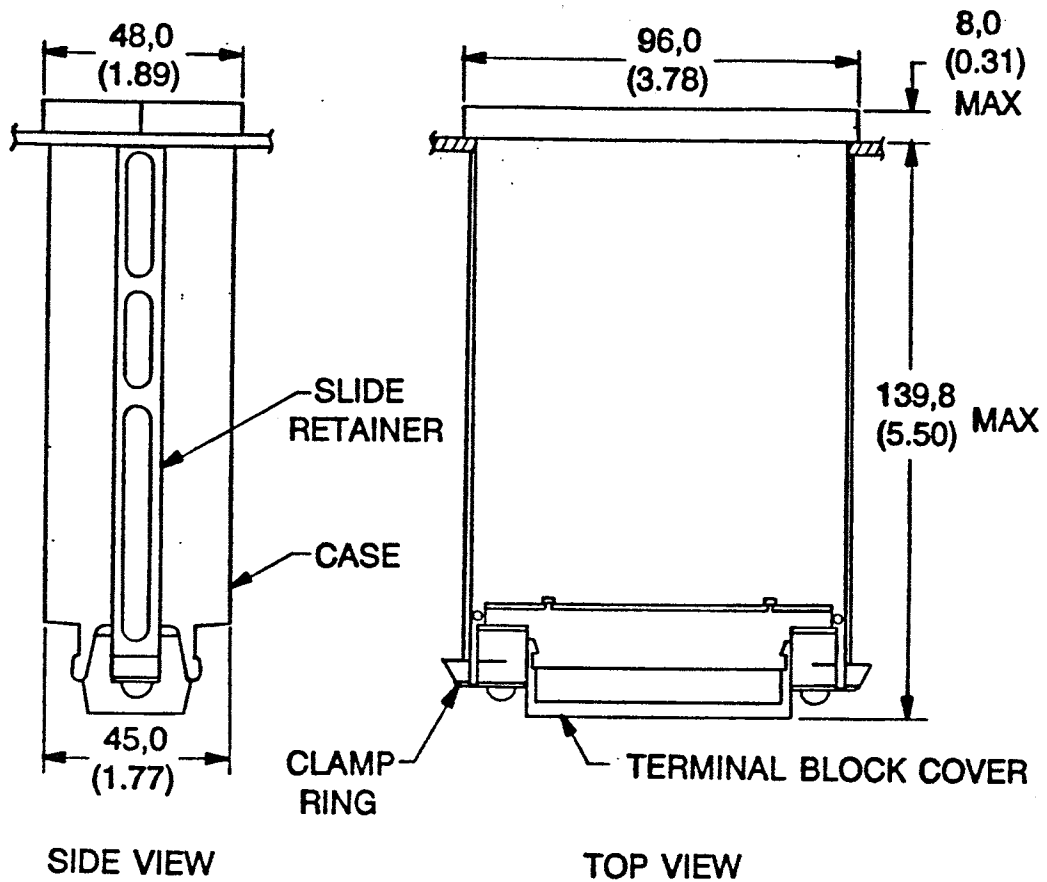

NOTE: Dimensions are in millimeters $\pm 0,25$ mm and inches are in () ± 0.01 in

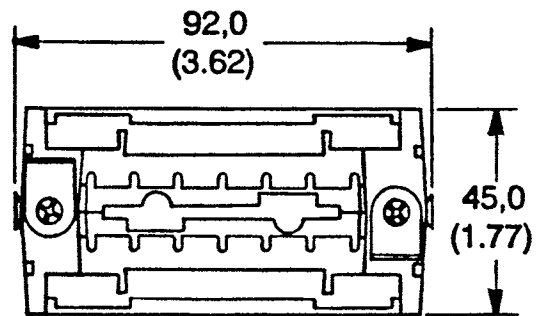
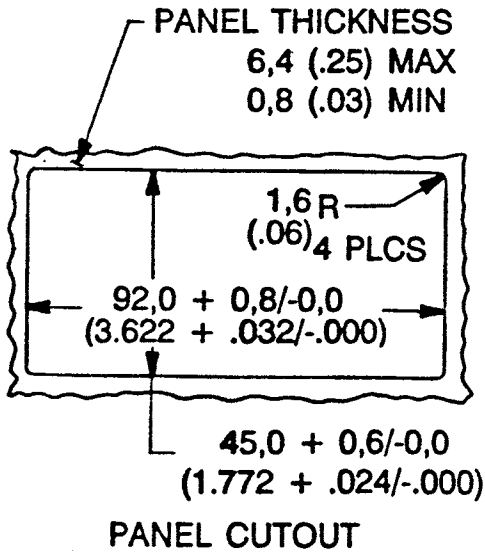

REAR VIEW
Terminal block cover and bezel not shown for clarity.
Clamp rings rotated and slide retainers removed as shown for installation.

8.2 DP2000 LED MAIN ASSEMBLY

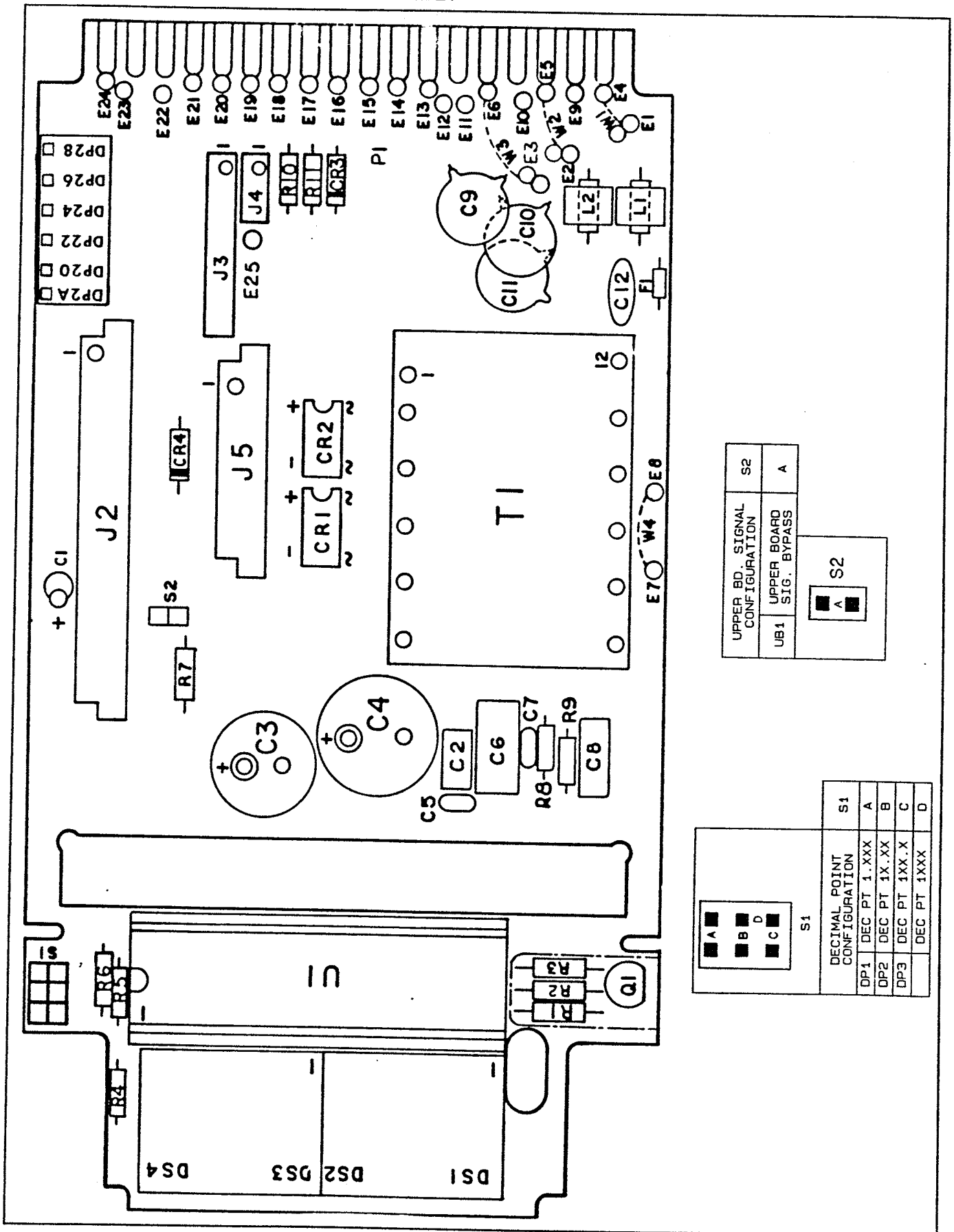

- DP28
- DP26
- DP24
- DP22
- DP20
- DP2A

UPPER BD. SIGNAL CONFIGURATION		S2
UB1	UPPER BOARD SIG. BYPASS	A

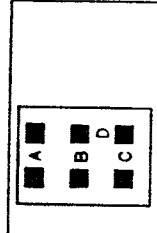
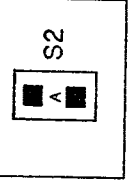

DECIMAL POINT CONFIGURATION		S1
DP1	DEC PT 1.XXX	A
DP2	DEC PT 1X.XX	B
DP3	DEC PT 1XX.X	C
	DEC PT 1XXX	D

8.3

THIS PAGE INTENTIONALLY LEFT BLANK

8.4 DP2000 LCD MAIN ASSEMBLY

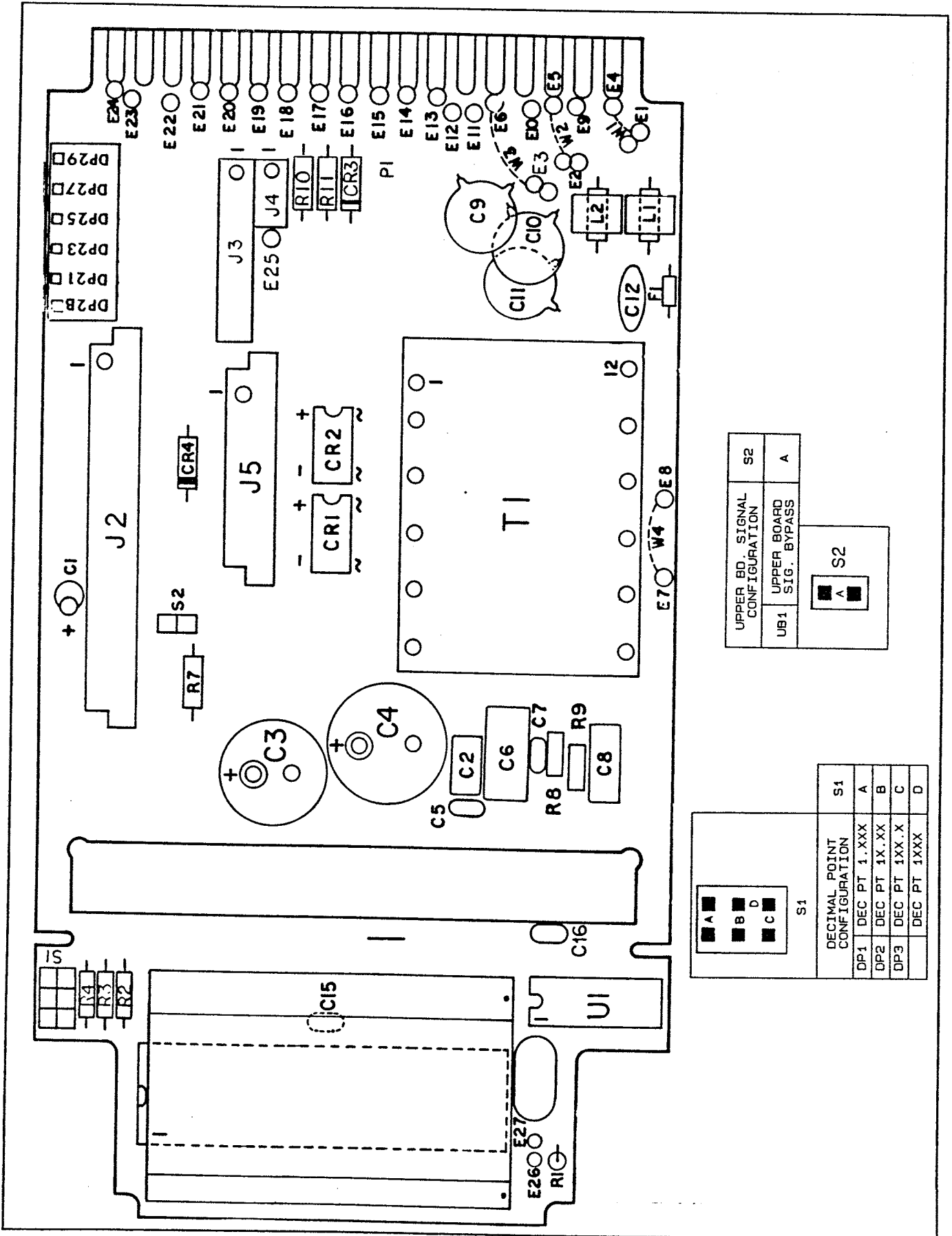

UPPER BD. SIGNAL CONFIGURATION		S2
UB1	UPPER BOARD SIG. BYPASS	A

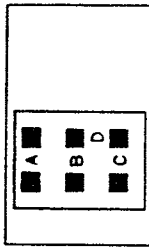
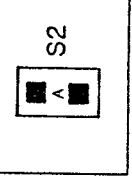

DECIMAL POINT CONFIGURATION		S1
DP1	DEC PT 1.XXX	A
DP2	DEC PT 1X.XX	B
DP3	DEC PT 1XX.X	C
	DEC PT 1XXX	D

8.5

THIS PAGE INTENTIONALLY LEFT BLANK

9.0 SPECIFICATIONS: BSCK, (DP2000K), TYPE K THERMOCOUPLE

9.1 GENERAL

The BSCK (DP2000K) will measure the temperature using an ANSI type "K" thermocouple.

The digital display can be scaled by internal push-on jumpers connectors and rezeroed for °C or °F.

The BSCK (DP2000K) has a high-accuracy temperature range of 0°C to 1260°C or 32°F to 1999°F. The BSCK (DP2000K) displays temperatures beyond this range (except beyond 1999), but the specified accuracy is not guaranteed for such readings.

9.2 TEMPERATURE SENSOR (CUSTOMER SUPPLIED)

Type	Thermocouple
Material Type K	Chromel-Alumel
Calibration	NBS (based on IPTS-68)
Lead Resistance, Max. Type K	395 Ohm

9.3 INPUT SIGNAL CONDITIONER

Configuration	Single-ended (+T/C lead connected to analog ground through 10 Ohm)
Polarity	Bipolar
Zero	Adjustable $\pm 5^{\circ}\text{C}$ ($\pm 10^{\circ}\text{F}$)
Overvoltage Protection (Differential)	120 V RMS (continuous) 240 V RMS (30 seconds maximum)
Sensor Break Detection	3 least-significant digits blanked
Sensor Break Detection Current	0.5 μA
NMR at 50/60 Hz	70 dB
Common Mode	
Analog ground to ac power ground	
CMR at dc to 60 Hz	120 dB
CMV at dc to 60 Hz	± 1500 Vp per high voltage test ± 354 Vp per IEC spacing
Linearization	POLYLOG III
Accuracy at 25°C °F or °C Scale Selection	By internal push-on jumpers
Reference Junction Tempco from 10°C to 40°C	± 0.08 degrees/degree
Span Tempco from 10°C to 40°C	0.01% R/°C
Warm-up to Rated Accuracy	Less than 15 minutes

MODEL	RANGE	OVERALL ERROR $\pm 1/2$ LSD	RESOLUTION
BCK °C (DP2000K)	0 TO 277°C +277 TO 1260°C	$\pm 1.8^\circ\text{C}$ $\pm 0.6\%$ R	1°C
BCK °F (DP2000K)	+32 TO 530°F 530 TO 1999°F	$\pm 3.0^\circ\text{F}$ $\pm 0.6\%$ R	1°F

10.0 SIGNAL INPUT CONNECTIONS (TB1)

10.1 The signal input connections for the BCK (DP2000K) Type K, Thermocouple signal conditioner are made at the standard 3-terminal barrier strip:

<u>Terminal Connection</u>	<u>Signal</u>	<u>Type K Thermocouple</u>
4	Analog ground	RED
5	-S Signal LO	
6	+S Signal HI	YELLOW

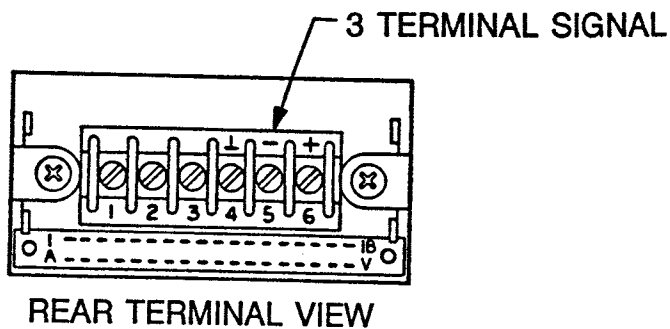

FIGURE 1. SIGNAL INPUT CONNECTIONS

11.0 TESTS AND DIAGNOSTICS

- The signal conditioner board BSCK (DP2000K) is designed to function with a main assembly as a minimum configuration. There is no provision for testing a signal conditioner board alone.
- Signal input requirements for your configuration are identified in the specifications for the BSCK (DP2000K) signal conditioner.
- Operating power and connections for your configuration are identified in the Main Assembly section of this manual.
- Inspect the OMEGAROMETER Process Monitor for physical damage. If damage is apparent, contact OMEGA Engineering at 1-800-622-2378. Save all packing materials.

FUNCTIONAL ELECTRICAL TESTING:

1. Short terminals 5 and 6 on barrier strip (TB1).
2. Apply proper power for your configuration to terminals 1, 2 and 3 on barrier strip (TB1).
3. Display will read approximately ambient room temperature.

12.0 CONFIGURATION PROCEDURE

12.1 GENERAL

This procedure is used to determine the configuration of the OMEGAROMETER DP2000K - thermocouple option (BSCK).

The unit can be configured using the push-on jumpers provided separately or already positioned on the pin forests. Pin forest designations are shown at the top of every page of configuration charts.

12.2 INSTALLATION

Select the degrees format required after calibration.

If a decimal point is required, refer to the Main Assembly Section DP20/DP29 for location and configuration procedure.

13.0 CONFIGURATION CHARTS

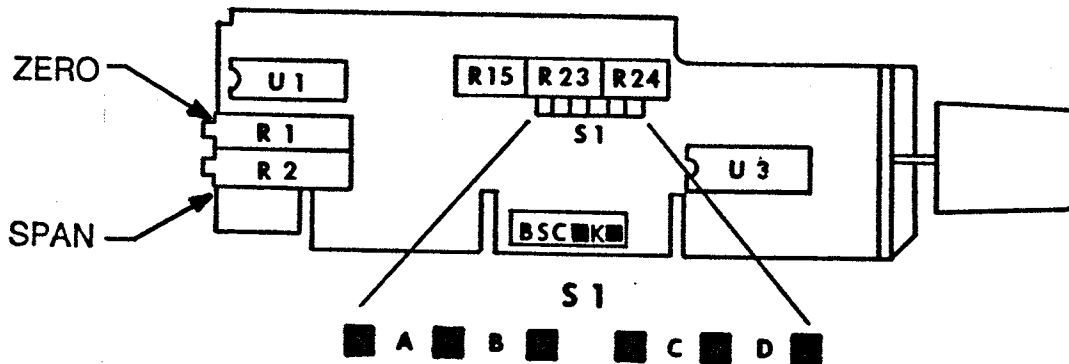

Step 1: Remove all push-on jumpers not used in the desired configuration(s).				
Step 2: Select the desired configuration from the chart below, then install the push-on jumpers indicated.				
	Degrees Configuration	S1		Used On
K1	Degrees "C"	A	C	DP2000K
K2	Degrees "F"	B	D	DP2000K

14.0 CALIBRATION

14.1 DEGREES CALIBRATION

For the following procedure, use a precision millivolts source connected as shown in the figure below. Alternately, a standard thermocouple calibrator can be used which does not require an ice bath for cold junction compensation. When using a thermocouple calibrator dial in the temperature required for each reading in the procedure.

NOTE: After calibration is completed the zero should be adjusted for each thermocouple used.

14.2 DEGREES "C" CALIBRATION

Install push-on jumpers S1-A, and S1-C per Section 13.0.

Apply an input of 0 V and adjust R1 (zero) for a reading of 000.

Apply an input of +48.83 mV and adjust R2 (span) for a reading of 1200.

14.3 DEGREES "F" CALIBRATION

To calibrate °F requires °C to be calibrated first see Section 14.2 then proceed as follows:

Remove and replace push-on jumpers S1-A and S1-C with push-on jumpers S1-B and S1-D per Section 13.0

Apply an input of 0 V and adjust R1 (zero) for a reading of 032.

Apply and input of +38.83 mV and adjust R24 for reading of 1720.

15.0 DRAWINGS
 15.1 BSCK ASSEMBLY DIAGRAM

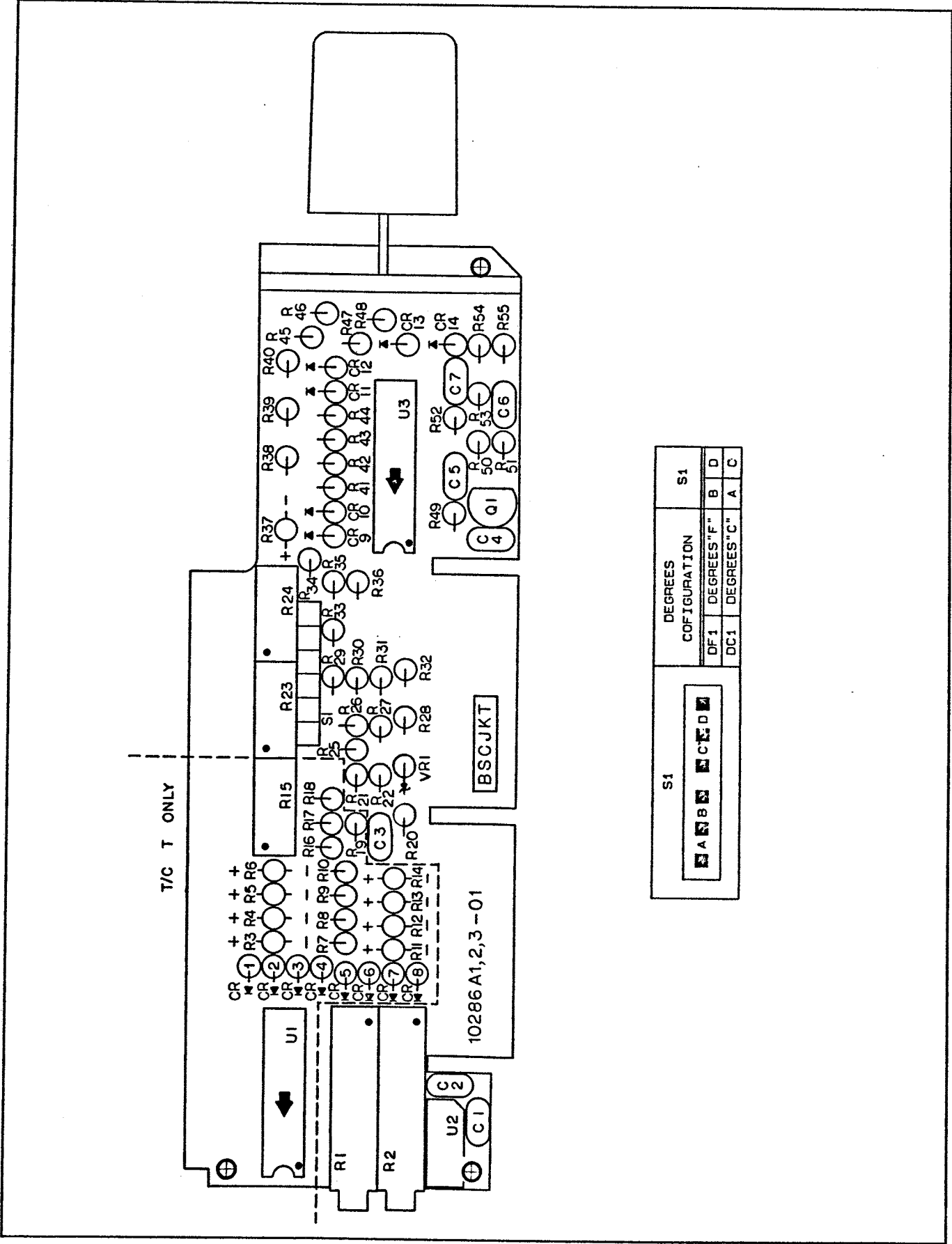

S1	DEGREES CONFIGURATION		S1
	DF1	DEGREES "F"	B D
	DC1	DEGREES "C"	A C

15.2

THIS PAGE INTENTIONALLY LEFT BLANK

16.0 DIGITAL PANEL METER INSTALLATION INSTRUCTIONS

IMPORTANT:

For proper installation electrical connections must be made according to the model number on the meter label. Write the model number in the following space and use the appropriate instructions for **your** model number.

..... Power requirement (Section 16.3)
.....
..... Analog output (see Analog Output Manual)
.....
..... Control output (see Control/Interface Manual)
.....
..... Signal input (Section 16.4)
.....

Model number DP2 _____

16.1 UNPACKING & INSPECTION

Your OMEGAROMETER PROCESS MONITOR meter was systematically inspected and tested, then carefully packed before shipment.

Unpack the instrument and inspect for obvious shipping damage. Notify the freight carrier immediately upon discovery of any shipping damage.

16.2 MECHANICAL INSTALLATION

1. Insure that the panel cutout dimensions are as shown on Figure 1.
2. Remove the lower printed circuit board edge connector, (if installed) J1, by pushing two molded plastic tabs away from the connector body and pulling the connector off the printed circuit board. Remove the printed circuit board edge connector, J2, if upper board output option was ordered.
3. Loosen two clamp screws on the rear of the case enough to rotate the two slide clamps.
4. Slide the two slide retainers toward the rear of the case and remove them.
5. From the front of the panel, insert the meter into the panel cutout.
6. Slide the slide retainers back onto the case and push up tightly against the rear of the panel.
7. Rotate the slide clamps back into their original position and tighten enough to hold the case in place. Overtightening can break the clamps.
8. Install the lower printed circuit board edge connector, if supplied, by pushing it on to the printed circuit board connections. Install the upper printed circuit board edge connector, if used.

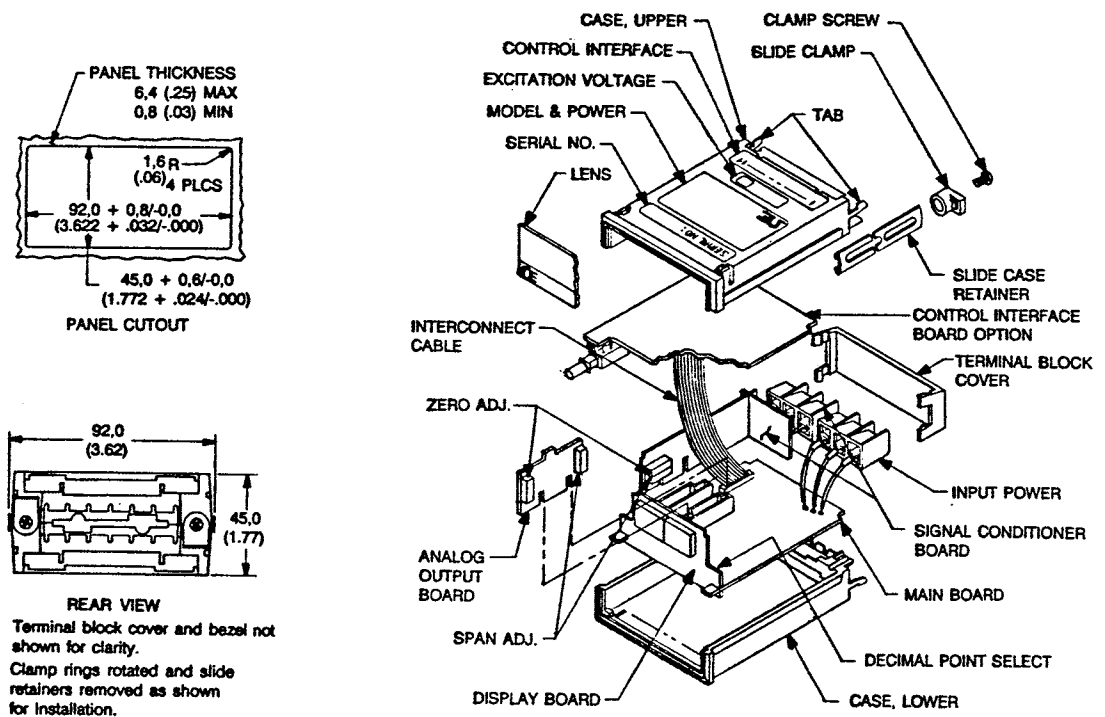

FIGURE 1. PANEL CUTOUT DIMENSIONS AND INSTALLATION

16.3 POWER REQUIREMENTS AND CONNECTIONS (TB1)

16.3.1 The standard meter is wired to operate from one of five power sources.

Models	Power Requirements
DP20XXX, DP21XXX,	120 Vac (50-60 Hz)
DP22XXX, DP23XXX,	240 Vac (50-60 Hz)
DP24XXX, DP25XXX,	9-32 Vdc
DP26XXX, DP27XXX,	5 Vdc
DP28XXX, DP29XXX,	24 Vac (50-60 Hz)

16.3.2 Regardless of the power source used, connections are made to the same terminal barrier strip, TB1, as follows:

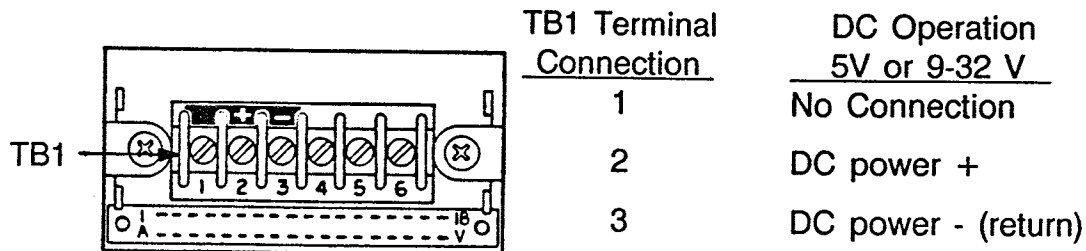
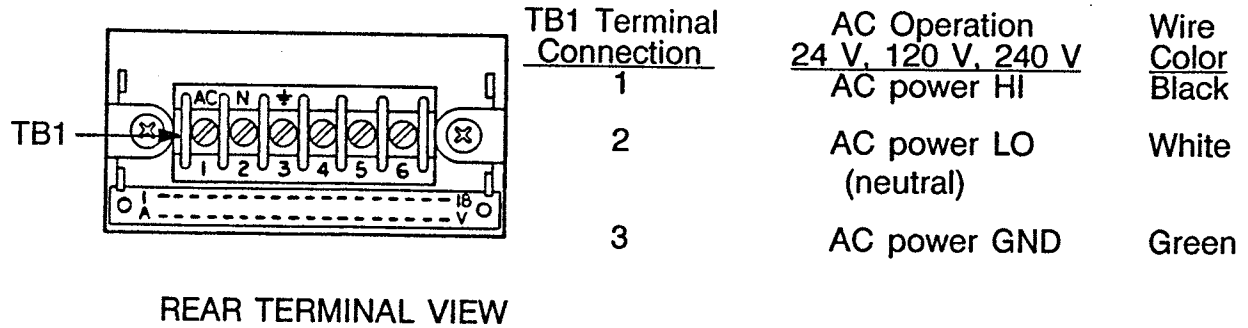

16.4 SIGNAL INPUT CONNECTIONS (TB1)

The signal input connections for the BSCK (DP2000K) Type K, Thermocouple signal conditioner are made at the standard 3-terminal barrier strip:

<u>Terminal Connection</u>	<u>Signal</u>	<u>Type K Thermocouple</u>
4	Analog ground	○ RED
5	-S Signal LO	○
6	+S Signal HI	○

YELLOW

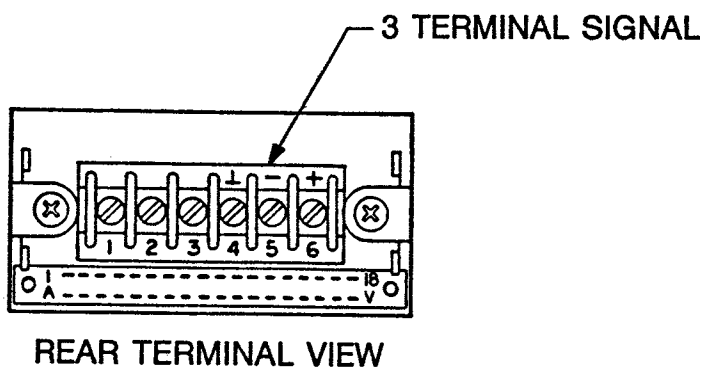

FIGURE 1. SIGNAL INPUT CONNECTIONS



WARRANTY/DISCLAIMER

OMEGA ENGINEERING, INC. warrants this unit to be free of defects in materials and workmanship for a period of **13 months** from date of purchase. OMEGA Warranty adds an additional one (1) month grace period to the normal **one (1) year product warranty** to cover handling and shipping time. This ensures that OMEGA's customers receive maximum coverage on each product.

If the unit should malfunction, it must be returned to the factory for evaluation. OMEGA's Customer Service Department will issue an Authorized Return (AR) number immediately upon phone or written request. Upon examination by OMEGA, if the unit is found to be defective it will be repaired or replaced at no charge. OMEGA's WARRANTY does not apply to defects resulting from any action of the purchaser, including but not limited to mishandling, improper interfacing, operation outside of design limits, improper repair, or unauthorized modification. This WARRANTY is VOID if the unit shows evidence of having been tampered with or shows evidence of being damaged as a result of excessive corrosion; or current, heat, moisture or vibration; improper specification; misapplication; misuse or other operating conditions outside of OMEGA's control. Components which wear are not warranted, including but not limited to contact points, fuses, and triacs.

OMEGA is pleased to offer suggestions on the use of its various products. However, OMEGA neither assumes responsibility for any omissions or errors nor assumes liability for any damages that result from the use of its products in accordance with information provided by OMEGA, either verbal or written. OMEGA warrants only that the parts manufactured by it will be as specified and free of defects. OMEGA MAKES NO OTHER WARRANTIES OR REPRESENTATIONS OF ANY KIND WHATSOEVER, EXPRESSED OR IMPLIED, EXCEPT THAT OF TITLE, AND ALL IMPLIED WARRANTIES INCLUDING ANY WARRANTY OF MERCHANTABILITY AND FITNESS FOR A PARTICULAR PURPOSE ARE HEREBY DISCLAIMED. LIMITATION OF LIABILITY: The remedies of purchaser set forth herein are exclusive and the total liability of OMEGA with respect to this order, whether based on contract, warranty, negligence, indemnification, strict liability or otherwise, shall not exceed the purchase price of the component upon which liability is based. In no event shall OMEGA be liable for consequential, incidental or special damages.

CONDITIONS: Equipment sold by OMEGA is not intended to be used, nor shall it be used: (1) as a "Basic Component" under 10 CFR 21 (NRC), used in or with any nuclear installation or activity; or (2) in medical applications or used on humans. Should any Product(s) be used in or with any nuclear installation or activity, medical application, used on humans, or misused in any way, OMEGA assumes no responsibility as set forth in our basic WARRANTY/DISCLAIMER language, and additionally, purchaser will indemnify OMEGA and hold OMEGA harmless from any liability or damage whatsoever arising out of the use of the Product(s) in such a manner.

RETURN REQUESTS / INQUIRIES

Direct all warranty and repair requests/inquiries to the OMEGA Customer Service Department. BEFORE RETURNING ANY PRODUCT(S) TO OMEGA, PURCHASER MUST OBTAIN AN AUTHORIZED RETURN (AR) NUMBER FROM OMEGA'S CUSTOMER SERVICE DEPARTMENT (IN ORDER TO AVOID PROCESSING DELAYS). The assigned AR number should then be marked on the outside of the return package and on any correspondence.

The purchaser is responsible for shipping charges, freight, insurance and proper packaging to prevent breakage in transit.

FOR **WARRANTY** RETURNS, please have the following information available BEFORE contacting OMEGA:

1. P.O. number under which the product was PURCHASED,
2. Model and serial number of the product under warranty, and
3. Repair instructions and/or specific problems relative to the product.

FOR **NON-WARRANTY** REPAIRS, consult OMEGA for current repair charges. Have the following information available BEFORE contacting OMEGA:

1. P.O. number to cover the COST of the repair,
2. Model and serial number of product, and
3. Repair instructions and/or specific problems relative to the product.

OMEGA's policy is to make running changes, not model changes, whenever an improvement is possible. This affords our customers the latest in technology and engineering.

OMEGA is a registered trademark of OMEGA ENGINEERING, INC.

© Copyright 2011 OMEGA ENGINEERING, INC. All rights reserved. This document may not be copied, photocopied, reproduced, translated, or reduced to any electronic medium or machine-readable form, in whole or in part, without prior written consent of OMEGA ENGINEERING, INC.

Where Do I Find Everything I Need for Process Measurement and Control? **OMEGA...Of Course!** *Shop on line at omega.com*

TEMPERATURE

- Thermocouple, RTD & Thermistor Probes, Connectors, Panels & Assemblies
- Wire: Thermocouple, RTD & Thermistor
- Calibrators & Ice Point References
- Recorders, Controllers & Process Monitors
- Infrared Pyrometers

PRESSURE, STRAIN AND FORCE

- Transducers & Strain Gauges
- Load Cells & Pressure Gauges
- Displacement Transducers
- Instrumentation & Accessories

FLOW/LEVEL

- Rotameters, Gas Mass Flowmeters & Flow Computers
- Air Velocity Indicators
- Turbine/Paddlewheel Systems
- Totalizers & Batch Controllers

pH/CONDUCTIVITY

- pH Electrodes, Testers & Accessories
- Benchtop/Laboratory Meters
- Controllers, Calibrators, Simulators & Pumps
- Industrial pH & Conductivity Equipment

DATA ACQUISITION

- Data Acquisition & Engineering Software
- Communications-Based Acquisition Systems
- Plug-in Cards for Apple, IBM & Compatibles
- Datalogging Systems
- Recorders, Printers & Plotters

HEATERS

- Heating Cable
- Cartridge & Strip Heaters
- Immersion & Band Heaters
- Flexible Heaters
- Laboratory Heaters

ENVIRONMENTAL MONITORING AND CONTROL

- Metering & Control Instrumentation
- Refractometers
- Pumps & Tubing
- Air, Soil & Water Monitors
- Industrial Water & Wastewater Treatment
- pH, Conductivity & Dissolved Oxygen Instruments