

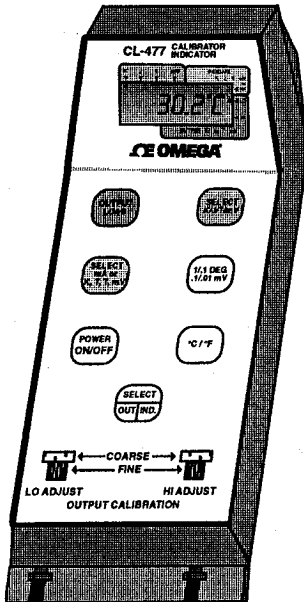

# CL-477

## Hand-Held Calibrator



### Operator's Manual



**Servicing USA and Canada: Call OMEGA Toll Free**

**USA**

One Omega Drive, Box 4047  
Stamford, CT 06907-0047 USA  
Telephone: (203) 359-1660  
FAX: (203) 359-7700

**Canada**

976 Bergar  
Laval (Quebec) H7L 5A1  
Telephone: (514) 856-6928  
FAX: (514) 856-6886

Sales Service: 1-800-826-6342 / 1-800-TC-OMEGA™  
Customer Service: 1-800-622-2378 / 1-800-622-BEST™  
Engineering Service: 1-800-872-9436 / 1-800-USA-WHEN™  
TELEX: 996404 EASYLINK: 62968934 CABLE OMEGA

**Servicing Europe: United Kingdom Sales and Distribution Center**

25 Swannington Road, Broughton Astley, Leicestershire  
LE9 6TU, England  
Telephone: 44 (0455) 285520 FAX: 44 (0455) 283912

**The OMEGA Complete Measurement and Control Handbooks & Encyclopedias**

- ✓ Temperature
- ✓ Pressure, Strain & Force
- ✓ Flow and Level
- ✓ pH and Conductivity
- ✓ Data Acquisition Systems
- ✓ Electric Heaters
- ✓ Environmental Monitoring and Control



**Call for Your FREE Handbook Request Form Today: (203) 359-RUSH**

266-4253-02C

# Table of Contents

<b>Section I</b>	<b>General Description .....</b>	<b>1</b>
	Unpacking and Inspection .....	2
	Repair or Warranty Service .....	4
<b>Section II</b>	<b>Operation .....</b>	<b>5</b>
	Introduction .....	5
	Keyboard Function Description .....	6
	Display Indicators .....	7
	Calibrator Output Controls .....	7
	mA Switch A/B .....	7
	Instrument Connections .....	8
	Calibrator Mode .....	9
	Transmitter Calibration .....	9
	Operational Guide, Calibrator Mode .....	10
	Indicator Mode .....	13
	Operation Guide, Indicator Mode .....	13
	Maintenance .....	14
	Battery Replacement .....	14
	Instrument Cleaning .....	15
<b>Section III</b>	<b>Calibration .....</b>	<b>17</b>
	Calibration Procedure .....	17
	Equipment Required .....	17
	mV Calibration .....	17
	Temperature Calibration .....	18
	mA Input Calibration .....	20
<b>Section IV</b>	<b>Theory of Operation .....</b>	<b>21</b>
	General .....	21
	DC mV Source .....	22
	Indicator Section .....	22
	Isolated mA Input .....	22
	Thermocouple/mV Input .....	23

<b>Section V</b>	<b>Specifications .....</b>	<b>25</b>
	Functional .....	25
	Input Impedance	
	(Indicator Mode):.....	25
	Range/Span/Resolution	
	(Input/Output).....	25
	Performance .....	26
	Noise Rejection .....	26
	Accuracy at 72 °F.....	26
	Stability With Time .....	26
	Stability With Temperature.....	26
	Physical/Environment .....	26
	<b>Schematic Diagrams/Assembly Drawing .....</b>	<b>29</b>
	<b>Assembly Parts List .....</b>	<b>37</b>

The hand-held, battery operated, Thermocouple Calibrator/Indicator is used for calibration (output) or indication (input) of thermocouple or DC voltage devices. The instrument also functions as an isolated milliammeter for measuring the output from a current transmitter. The following ranges are provided:

- Thermocouple, NBS Type J
- Thermocouple, NBS Type K
- Thermocouple, NBS Type T
- mV
- mA (input only)

This truly portable, rugged, and accurate instrument features intrinsically safe design for operation in hazardous environments.

Calibration of transmitter using types K, J, or T thermocouple inputs is easily accomplished by the Thermocouple Calibrator/Indicator. A principal feature of the instrument is the capability to output the LO or HI calibration value while simultaneously measuring current with the isolated milliammeter. This feature in a hand-held instrument provides an ideal means of calibrating isolated and non-isolated transmitters anywhere in the field. The instrument is also switch selectable to accept voltage input from transmitters with a 40-200 mV calibration output.

The instrument is controlled from a seven function keyboard in conjunction with dual Coarse and Fine calibrator output adjust controls. For ease of operation, the keyboard is conveniently color keyed by function, corresponding by color to the appropriate display legend and the input/output jack overlay. Input or output measurements are shown on an easy-to-read, 3 3/4-digit liquid crystal display (LCD). Display resolution is keyboard selectable for 1° or 0.1° reading for thermocouple ranges and 0.1mV or 0.01mV reading for the millivolt range. Resolution of the milliamp range is fixed at 0.01 mA. Temperature measurements are keyboard selectable for °C or °F readings. The calibrator output is keyboard selectable for high or low range output.

A sub-miniature thermocouple connector and a pair of sub-miniature banana jacks at the back of the instrument provide quick connection of input/output leads. The instrument is powered by an easily replaceable 9-volt transistor radio battery.

The compact Thermocouple Calibrator/Indicator is housed in a textured, high impact ABS plastic case. Overall dimensions are 2.75 in (7 cm) H x 3.75 in (9.5 cm) W x 8.35 in (21.2 cm) L. Weight is approximately 16 ounces (454 grams).

## **Unpacking and Inspection**

Before placing the Thermocouple Calibrator/Indicator in service, inspect the instrument for possible shipping damage, inventory contents for correct accessories and options, and check the instrument for proper operation. Promptly report physical damage, missing items, or improper operation to the factory.

The following is provided as standard with each Thermocouple Calibrator/Indicator unit:

- 9V transistor radio battery
- Carrying case with shoulder strap
- One pair, coil cord copper-copper mV test leads (T/C plug)
- One pair, coil cord mA input test leads (mini-banana plugs)
- Two alligator clip lead adapters
- Two mini-to-standard banana plug adapters
- Thermocouple Table
- Operator's Manual

After inspection, use the following procedure to verify that the instrument is operating properly. This test can be used whenever a quick check of instrument operation is needed (see Figure 1 and refer to pages 6 and 7 for the descriptions of control functions):

- Step 1:** With no connection to inputs, turn instrument ON by pressing **POWER ON/OFF** key. Observe that the display is active and may come up in either indicator or HI or LO calibrator mode.
- Step 2:** Depending on which output is active (HI or LO) turn appropriate **COARSE OUTPUT ADJUST** control full clockwise; then counterclockwise. Observe that displayed value increments and decrements accordingly. This shows that calibrator source is functional. Note that thermocouple ranges will show over-range display (three columns of dashes) at adjustment extremes. Press the **OUTPUT LO/HI** key and test the alternate **COARSE OUTPUT ADJUST** control as described above.
- Step 3:** Place instrument in indicator mode by pressing **SELECT INDICATE/OUTPUT** key. Verify that neither HI or LO output is shown on display.
- Step 4:** Press **SELECT K, J, T, mV** key once for each type input shown on upper portion of display (K, J, T, and mV). Verify that display range indication changes with each actuation of **SELECT K, J, T, mV** key and that three columns of dashes are shown for each range selected.
- Step 5:** Insert test leads in T/C jack and short ends of leads together.
- Step 6:** Press **SELECT K, J, T, mV** key once for each type input shown on upper portion of display (K, J, T, and mV). Verify that display shows approximate ambient temperature for thermocouple ranges and 0.0mV for mV range.
- Step 7:** Remove test leads and turn instrument OFF.

## **Repair or Warranty Service**

When returning the instrument for repair or warranty service, please enclose a letter of transmittal. The following information in the letter will expedite service:

- Model and serial number of instrument
- Description of problem and circumstances of failure
- Request warranty service if appropriate (refer to original shipping date)
- Name and telephone number of person responsible for returning the instrument
- Billing address
- Shipping address



## Introduction

See Figures 1 and 2 for locations of all controls, connectors, and indicators described in the following paragraphs.

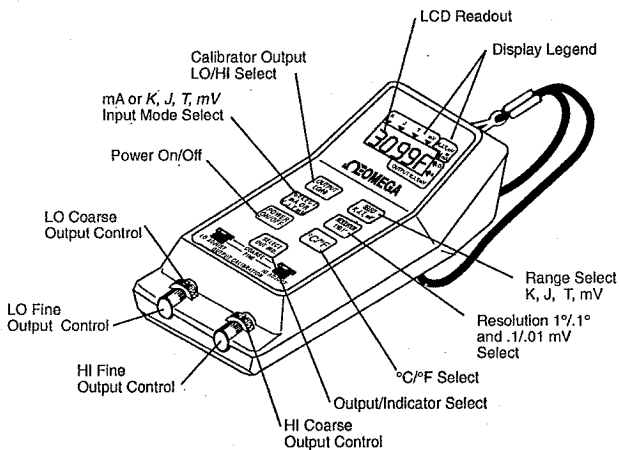

*Figure 1. Calibrator/Indicator Unit*

## Keyboard Function Description

**POWER ON/OFF key:** Controls power to instrument. Press once for ON. Press again for OFF. Instrument can be in either indicator or calibrator mode when first turned on.

**SELECT INDICATE/OUTPUT key:** Selects indicator or calibrator mode for thermocouple or millivolt ranges. To switch modes, press the **SELECT INDICATE/OUTPUT key**. The calibrator mode is indicated on the display by a HI or LO range output indication (refer to **OUTPUT LO/HI key** description below). The indicator mode is indicated on the display by the absence of a HI or LO range output indication.

**SELECT K, J, T, mV key:** Selects the type of input the instrument will measure or calibrate. The type of input selected is shown on the LCD readout as a dot under the appropriate portion of the display legend (K, J, T, or mV). Each time the **SELECT K, J, T, mV key** is pressed, the display indication steps to the next range in sequence, left to right and back again to "K".

**°C/°F key:** Selects Celsius or Fahrenheit readout for thermocouple ranges. The LCD readout shows the temperature scale selected as °C or °F. To change from one scale to the other, press the **°C/°F key** as required. This key is inoperative for the mV and mA ranges.

**RESOLUTION 1°/0.1° key:** Selects 1° or 0.1° display resolution for thermocouple ranges and 0.1mV or 0.01mV display resolution for the millivolt range. This key is inoperative in the mA input mode. To change from one display resolution to the other, press the **RESOLUTION 1°/0.1° key** as required. When the instrument is in the high resolution mode (0.1° or 0.01 mV), an auto-ranging feature is in effect. When the limit (either positive or negative) has been reached for the high resolution range, the instrument will automatically switch to the low resolution mode (1° or 0.1mV) and continue reading up to the absolute limit of that range. Thus, an over-range input or output is always show on the lower resolution of that range. Note that the Thermocouple Calibrator/Indicator will not automatically switch back from low to high resolution display when the input/output returns to within the high resolution range of the instrument.

**OUTPUT LO/HI key:** Selects which of two calibrator output ranges (LO or HI) to appear at the T/C input/output jack. The calibrator output range selected is shown on the LCD as a dot to the left of the appropriate portion of the display legend (LO or HI). Each time the **OUTPUT LO/HI key** is pressed, the instrument switches to the other calibrator output range.

**mA INPUT key:** Places instrument in mA current measuring mode. Press this key once and the instrument displays the input from the mA input terminals; outputs from the instrument remain unaffected. Press this key again and the instrument displays the last range selected by the **SELECT K, J, T, mV key**. The mA input mode is shown on the LCD by a dot to the left of the mA display legend. Also refer to Transmitter Calibration on pages 9 and 10.

### Display Indicators

The LCD readout has indicators for low battery, over-range/open thermocouple input, °C/°F temperature scale, and negative polarity. The display also has indicators for range/function select (mV, mA, K, J, and T) and calibrator HI/LO output. These are shown as a dot next to the appropriate portion of the display legend.

### Calibrator Output Controls

Each calibrator output range (LO and HI) is controlled individually by 10-turn Coarse and Fine output controls. The Coarse control provides a coarse adjustment of the calibrator output to within the range of the Fine control. The Fine control provides a fine adjustment of the calibrator input to within 0.1° or 0.01 mV depending on range used. Refer to Calibrator Mode on page 9.

### mA Switch A/B

A slide switch, located inside the battery compartment, selects the operating mode of the mA Input function. Refer to Transmitter Calibration on pages 9 and 10.

### Instrument Connections

Input/Output connections are made at the back of the instrument (see Figure 2). The connector used for thermocouple/millivolt

connections is polarized. The mA banana jacks are color-coded and labeled as follows:

RED high/positive (+), BLACK low/negative (-).

If thermocouple wire is being used for the interconnection, a mating sub-miniature thermocouple connector (male type SMP or equivalent) must be used to ensure accurate readings. The connector shell is color coded by type: Type K, yellow; Type J, black; Type T, blue; uncompensated Copper-Copper, white.

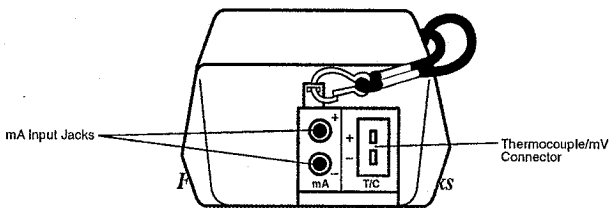

Connections for the mV range use the test leads terminated with an uncompensated (Copper-Copper) T/C connector on one end. Connections for T/C ranges must use interconnecting thermocouple wire of the appropriate type. A thermocouple leadset kit is available as an option for this purpose. The kit includes one each, coil cord test leads for Types K, J, and T thermocouples (60 inches/152.4 cm fully extended). These test leads are terminated with the appropriate Omega SMP male thermocouple connector on one end and spade lugs on the other end.

Connections to the mA input use the test leads terminated in mini-banna plugs on both ends. The banana plug adapters (alligator and mini-to-standard) allow connection of the mA input leads to various applications.

### **Note**

Avoid low impedance connections (such as a thermocouple probe) to the T/C jack until the instrument is turned on and the indicator mode selected.

## **Calibrator Mode**

The instrument provides two calibrator output ranges which are alternately available from the instrument. The calibrator outputs, designated LO and HI, are controlled individually by 10-turn Coarse and Fine controls as described in the Calibrator Output Controls section on page 7. The output controls are located at the front of the instrument. The left Output Adjust controls adjust the calibrator LO output. The right Output Adjust controls adjust the calibrator HI output. Both LO and HI outputs can be adjusted over the entire temperature and millivolt range. If the output is adjusted beyond that of the range selected, an over-range condition of three columns of dashes replacing the digit data is shown on the display (same indication as a break detect).

A typical application for the LO and HI calibrator outputs is to set the calibrator LO output for the minimum or negative full-scale value and the calibrator HI output for the maximum or positive full-scale value of the range being output. The two outputs can then be switched back and forth for easier adjustment of the instrument being calibrated.

### **Transmitter Calibration**

When calibrating transmitters, the instrument is in the calibrator mode supplying the input signal while simultaneously measuring the current output from the transmitter.

Press the **mA INPUT** key to measure the input at the mA input jacks. The output from the instrument is unaffected when measuring current. When the **mA INPUT** key is pressed again, the display reverts back to the range last selected by the **SELECT K, J, T, mV** key. With mA displayed in the calibrator mode, the alternate calibrator range can be output and displayed by pressing the **OUTPUT LO/HI** key. This provides easier calibration of transmitters by quickly switching to the alternate output range for calibration and/or verification. The mA input is displayed again by pressing the **mA INPUT** key.

The mA input can also accept the voltage output from any transmitter providing a 40 to 200mV calibration output. This is accomplished by a slide switch located inside the battery compartment. The switch is labeled "A" and "B". In the "A" position, the mA input accepts a 4-20mA current. The "B" position accommodates transmitters with a 40-200mV output (the voltage input is converted to a 4-20mA display reading).

### **Operation Guide, Calibrator Mode**

The Thermocouple Calibrator/Indicator uses a compensating reference junction built into the T/C jack. This reference junction is active when the unit is in any of the thermocouple ranges, calibrator or indicator mode. As most temperature indicators or recorders also use an internal reference junction, it is necessary that T/C wire of the proper type be used between the calibrator/indicator and the instrument under calibration. Failure to do so may result in errors of up to  $\pm 10\%$  of reading between the two units. Also refer to "Instrument Connections" on page 8.

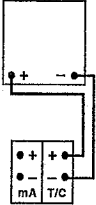
MEASUREMENT TYPE	OPERATION SEQUENCE
<p data-bbox="148 164 420 220"><b>THERMOCOUPLE/mV SOURCE</b></p> <p data-bbox="208 260 358 344"><b>INDICATOR OR RECORDER</b></p>  <p data-bbox="127 667 433 691"><b>CONNECTION DIAGRAM</b></p>	<ol data-bbox="521 164 894 906" style="list-style-type: none"> <li>1. Turn instrument ON. Observe that instrument is in calibrator mode with LO or HI indicated on the LCD.</li> <li>2. Connect instrument T/C output to thermocouple or mV input (standard T/C test leads for mV only; refer to "Instrument Connections" (p. 8).</li> <li>3. Select K, J, T, or mV range.</li> <li>4. Select °F or °C display.</li> <li>5. Select 1° or 0.1° resolution.</li> <li>6. Select LO or HI calibrator output.</li> <li>7. Observe display and adjust appropriate COARSE and FINE controls for desired output setting. Two points of the span can be calibrated by adjusting the LO output for the lower span limit and the HI output for the upper span limit of the calibration range.</li> <li>8. Proceed with calibration, switching between LO and HI calibrator outputs as required for the calibration adjustments.</li> </ol>
<p data-bbox="184 975 370 1031"><b>TRANSMITTER CALIBRATION</b></p>	<ol data-bbox="521 986 894 1385" style="list-style-type: none"> <li>1. Remove battery compartment cover and position slide switch according to type transmitter being calibrated:   The "A" position is for transmitters where the calibrator must be inserted into the 4-20 mA current loop in order to read the output.   The "B" position accommodates transmitters with a 40-200 mV calibration output.   Replace battery compartment cover after positioning the slide switch.</li> </ol>

### TRANSMITTER

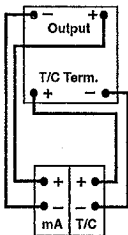

CONNECTION DIAGRAM

### WARNING

Do not open battery compartment or expose instrument's open battery compartment in an explosive or potentially hazardous environment.

2. Turn instrument ON. Observe that instrument is in calibrator mode with LO and HI indicated on the LCD.
3. Remove sensor from transmitter input and connect instrument T/C output to transmitter input using proper type T/C wire. Refer to "Instrument Connections" (p. 8). Connect transmitter output to instrument mA input jacks using test leads supplied. The mA input jacks are color coded and labeled as follows: RED high/positive (+), BLACK low/negative (-).
4. Select K, J, or T range as applicable.
5. Select °F or °C display as applicable.
6. Select 1° or 0.1° resolution as applicable.
7. Select LO or HI calibrator output.
8. Observe display and adjust appropriate COARSE and FINE controls for desired output setting (consult transmitter's specifications or operating instructions for calibration values with appropriate readings). Two points of the span can be calibrated by adjusting the LO output for the lower span limit and the HI output for the upper span limit of the calibration range.
9. Proceed with transmitter calibration, switching display readings between transmitter input (calibrator HI/LO output) and transmitter output (mA input) as required for calibration.



## Indicator Mode

The indicator mode is shown on the display by the absence of HI or LO output indications. If no input is connected to the instrument in the indicator mode, a break detect (open input) condition of three columns of dashes replacing the digit data is shown on the display (same indication as an over-range).

To measure an input, place the instrument in the indicator mode. Connect the input (refer to "Instrument Connections" on page 8) observing proper polarity. Select the appropriate range, resolution, and temperature scale if applicable.

### Operation Guide, Indicator Mode

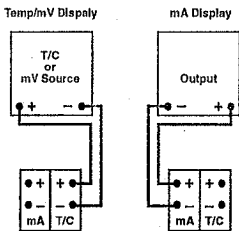
MEASUREMENT TYPE	OPERATION SEQUENCE
<p data-bbox="122 646 461 718"><i>Thermocouple/mV/mA Input</i></p>  <p data-bbox="134 1125 440 1157">CONNECTION DIAGRAM</p>	<ol data-bbox="512 646 906 1380" style="list-style-type: none"> <li>1. Turn instrument ON. Observe that instrument may be in either indicator or calibrator mode with LO or HI indicated on the LCD.</li> <li>2. Select indicator mode by pressing <b>SELECT INDICATE/OUTPUT</b> key. Observe that neither HI or LO is shown on LCD readout.</li> <li>3. Connect thermocouple/mV or mA input to instrument using test leads supplied for mV input or T/C wire for thermocouple input (refer to Instrument Connections on page 8). The mA input jacks are color coded and labeled as follows: <b>RED</b> high/positive (+), <b>BLACK</b> low/negative (-).</li> <li>4. Select K, J, T, mV range or mA Input as applicable.</li> <li>5. Select °F or °C display as applicable.</li> <li>6. Select 1°/0.1° or .1mV/.01mV resolution as applicable.</li> <li>7. Observe and/or record display reading.</li> </ol>

## Maintenance

Normal maintenance of the instrument consists of replacing the battery as required, cleaning the instrument case as required, and calibration once a year as outlined in Section 3, Calibration.

### Battery Replacement

The instrument uses a NEDA 1604 (or equivalent) 9V transistor radio battery. A carbon zinc battery should provide approximately 500 hours of continuous operation.

#### **WARNING!**

**For Thermocouple Calibration/Indicators with Intrinsic safety approval: The replacement battery must be the exact type battery as specified on the approval label on the case bottom.**

When battery voltage reaches approximately 7.3 volts, the display will show a low battery warning by flashing the words "LOW BAT". A minimum of two hours of operation time remains upon initial appearance of the low battery warning - replace the battery at the earliest opportunity. When the battery voltage drops below 6.5 volts, the display will show three columns of dashes (over-range/break detect indication) in addition to the flashing words "LOW BAT".

To replace the battery, remove the battery compartment cover on the case bottom by loosening the allen head retaining screw. Remove the battery by pulling on the connector (not on the wires) and install the new battery. Re-install the battery compartment cover.

#### **WARNING!**

**Do not open the battery compartment or expose the instrument's open battery compartment in an explosive or potentially hazardous environment.**

## **Instrument Cleaning**

The instrument should be cleaned with a soft, damp cloth using mild soap and water. To effectively remove grease or heavy oils from the instrument, non-abrasive mechanics soap may be used. Abrasive cleaning agents should not be used for cleaning the instrument.

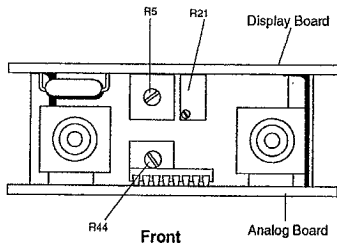
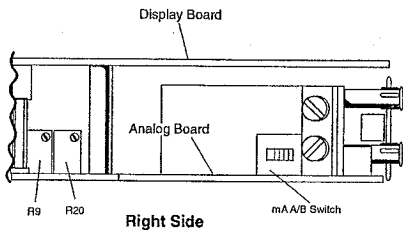
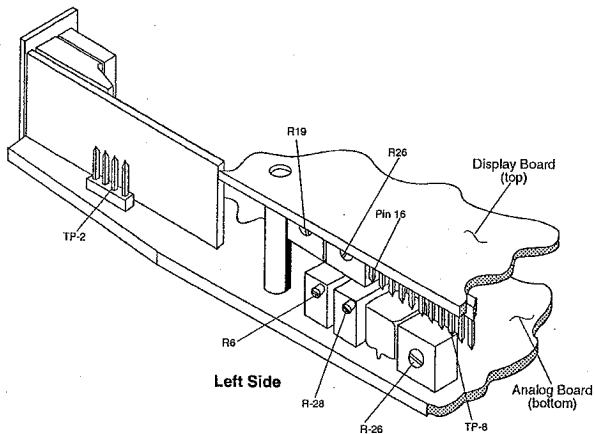

**Figure 3. Potentiometer Adjustment Testpoint Locations**

## Calibration Procedure

### Equipment Required

4-1/2 digit, digital voltmeter

Precision mV/mA source:

resolution  $1\mu\text{V}/\mu\text{A}$ ; accuracy  $\pm .01\%$  ( $\pm 2\mu\text{V}$ )

Recirculating ice bath,  $0.00^\circ\text{C} \pm .05^\circ\text{C}$

Type K thermocouple wire

Copper hookup wire

Potentiometer adjusting tool

Refer to Figure 3 for locations of pot adjustments and testpoints.

### mV Calibration

- Step 1** Remove battery from instrument (refer to Battery Replacement). Remove bottom case half from printed circuit board assemblies by extracting three screws from case bottom and one screw holding wrist strap lug. Remove top case half from printed circuit board assemblies by extracting screw on clad side of Analog Board between output controls. Re-connect battery to connector.
- Step 2** Measure voltage at TP-8 (+) on Display Board (top board) with DVM common (-) at TP-2 on Analog Board (bottom board). Voltage at TP-8 should be between 3.680-3.720 V. If measured voltage is outside of range, adjust R9 on Analog Board for DVM reading at TP-8 of 3.695V.
- Step 3** Set instrument to indicator mode, mV input.
- Step 4** Connect precision mV/mA calibrator source to T/C input observing proper polarity.
- Step 5** Adjust source output to 0.000mV (short).

- Step 6** Select high resolution display (.00 mV). Display should read .00 with flashing minus sign. Turn R21 clockwise: display should read .00, .01, .02, .03. Turn R21 counterclockwise: display should read .03, .02, .01, .00, -.00, -.01, -.02, -.03. Adjust R21 for display reading of .00 with flashing minus sign. If reading is not stable, R26 on the Analog Board may need adjusting (normally adjusted near center).
- Step 7** Adjust source output to -7.000mV.
- Step 8** Adjust R28 on Analog Board for an exact display reading of -7.00mV.
- Step 9** Adjust source output to 0.000mV, check zero reading and adjust R21 on Display Board as required for correct (.00) reading.
- Step 10** Adjust source output to + 27.000mV.
- Step 11** Adjust R9 on Analog Board for an exact display reading of 27.00mV.
- Step 12** Repeat steps 7 through 11 as required until no further adjustment is required for correct display readings.
- Step 13** Switch instrument to low resolution display (.0) and verify display readings of -7.0 mV, 0.0mV, and 27.0mV with an input of -7.00mV, 0.000mV, and 27.000mV respectively.
- Step 14** Perform temperature calibration as outlined in the following procedure

### **Temperature Calibration**

This procedure requires a recirculating ice bath and a Type K thermocouple probe and a precision millivolt/microvolt source. The probe is constructed as follows: With a suitable length of Type K thermocouple wire and copper hookup wire, form junctions between each thermocouple wire (HI and LO) with a length of copper wire. Electrically isolate these junctions and insert both junctions in a recirculating ice bath. The calibration setup is shown in Figure 4.

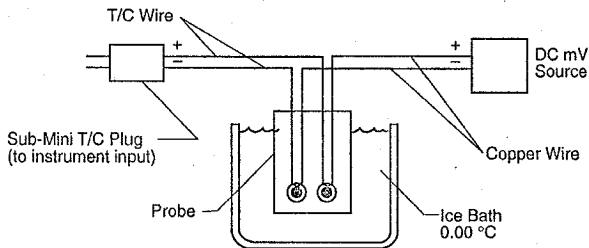

**Figure 4. Calibration Setup**

- Step 1** Set instrument to indicator mode, Type K range, 0.1° resolution, °F scale.
- Step 2** Observing proper polarity, connect the thermocouple wires from the ice bath to the instrument T/C input.
- Step 3** Observing proper polarity, connect the copper wires from the ice bath to the calibrator source.
- Step 4** Adjust source output to 0.000mV (short). Allow 15 minutes for stabilization.
- Step 5** Adjust R6 on Analog Board for display reading of 32.0°F.
- Step 6** Adjust source output to -4.513mV.
- Step 7** Adjust R28 on Analog board for a display reading of  
|  
-209.0°F.
- Step 8** Recheck display with zero input. Adjust R6 as required for a display reading of 32.0°F.
- Step 9** Adjust source output to +7.848mV.
- Step 10** Adjust R9 on Analog Board for a display reading of 379.0°F.
- Step 11** Repeat steps 6 through 10 until no further adjustments are required for correct display readings.
- Step 12** Set instrument to indicator mode, mV input.

- Step 13** Check the display reading with the following inputs: -7.000 mV (-7.00 mV display), 0.000 mV (.00 mV display), + 27.00 mV display. All readings should be within a tolerance of  $\pm .01$  mV. If not, the entire calibration procedure must be repeated.
- Step 14** Perform mA input calibration as outlined in the following procedure:

### **mA Input Calibration**

- Step 1** Observing proper polarity, connect precision mA source to mA input jacks of instrument.
- Step 2** Set instrument to mA input mode.
- Step 3** Set mA A/B switch to "A" position.
- Step 4** Adjust source output to 0.000mA.
- Step 5** Adjust R5 on Display Board for a display reading of .00mA.
- Step 6** Adjust source output to 25.000mA.
- Step 7** Adjust R20 on Analog Board for a display reading of 25.00mA.
- Step 8** Repeat steps 4 through 7 until no further adjustments are required for correct display readings.
- Step 9** Carefully reassemble instrument.

**CALIBRATION COMPLETED**



## **General**

The calibrator/indicator unit is physically divided into two printed circuit board assemblies: the Analog Board, and the Display Board. Functionally, the instrument consists of two main sections: a DC mV source, and a TC/mV/mA indicator.

Two custom CMOS integrated circuits are utilized to digitize and display the analog input signals.

Integrated circuit Z2 on the Analog Board performs the conversion of the analog input to the digital equivalent via a dual-slope integrator coupled to a zero-cross detect amplifier. A patented low noise, high gain amplifier is used as an integrator. Battery voltage is also monitored by this IC. Integrated circuit Z3 on the Analog Board supplies the reference junction correction signal for thermocouple inputs. IC Z2 uses three low power opamps for a total current consumption of 30 $\mu$ A.

IC Z12 on the Display Board is comprised of LSI digital circuitry. This IC provides the timing signals for the analog circuitry of IC Z2 on the Analog Board and senses the axis crossing of the dual slope converter. An internal counter, in conjunction with a ROM controlled binary rate multiplier, performs a piece-wise linearization on the signal. IC Z12 stores the linearized result and directly drives the LCD readout.

Seven separate, normally open, momentary contact, push button switches on the Display Board comprise the instrument keyboard. These switches are gated by CMOS gates and switches in order to drive various LCD segments and/or address the custom LSI IC Z12.

## **DC mV Source**

The DC millivolt source circuitry is located on the Analog Board. The main components of the source circuitry are energized by the application of the CAL signal. When the instrument is in the indicator mode, battery power is conserved by deactivating the source circuitry with CAL off.

According to the state of the HI/LOW line, multiplexer Z4, channels X and Y, selects either the left pot tandem (R40 and R41) or right pot tandem (R42 and R43) to control the output of the source. Multiplexer Z4, channels W and Z, controls which of the two source LCD indicators are darkened (HI or LO) by applying either the 40Hz BP or 40Hz BP signal (on and off respectively) to the appropriate LCD indicator. Multiplexer Z7, channel X, applies BP to both LCD source indicators when the instrument is in the indicator mode. The selected pot tandem is provided as input to the unity gain chopper amplifier consisting of Q4 - Q7, Z5, Z6 and associated components. This scheme is utilized to prevent output drift, thus providing a stable output.

The output from opamp Z6 is input to multiplexer Z7, channels Y and Z, for routing to the SIG HIGH line for measurement and output from J1. When the source deactivated (CAL off), the output from Z6 is removed from the SIG HIGH line and tied to  $V_{ss}$ .

## **Indicator Section**

### **Isolated mA Input**

Refer to the Analog Board schematic. The mA input is applied to shunt resistor R18 in the normal current measuring mode. The shunt resistor is removed and the signal passed directly when the instrument is used to accept voltage input from those transmitters provided with a calibration voltage output. Fuse F2 and zeners CR4 and CR5 (CR5 not used on some applications) provide input protection. Capacitor C6 decouples spurious noise from the signal input.

Transformer T2 and rectifier CR7 are used to provide isolated power to multiplexer Z8 which is used to convert the mA signal to AC. The AC mA signal is transformer coupled by T1 to multiplexer Z1, channels Y and Z, where it is synchronously rectified by switching the Y and Z input on the alternate phase from the T1 secondary. The mA input signal is thus totally isolated from the rest of the instrument circuitry.

Trimmer R20 provides adjustable voltage gain for the signal to compensate for transmission losses incurred by the switching scheme.

Multiplexer Z1, channel X, selects the input/output, thermocouple/mV or mA, to be present at the  $V_{IN}$  input of Z2 pin 7 for measurement and display. Multiplexer Z1 passes the mA signal (Z1 pin 13) to the  $V_{IN}$  input at Z2 pin 7 when the MA SEL signal at pin 11 is high. If the MA SEL signal is low, the TC/mV input at Z1 pin 12 is passed instead to the  $V_{IN}$  input at Z2 pin 7.

### **Thermocouple/mV Input**

Refer to the Analog Board schematic. Thermocouple and mV inputs are connected to connector J1. The calibrator source for these ranges is also output from J1. Fuse F1 and diodes CR1 and CR2 (CR2 not used on some applications) provide input protection. Capacitor C1 decouples spurious noise from the input. The thermocouple/mV input/output is routed to multiplexer Z1 pin 12 where it is input to IC Z2 by a low MA SEL signal at Z1 pin 11. The input selection is controlled by the MA SEL as described above in the isolated mA input.



## Functional

### Input Impedance (Indicator Mode):

Thermocouple and mV: greater than 13M $\Omega$

Isolated mA: "A" setting, approximately 11 $\Omega$ ; "B" setting, 50k $\Omega$  minimum.

**Output Impedance (Calibrator Mode):** Less than 100 $\Omega$  up to 250nA.

**Overload Protection:** Input fuse and diode clamping protection.

**Display:** 3 <sup>3</sup>/<sub>4</sub> digit liquid crystal display (LCD) with 0.4" (10 mm) digit height.

**Turn On Time:** 5 seconds.

**Battery:** Instrument requires one 9V transistor radio battery, NEDA 1604 or equivalent. Battery provides approximately 500 hours of continuous operation in Calibrator mode. In the indicator mode, battery life is doubled.

### Range/Span/Resolution (Input/Output)

Range	Span	Resolution
J	-179.4°F to +398.3°F (-117.4°C to +203.5°C)	0.1°
	-318°F to +1858°F (-194°C to 1° +1014°C)	1°
K	-219.7°F to +398.7°F (-139.8°C to +203.7°C)	0.1°
	-308°F to +2501°F (-189°C to +1372°C)	1°
T	-234.8°F to +399.0°F (-148.2°C to +203.9°C)	0.1°
	-360°F to +758°F (-217°C to +403°C)	1°
mV*	-37.3mV to +111.9mV	0.1mV
	-9.32mV to +27.98mV	0.01mV
mA	0.00mA to 27.98mA	0.01mA

\*mV Output: -10.0 mV to +110.0 mV

## Performance

### Noise Rejection

NMRR: 50dB @ 50/60Hz  $\pm$  1Hz, 0.1° range.

35dB @ 50/60Hz  $\pm$  1Hz, 1° range.

CMRR (100 $\Omega$  unbalanced): 140dB @ 50/60Hz  $\pm$  1Hz, 0.1° range. 120dB @ 50/60Hz  $\pm$  1Hz, 1° range.

### Accuracy at 72 °F: $\pm 5$ °F (22°C, $\pm 3$ °C)

K, J, and T Thermocouple Input/Output:

1° range:  $\pm 1.8$ °F  $\pm 0.1\%$  rdg. ( $\pm 1$ °C  $\pm 0.1\%$  rdg.).

0.1° range:  $\pm 0.45$ °F  $\pm 0.1\%$  rdg. ( $\pm 0.25$ °C  $\pm 0.1\%$  rdg.)

mV Input/Output:

0.1mV range:  $\pm 0.1\%$  rdg.  $\pm 1$  count

0.01mV range:  $\pm 0.1\%$  rdg.  $\pm 2$  counts

mA Input:

0.01mA range:  $\pm 0.1\%$  rdg.  $\pm 2$  counts

### Stability With Time

90 days: add  $\pm 0.05\%$  rdg.

1 year: add  $\pm 0.1\%$  rdg.

### Stability With Temperature

Zero:  $\pm 1.1$  $\mu$ V per °F ( $\pm 2$  $\mu$ V per °C)

Span:  $\pm 0.01\%$  rdg. per °F  $\pm 0.02\%$  rdg. per °C)

Reference Junction Tracking:

$\pm 1.8$ °F from 41 °F to 113°F ( $\pm 1$ °C from 5 °C to 45 °C)

$\pm 2.7$ °F from -4 °F to 131°F ( $\pm 1.5$ °C from 20 °C to 55 °C)

## **Physical/Environment**

**Hazardous Locations:** Factory Mutual and CSA intrinsically safe certification for Class I, Division 1 and 2, Groups C and D (approval pending). Intrinsically Safe Certification per the CENELEC standards for Gas Groups IIB and IIA, Zone 1 (approval pending). See label at bottom of instrument for applicable approvals.

### **EMI/RFI Effect:**

Meets or exceeds SAMA PMC 33.1, 2 abc: 1% range shift.

**Operating Range:** -4 to 131 °F (-20 to 55°C)

**Storage Range:** -22 to 140 °F (-30 to 60 °C)

**Relative Humidity:** 0 to 90%, noncondensing to 99°F (37°C)

**Size:** 3.75" W x 2.75" H x 8.35" L  
(9.5 cm x 7 cm x 21.2 cm)

**Weight:** Approximately 16 oz. (454 grams).





## Schematic Diagrams/Assembly Drawing



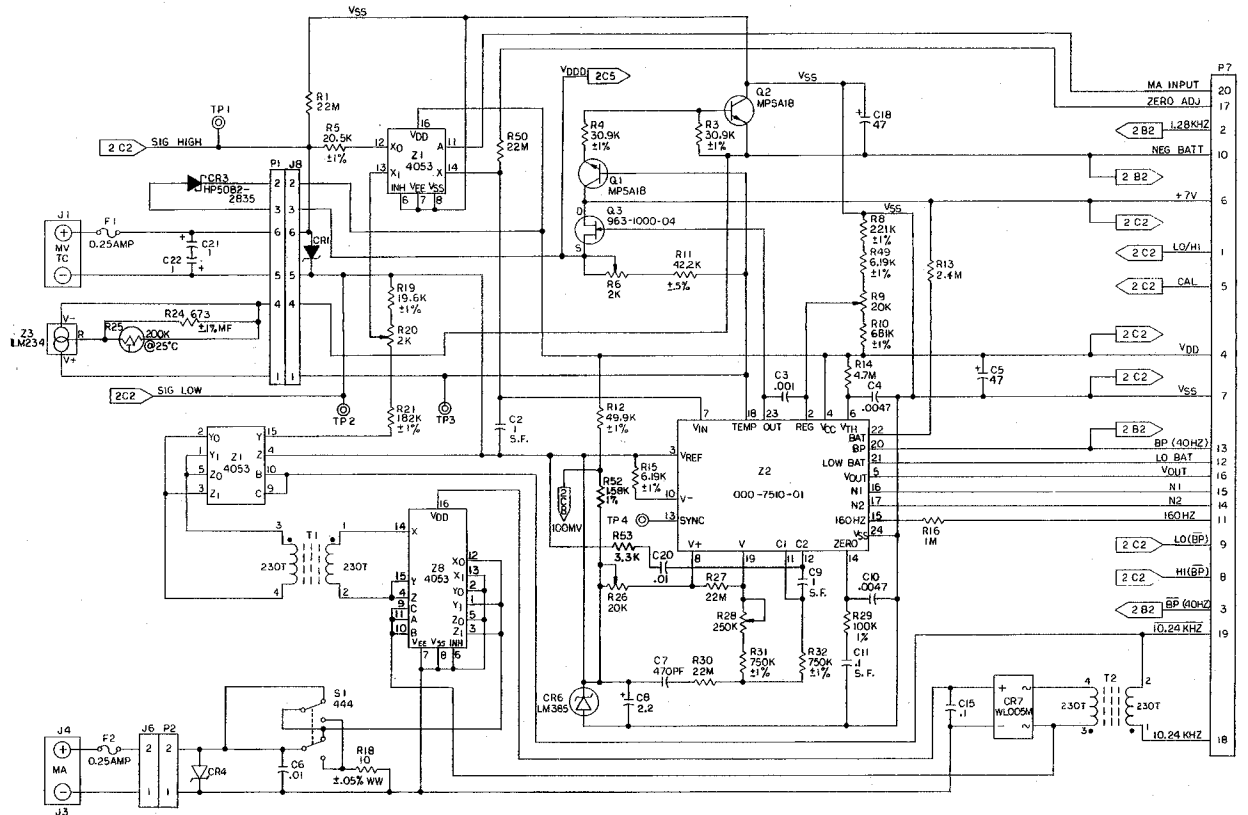

**Schematic Diagram  
Analog Board  
1 of 2**

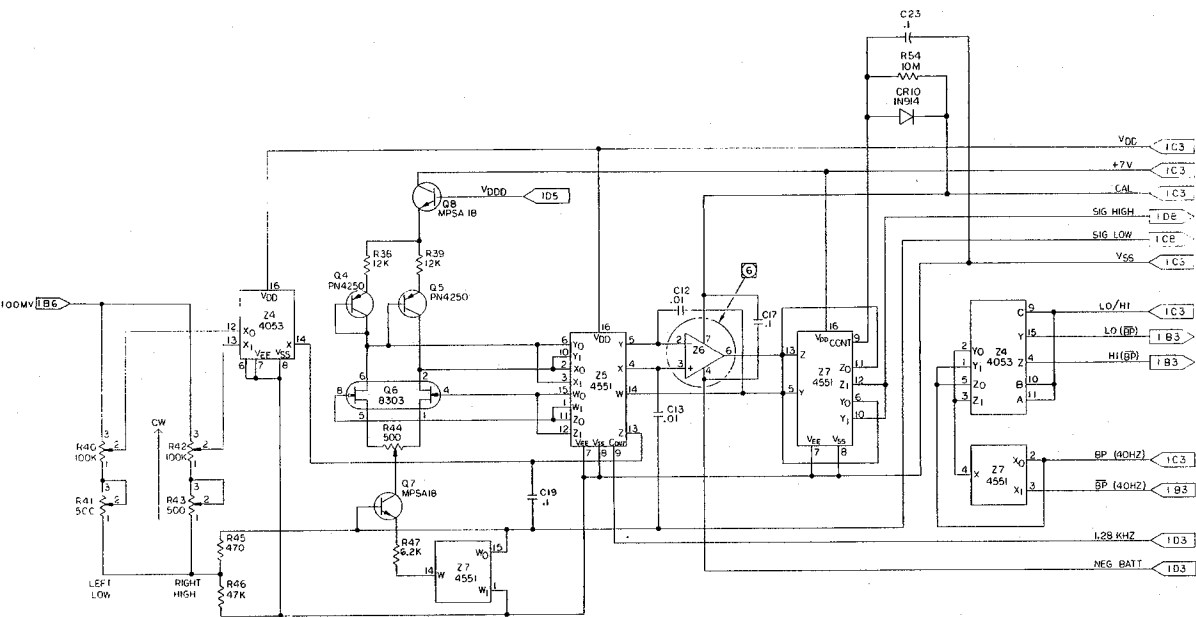

**Schematic Diagram**  
**Analog Board**  
 2 of 2

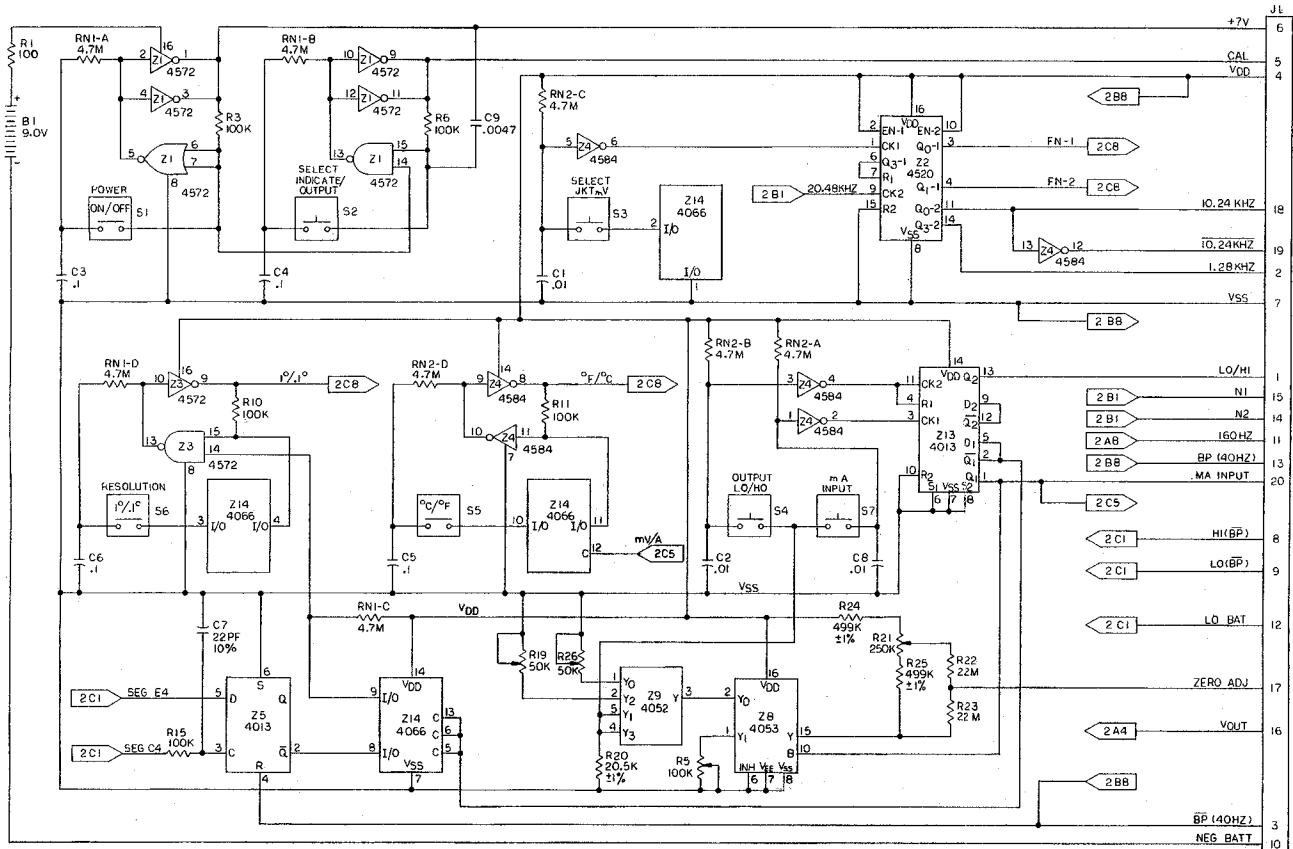

**Schematic Diagram  
Display Board  
1 of 2**



**Thermocouple  
Calibrator/Indicator  
Assembly, Exploded View**

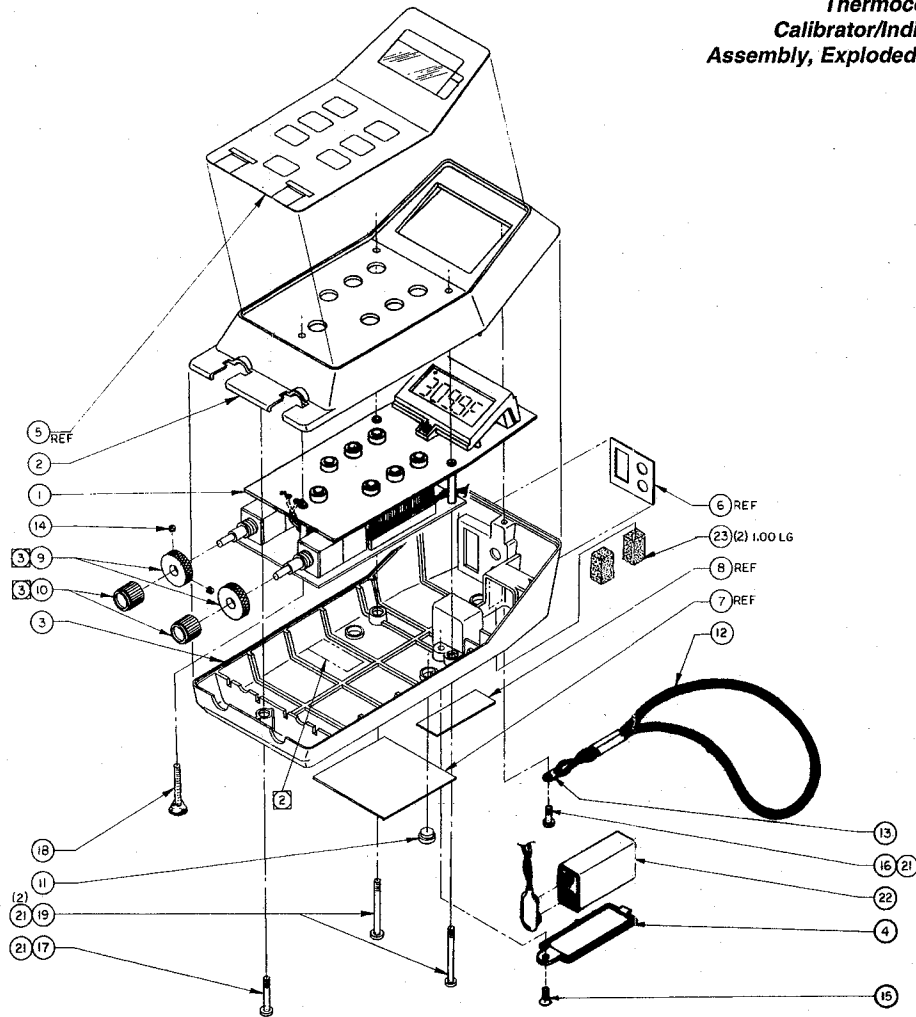

# Assembly Parts List

Item No.	Part Description	No. Req.
1	Assy, Calibrator Boards	1
2	Case, Top	1
3	Case, Bottom	1
4	Cover, Battery	1
5	Overlay, Front	Ref
6	Overlay, Input	Ref
7	Label, Instruction	Ref
8	Label, Certifications	Ref
9	Thumbwheel	2
10	Knob, Rogan RB-67-0-M, Black	2
11	Foot, Rubber	5
12	Assy, Wrist strap	1
13	Eyelet	1
14	Set Screw, Allen 4-40 x 1/8 Lg.	4
15	Screw, Flat Head, Phillips 4-40 x 1/4 Lg.	1
16	Screw, Pan Head, Phillips 4-40 x 3/8 Lg.	1
17	Screw, Pan Head, Phillips 4-40 x 1-5/8 Lg.	1
18	Screw, Pan Head, Phillips 4-40 x 1-1/16 Lg.	1
19	Screw, Pan Head, Phillips 4-40 x 2-1/2 Lg.	2
20	Washer, .096 I.D., .010" Thk, Nyl	1
21	Washer, Splitlock #4	5
22	Battery, 9V	1
23	Foam, Adhesive Backed 1/8"T x 1/2"W	4"