

## MODEL CSSG1 – MODULAR CONTROLLER SERIES STRAIN GAGE MODULE



- STRAIN GAGE MODULE FOR THE MODULAR CONTROLLER SERIES
- HOT-SWAPPABLE REPLACEMENT REDUCES DOWNTIME
- AUTO ADDRESSING MINIMIZES CONFIGURATION TIME
- PID CONTROL WITH REDUCED OVERSHOOT
- LOAD CELL, PRESSURE AND TORQUE BRIDGE INPUTS
- SOFTWARE SELECTABLE LOW LEVEL INPUTS (20 mV, 33 mV or 200 mV FULL SCALE)
- SOFTWARE SELECTABLE 5 VDC or 10 VDC BRIDGE EXCITATION
- DIGITAL TARE (re-zero), BATCH TOTALIZER, AND PEAK/VALLEY (max/min) RECORDING
- ON DEMAND AUTO-TUNING OF PID SETTINGS
- DC ANALOG OUTPUT
- WINDOWS® CONFIGURATION SOFTWARE



### GENERAL DESCRIPTION

The Model CSSG is a full featured single loop PID controller designed for use with the Modular Controller Series. The module accepts low level signals from a variety of bridge-type transducers, such as load cells, pressure transducers, torque transducers, etc. An optional second signal input is available, providing math capabilities between the two input channels (average, differential, etc.). Each input channel provides a software selectable 5 V or 10 V stable bridge excitation voltage, capable of driving up to four 350 Ω bridges (combined total per module). The inputs are software selectable for ±20 mV, ±33 mV, or ±200 mV full scale. With solid state or relay outputs, plus an analog output, the CSSG module can perform virtually any combination of time-proportioning or linear control. The discrete outputs may also be assigned to one of seven internal soft alarms; and the linear output can be assigned to transmit virtually any internal variable. In addition, digital tare (re-zero), batch totalizer, and peak/valley (max/min) are provided.

The modules connect and communicate via a backplane connection to the CSMSTR Master module. The Master, equipped with serial ports as well as an Ethernet port, allows the system to share data with PCs, PLCs, and SCADA systems. The Master supports up to 16 CS Series modules (when using CSSG modules, refer to "Power" specifications).

The CSSG modules are available with relays, or open drain MOSFET outputs. For applications requiring large loads to be controlled, several DIN rail mount relays are available.

The modules can operate in On/Off, P, PI, or PID control mode, and use an on-demand Auto-Tune that establishes the tuning constants. The PID constants may be fine-tuned through the serial or Ethernet interface. The modules employ a unique overshoot suppression feature, which allows the quickest response without excessive overshoot. The modules can also be operated in manual mode, providing the operator with direct control of the output.

Internal power management circuits allow the modules to be replaced while power is applied, which reduces downtime in the event of a relay failure. All configuration information is stored locally within each module, as well as in the Master, so replacement modules do not need to be configured.

The Modular Controller Series' high density packaging and DIN rail mounting saves time and panel space. The backplane connection provides power and communication to the module and snaps easily onto standard top hat (T) profile DIN rail.

### CONFIGURATION

The Modular Controller Series is configured with Windows® compatible Crimson® software. The software is an easy to use, graphical interface which provides a means of configuration and commissioning of new systems, as well as routine module re-calibration.

### SAFETY SUMMARY

All safety related regulations, local codes and instructions that appear in the manual or on equipment must be observed to ensure personal safety and to prevent damage to either the instrument or equipment connected to it. If equipment is used in a manner not specified by the manufacturer, the protection provided by the equipment may be impaired.

Do not use the controller to directly command motors, valves, or other actuators not equipped with safeguards. To do so can be potentially harmful to persons or equipment in the event of a fault to the controller.

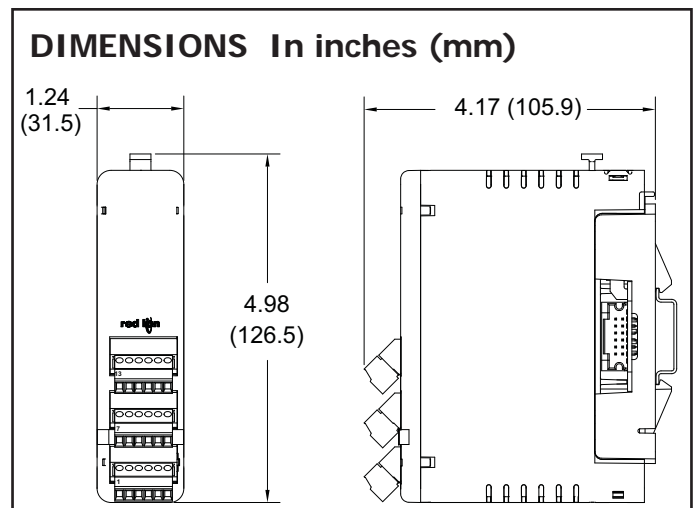
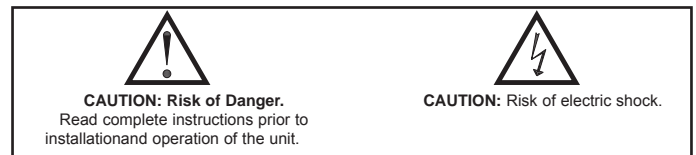

# SPECIFICATIONS

1. **POWER:** Derived from system backplane. 250 mA max. load on power input of MASTER. Module may be hot-swapped (replaced while powered up).  
 Modules per Master: A single Master can support up to 11 CSSG1 modules combined with any 5 other module types. For applications that require more than 11 CSSG1 modules, please contact technical support.

2. **LEDs\*:**

STS - Status LED shows module condition.  
 OP1, OP2, OP3 - Indicate status of outputs 1, 2, and 3  
 ALM - Alarm LED is lit during an internal alarm condition.  
 \* Default configuration.

3. **MEMORY:** Non-volatile memory retains all programmable parameters. The MASTER also stores the parameters in order to reprogram any modules that are replaced.

4. **INPUTS:**

SOFTWARE SELECTABLE INPUT RANGE	ACCURACY * 18 TO 28°C 10 TO 75% RH	ACCURACY * 0 TO 50°C 0 TO 85% RH
±20.000 mVDC	0.02% of reading +3 µV	0.07% of reading +4 µV
±33.000 mVDC	0.02% of reading +5 µV	0.07% of reading +7 µV
±200.00 mVDC	0.02% of reading +30 µV	0.07% of reading +40 µV

\* After 20 minute warm-up. Accuracy over the 0 to 50°C range includes the temperature coefficient.

Connection Type:

- 4-wire bridge (differential)
- 2-wire (single-ended)

Sample Time: 67 msec (15 readings per second)

Common Mode Range (with respect to input common): 0 to +5 VDC

Common Mode Rejection: > 100 dB, DC to 120 Hz

Temperature Coefficient (ratio metric): 20 ppm/°C max.

Step Response Time: 200 msec max. to within 99% of final process value

Input Impedance: 100 MΩ

Max Continuous Overload: 30 V

PV Range: -30,000 to 30,000

Effective Resolution: 16-bit

5. **BRIDGE EXCITATIONS:**

Software selectable:

- 5 VDC, ±2%, 65 mA max.
- 10 VDC, ±2%, 125 mA max. combined (excitation 1 plus excitation 2).

Temperature coefficient (ratio metric): 20 ppm/°C max.

Max. four 350Ω bridges per module.

6. **ISOLATION LEVEL:** 500 Vrms @ 50/60 Hz for 1 minute between the following:

- OP1 \*
- OP2 \*
- OP3

Linear Output

Signal Inputs (the 2 input channels are not isolated from each other)

CS Master Power Supply Input

\* Outputs OP1 and OP2 of SSR model are not isolated from each other

7. **COMMUNICATIONS:** Provided by the CS Master.

8. **DISCRETE OUTPUTS:**

Outputs 1 and 2 are available as Solid State NFET, or Form A relay. Output 3 is a Form C relay.

Solid State Output:

- Type: Switched DC, N Channel open drain MOSFET
- Current Rating: 1 A max
- VDS ON: 0.3 V @ 1 A
- VDS MAX: 30 VDC
- Offstate Leakage Current: 0.5 mA max

Form A Relay Output:

- Type: N.O.
- Current Rating: 3 Amps @ 125 VAC
- 1/10 HP @ 125 VAC

Life Expectancy: 200,000 cycles at maximum load rating. (Decreasing load, increasing cycle time, and use of surge suppression such as RC snubbers increases life expectancy.)

Form C Relay Output:

- Type: SPDT
- Current Rating: 5 Amps @ 125 VAC or 28 VDC (resistive load)
- 1/8 HP @ 125 VAC

Life Expectancy: 100,000 cycles at maximum load rating. (Decreasing load, increasing cycle time, and use of surge suppression such as RC snubbers increases life expectancy.)

9. **CONTROL MODES:**

Control: On/Off, P, PI, or PID

Output: Time proportioning or linear

Cycle Time: Programmable from 0.0 to 60.0 sec

Auto-Tune: When selected, sets proportional band, integral time, derivative time values, and output dampening time

Input Fault Response: Upscale

10. **ALARMS:**

Modes: Manual

- Absolute High Acting      Absolute Low Acting
- Deviation High Acting      Deviation Low Acting
- Inside Band Acting      Outside Band Acting

Reset Action: Programmable; automatic or latched

Standby Mode: Programmable; enable or disable

Hysteresis: Programmable

Input Fault Response: Upscale

11. **ANALOG DC OUTPUT:**

Jumper Selectable/programmable for 0-10 VDC, 0-20 mA, or 4-20 mA

Resolution:

- Voltage: 500 µV
- Current: 1 µA

Accuracy:

- 0.1% of full scale (18 to 28°C)
- 0.2% of full scale (0 to 50°C)

Update Time: 0.0 to 60.0 sec

Compliance (for current output only): 500 Ω max.

Minimum load (voltage output only): 10 KΩ min.

Output is independently jumper selectable for either 10 V or 20 mA. The output range may be field calibrated to yield approximate 10% overrange and a small underrange (negative) signal.

12. **ENVIRONMENTAL CONDITIONS:**

Operating Temperature Range: 0 to +50°C

Storage Temperature Range: -40 to +85°C

Operating and Storage Humidity: 85% max relative humidity, non-condensing, from 0 to +50°C

Vibration According to IEC 68-2-6: 10 to 150 Hz, 0.075 mm amplitude in X, Y, Z direction 1 g.

Shock According to IEC 68-2-27: Operational 25 g's (10 g's relay), 11 msec in 3 directions.

Altitude: Up to 2000 meters

13. **CERTIFICATIONS AND COMPLIANCES:**

**SAFETY**

UL Listed, File # E302106, UL508, CSA C22.2 No. 14-M05

LISTED by Und. Lab. Inc. to U.S. and Canadian safety standards

IEC 61010-1, EN 61010-1: Safety requirements for electrical equipment for measurement, control, and laboratory use, Part 1.

**ELECTROMAGNETIC COMPATIBILITY**

Emissions and Immunity to EN 61326: 2006: Electrical Equipment for Measurement, Control and Laboratory use.

**Immunity to Industrial Locations:**

Electrostatic discharge	EN 61000-4-2	Criterion B 4 kV contact discharge 8 kV air discharge
Electromagnetic RF fields	EN 61000-4-3	Criterion B <sup>3</sup> 10 V/m
Fast transients (burst)	EN 61000-4-4	Criterion B power 2 kV I/O signal 1 kV
Surge	EN 61000-4-5	Criterion B I/O signal connected to power 2 kV power 1 kV L-L, 2 kV L-G signal 1 kV
RF conducted interference	EN 61000-4-6	Criterion A 3 V/rms

**Emissions:**

Emissions      EN 55011      Class A

Notes:

1. Criterion A: Normal operation within specified limits.
2. Criterion B: Temporary loss of performance from which unit self-recovers.
3. The module's analog input and/or output signals may deviate during disturbance but self-recover when disturbance is removed.
4. Power supplied from backplane via Master Module.

14. **CONSTRUCTION:** Case body is burgundy high impact plastic. Installation Category I, Pollution Degree 2.

15. **CONNECTIONS:** Removable wire clamp screw terminal blocks.

Wire Gage: 28-16 AWG terminal gage wire

Torque: 1.96-2.23 inch/lbs (0.22-0.25 N-m)

16. **MOUNTING:** Snaps on to standard DIN style top hat (T) profile mounting rails according to EN50022 -35 x 7.5 and -35 x 15.

17. **WEIGHT:** 7 oz (198.4 g)

## BLOCK DIAGRAM

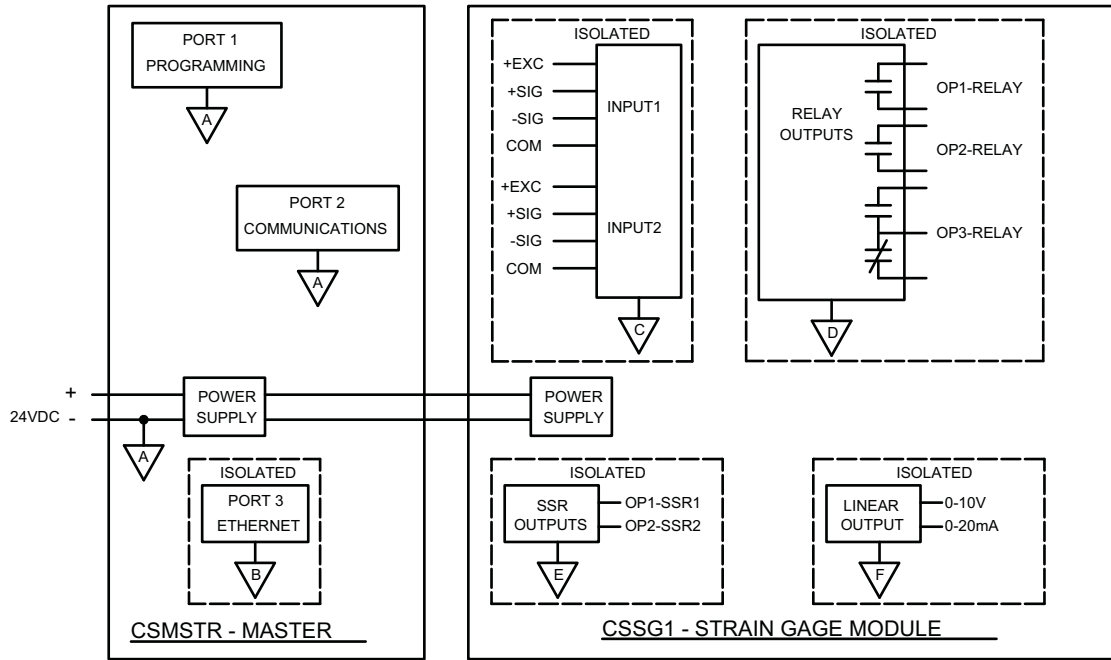

## EMC INSTALLATION GUIDELINES

Although Red Lion Controls Products are designed with a high degree of immunity to Electromagnetic Interference (EMI), proper installation and wiring methods must be followed to ensure compatibility in each application. The type of the electrical noise, source or coupling method into a unit may be different for various installations. Cable length, routing, and shield termination are very important and can mean the difference between a successful or troublesome installation. Listed are some EMI guidelines for a successful installation in an industrial environment.

1. A unit should be mounted in a metal enclosure, which is properly connected to protective earth.
  - a. The mounting clip that connects to the DIN rail should have the DIN rail connected to protective earth.
2. Use shielded (screened) cables for all Signal and Control inputs. The shield (screen) pigtail connection should be made as short as possible. The connection point for the shield depends somewhat upon the application. Listed below are the recommended methods of connecting the shield, in order of their effectiveness.
  - a. Connect the shield to earth ground (protective earth) at one end where the unit is mounted.
  - b. Connect the shield to earth ground at both ends of the cable, usually when the noise source frequency is over 1 MHz.
  - c. Connect the shield to common of the module and leave the other end of the shield unconnected and insulated from earth ground.
3. Never run Signal or Control cables in the same conduit or raceway with AC power lines, conductors feeding motors, solenoids, SCR controls, and heaters, etc. The cables should be run through metal conduit that is properly grounded. This is especially useful in applications where cable runs are long and portable two-way radios are used in close proximity or if the installation is near a commercial radio transmitter. Also, Signal or Control cables within an enclosure should be routed as far away as possible from contactors, control relays, transformers, and other noisy components.
4. Long cable runs are more susceptible to EMI pickup than short cable runs. Therefore, keep cable runs as short as possible.

5. In extremely high EMI environments, the use of external EMI suppression devices such as Ferrite Suppression Cores for signal and control cables is effective. The following EMI suppression devices (or equivalent) are recommended:

Fair-Rite part number 0443167251 (RLC part number FCOR0000)

TDK part number ZCAT3035-1330A

Steward part number 28B2029-0A0

6. To protect relay contacts that control inductive loads and to minimize radiated and conducted noise (EMI), some type of contact protection network is normally installed across the load, the contacts or both. The most effective location is across the load.
  - a. Using a snubber, which is a resistor-capacitor (RC) network or metal oxide varistor (MOV) across an AC inductive load is very effective at reducing EMI and increasing relay contact life.
  - b. If a DC inductive load (such as a DC relay coil) is controlled by a transistor switch, care must be taken not to exceed the breakdown voltage of the transistor when the load is switched. One of the most effective ways is to place a diode across the inductive load. Most RLC products with solid state outputs have internal zener diode protection. However external diode protection at the load is always a good design practice to limit EMI. Although the use of a snubber or varistor could be used.  
RLC part numbers: Snubber SNUB0000  
Varistor ILS11500 or ILS23000

*Note: Reference manufacturer's instructions when installing any EMI suppression device.*
7. Also care should be taken when connecting input and output devices to the instrument. When a separate input and output common is provided, they should not be mixed. Therefore a sensor common should NOT be connected to an output common. This would cause EMI on the sensitive input common, which could effect the instruments, operation.

Visit RLC's web site at [www.redlion.net](http://www.redlion.net) for more information on EMI guidelines, Safety and CE issues as they relate to Red Lion Controls products.

# HARDWARE

## ANALOG OUTPUT OPTION

Select either Voltage or Current output by placing the output jumpers in the appropriate location. The output jumpers are located on the side of the CSSG1 module.

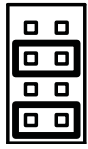

Current

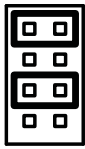

Voltage

## INSTALLATION

### SEPARATE BASE FROM MODULE

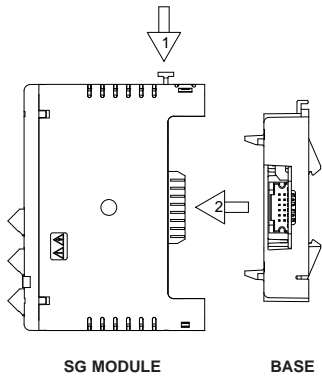

### ATTACH THE MODULE BASE TO THE DIN RAIL

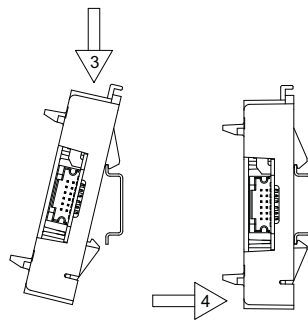

### ATTACH MODULE TO BASE

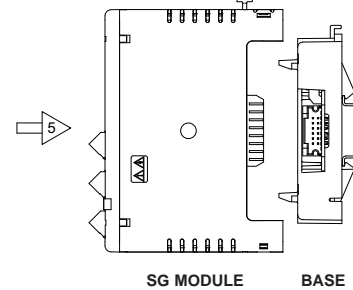

## WIRING

### WIRING CONNECTIONS

All conductors should meet voltage and current ratings for each terminal. Also, cabling should conform to appropriate standards of good installation, local codes and regulations. When wiring the module, use the numbers on the label to identify the position number with the proper function. Strip the wire, leaving approximately 1/4" (6 mm) of bare wire exposed. Insert the wire into the terminal, and tighten.

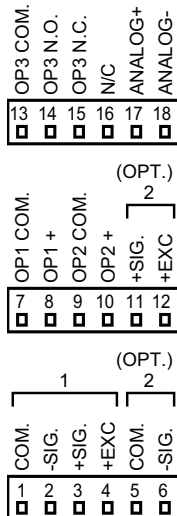
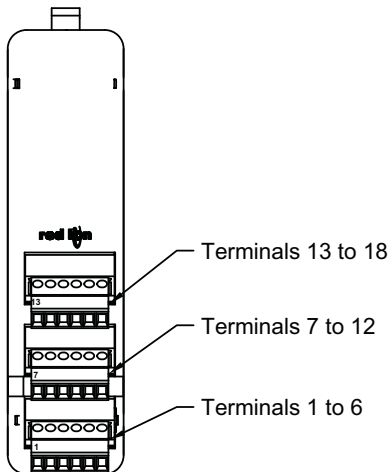

## INPUT CONNECTIONS

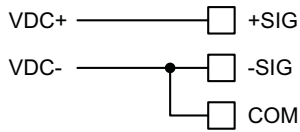

2-Wire Single Ended Input

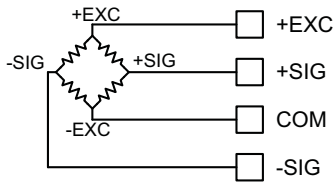

4-Wire Bridge Input

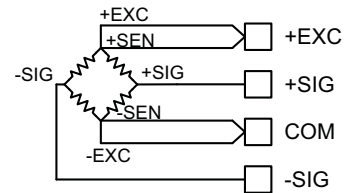

6-Wire Bridge Input

## BRIDGE COMPLETION RESISTORS

For single strain gage applications, bridge completion resistors must be employed externally to the module. Only use metal film resistors with a low temperature coefficient of resistance.

Load cells and pressure transducers are normally implemented as full resistance bridges and do not require bridge completion resistors.

## OUTPUT CONNECTIONS

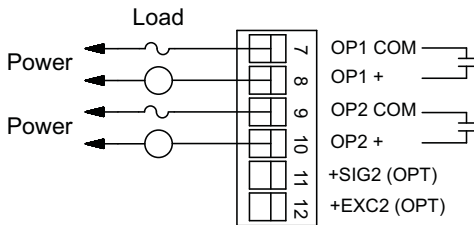

Outputs 1 and 2 - Relay Version

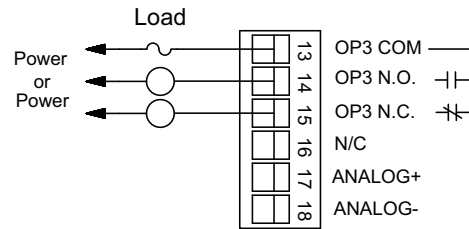

Output 3

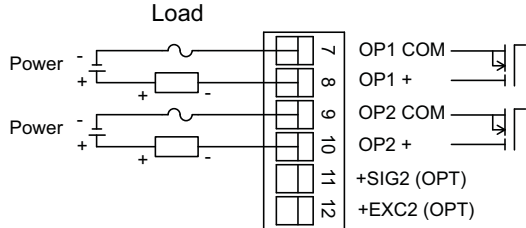

Outputs 1 and 2 - Solid State Version

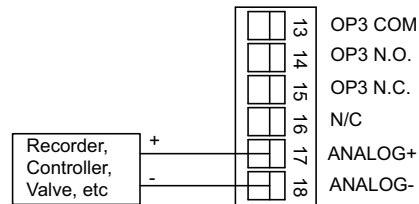

Analog Output

## LEDS

### STS – STATUS LED

The Status LED is a dual color LED that provides information regarding the state of the module. This includes indication of the various stages of the start-up routine (power-up), as well as any errors that may occur.

#### Startup Routine

Rapidly Flashing Red	Module is currently running the boot loader and/or being flash upgraded by Crimson. This occurs for four seconds during a power up.
Steady Red	Module switching to configuration.
Green	Module performing normally.

#### Error States

Solid Red	Module not controlling, and not communicating.
Green/Pulsing Red	Module is controlling properly, but has lost communication with the Master.

### OP1, OP2, OP3, – OUTPUT STATUS LED

The OP1, OP2, and OP3 LEDs are factory configured to indicate the status of the outputs. The LEDs turn on when the output is active.

These LEDs may be remapped to various other module properties.

### ALM – ALARM LED

The Alarm LED is factory configured to indicate the presence of an alarm. Whenever one of the seven alarms is active, the LED turns on.

This LED may be remapped to various other module properties.

### FIRMWARE UPGRADE

The module's firmware is stored in flash memory to prevent software/hardware conflicts, and so that software features may be added in the future.

During a download, Crimson compares its own library of firmware files with those stored in the Master module. If they do not match, Crimson will download the necessary files. The Master then checks to make sure that the I/O modules contain the same firmware. If they contain a different revision, the Master will automatically copy those files into the module's flash memory. During this process, the module LEDs will flash rapidly, starting with the top row, and progressing through the remaining rows until the process is complete.

### CONFIGURATION

Programming is done via Crimson<sup>®</sup> software, a Windows<sup>®</sup> compatible configuration interface. Please see the Crimson manual for more information.

## ORDERING INFORMATION

TYPE	MODEL NO.	DESCRIPTION	PART NUMBER
Master Module	CSMSTR	Modular Controller Master, Multi Comms ports and Ethernet	CSMSTRV2
		Modular Controller Master with multiple protocol converter, data logger, web server with Virtual HMI up to QVGA (320 x 240) size and expansion slot.	CSMSTRSX
		Modular Controller Master with multiple protocol converter, data logger, web server with Virtual HMI up to VGA (640 x 480) size and expansion slot with increased SDRAM	CSMSTRGT
Strain Gage Control Modules	CSSG1 <sup>1</sup>	Single Loop, One SG Input, Relay Outputs, Analog Out	CSSG10RA
		Single Loop, One SG Input, Solid State Outputs, Analog Out	CSSG10SA
		Single Loop, Two SG Inputs, Relay Outputs, Analog Out	CSSG11RA
		Single Loop, Two SG Inputs, Solid State Outputs, Analog Out	CSSG11SA
Communications Cables (10 feet)	CBL	Programming Cable for CS, G3, & Paradigm Series	CBLPROG0
		Communications Cables <sup>1</sup>	CBLxxxx
Software		Crimson <sup>®</sup> Programming Software <sup>2</sup>	SFCRM
		Crimson <sup>®</sup> Programming Software, Manual, and Download Cable	SFCRK
Accessories		Rail Stops (Qty 2)	RSRSTP00
		Replacement Base	CSBASE00
		Replacement Termination Plug	CSTERM00

<sup>1</sup> Visit [www.redlion.net](http://www.redlion.net) for a complete list of PID modules, data acquisition modules, communications drivers and cables.

<sup>2</sup> Free at [www.redlion.net](http://www.redlion.net)

This page intentionally left blank

**Re-Order from**   
**Omegamation™**  
**1-888-55-66342**  
**1-888-55-OMEGA**  
**omegamation.com**

#### LIMITED WARRANTY

The Company warrants the products it manufactures against defects in materials and workmanship for a period limited to two years from the date of shipment, provided the products have been stored, handled, installed, and used under proper conditions. The Company's liability under this limited warranty shall extend only to the repair or replacement of a defective product, at The Company's option. The Company disclaims all liability for any affirmation, promise or representation with respect to the products.

The customer agrees to hold Red Lion Controls harmless from, defend, and indemnify RLC against damages, claims, and expenses arising out of subsequent sales of RLC products or products containing components manufactured by RLC and based upon personal injuries, deaths, property damage, lost profits, and other matters which Buyer, its employees, or sub-contractors are or may be to any extent liable, including without limitation penalties imposed by the Consumer Product Safety Act (P.L. 92-573) and liability imposed upon any person pursuant to the Magnuson-Moss Warranty Act (P.L. 93-637), as now in effect or as amended hereafter.

No warranties expressed or implied are created with respect to The Company's products except those expressly contained herein. The Customer acknowledges the disclaimers and limitations contained herein and relies on no other warranties or affirmations.

Red Lion Controls  
Headquarters  
20 Willow Springs Circle  
York PA 17406  
Tel +1 (717) 767-6511  
Fax +1 (717) 764-0839

Red Lion Controls  
Europe  
Printerweg 10  
NL - 3821 AD Amersfoort  
Tel +31 (0) 334 723 225  
Fax +31 (0) 334 893 793

Red Lion Controls  
India  
54, Vishvas Tenement  
GST Road, New Ranip,  
Ahmedabad-382480 Gujarat, India  
Tel +91 987 954 0503  
Fax +91 79 275 31 350

Red Lion Controls  
China  
Unit 101, XinAn Plaza  
Building 13, No.99 Tianzhou Road  
ShangHai, P.R. China 200223  
Tel +86 21 6113-3688  
Fax +86 21 6113-3683